

**POLITECHNIKA ŚLĄSKA**  
**WYDZIAŁ CHEMICZNY**  
**KATEDRA FIZYKOCHEMI I TECHNOLOGII POLIMERÓW**

**mgr inż. Bartłomiej Kramarczyk**  
**Dyscyplina naukowa: Inżynieria Chemiczna**

## **ROZPRAWA DOKTORSKA**

**Opracowanie nowatorskiej i ekologicznej formuły materiału  
wybuchowego emulsyjnego luzem o zwiększonych parametrach  
detonacyjnych i stabilności chemicznej**

**Development of a novel and ecological formula of a bulk emulsion  
explosive with increased detonation parameters and chemical  
stability**

**Promotor pracy: dr hab. inż. Katarzyna Jaszcz, Profesor Politechniki Śląskiej**  
**Promotor pomocniczy: dr inż. Tomasz Jarosz**

**GLIWICE 2022**

*Dziękuję mojej promotor dr hab. inż. Katarzynie Jaszcz, prof. Pol. Śl. oraz promotorowi pomocniczemu dr inż. Tomaszowi Jaroszowi za wszelką pomoc w realizacji pracy od strony naukowej i cenne uwagi wniesione do opublikowanych artykułów oraz niniejszej rozprawy.*

*Dziękuję Zarządowi NITROERG S.A., za umożliwienie mi realizacji niniejszego projektu, mojej szefowej Elżbiecie Błotny oraz najbliższym współpracownikom za okazaną pomoc i wyrozumiałość podczas prowadzenia prac eksperymentalnych i przygotowywania niniejszej rozprawy. Dziękuję dr inż. Januszowi Kaziemko za opiekę ze strony Przedsiębiorcy.*

*Szczególne podziękowania pragnę złożyć współautorom załączonych w pracy publikacji, a w szczególności dr inż. Piotrowi Mertuszcze z Centrum Badawczo-Rozwojowego KGHM Cuprum oraz Mateuszowi Pytlikowi z Jednostki Oceny Zgodności Głównego Instytutu Górnictwa, za niesamowitą współpracę, zaangażowanie oraz ogromną pomoc w realizacji i prowadzeniu badań.*

*Dziękuję również mojej narzeczonej Magdzie, za wsparcie i motywację.*

## Spis treści

Wykaz skrótów oraz definicje pojęć stosowanych w przewodniku:.....	5
Wykaz publikacji będących podstawą rozprawy doktorskiej .....	6
1. Wstęp .....	8
1.1. Ogólne informacje o materiałach wybuchowych i materiałach wybuchowych emulsyjnych. ....	8
1.2. Uzasadnienie podjęcia problematyki badawczej.....	9
1.3. Problematyka rozwoju MWE i jej praktyczne znaczenie .....	11
1.3.1. Produkcja i rozwój MWE w NITROERG S.A.....	11
1.3.2. Problemy związane ze stosowaniem MWE luzem.....	11
1.3.3. Potrzeby rynkowe modyfikacji i usprawniania dotychczasowych rozwiązań .....	12
2. Cel i zakres pracy.....	14
3. Obecny stan wiedzy w zakresie MWE .....	15
3.1. Parametry opisujące użytkowe cechy MWE.....	15
3.2. Proces uczulania MWE luzem i jego wpływ na ich właściwości energetyczne .....	16
3.3. Wpływ dodatków na właściwości użytkowe MWE i ich stabilność oraz stabilność procesu uczulania .....	16
4. Metodyka badawcza.....	18
5. Przedstawienie i omówienie wyników badań .....	24
5.1. Badania wstępne.....	24
5.2. Badania walidacyjne .....	24
5.3. Laboratoryjne badania parametrów energetycznych.....	26
5.3.1. Badanie składu gazów postrzałowych.....	26
5.3.2. Pomiary prędkości detonacji .....	27
5.3.3. Pomiary ciśnienia fali podmuchowej .....	28
5.3.4. Ocena kruszności metodą Hessa.....	29
5.3.5. Oznaczanie względnej zdolności do wykonania pracy .....	29

5.3.6.	Wnioski z badań laboratoryjnych.....	30
5.4.	Badania użyteczności w warunkach górniczych.....	31
5.4.1.	Wstępne badania wrażliwości na bodźce proste.....	31
5.4.2.	Badania w warunkach użytkowych.....	31
6.	Podsumowanie.....	35
7.	Znaczenie pracy i wpływ jej wyników na rozwój nauki i techniki.....	36
8.	Wdrożeniowy potencjał uzyskanych wyników.....	37
9.	Literatura.....	38

## **Wykaz skrótów oraz definicje pojęć stosowanych w przewodniku:**

ANFO – (ang. *Ammonium Nitrate Fuel Oil*) materiał wybuchowy na bazie azotanu(V) amonu i oleju.

MW – materiał wybuchowy.

MWE – materiał wybuchowy emulsyjny.

MUP – modułowe urządzenie pompujące. System umożliwiający mechaniczny załadunek MWE luzem.

VoD – (ang. *Velocity of Detonation*) prędkość detonacji.

Calizna skalna – nienaruszony pokład złoża.

Fracja urobku – rozkład rozdrobnienia okruchów skalnych po zakończeniu prac strzałowych.

Hot spots – (*gorące punkty*) – zarodniki detonacji w postaci drobnych pęcherzyków gazu bądź mikrosfer szklanych, zawieszane w matrycy emulsji.

Matryca – nieuczulona, wysokoskoncentrowana emulsja typu w/o. Fazę wodną stanowi azotan(V) amonu a faza organiczna składa się z olejów mineralnych i emulgatorów.

Nadgabaryty – bryły skalne posiadające rozmiar większy od założonego na etapie projektowania prac strzałowych.

Stopień uczulenia – stopień i równomierność wypełnienia danej objętości matrycy emulsji gorącymi punktami.

Uczulacz – komponent MWE luzem, który po zmieszaniu z matrycą, zmniejsza jej gęstość i generuje drobne pęcherzyki gazu.

Zdolność urabiająca – efektywność danego MW w kruszeniu calizny skalnej i przemieszczaniu powstałych okruchów skalnych.

## Wykaz publikacji będących podstawą rozprawy doktorskiej

Rozprawę doktorską stanowi cykl sześciu publikacji P1 i E1-E5. Publikacja P1 jest pracą przeglądową, w której zawarto najważniejsze informacje na temat rodzajów MWE, składu, sposobów uczulania, modyfikacji, parametrów detonacyjnych, przeznaczenia i technologii produkcji. Pozostałe publikacje E1-E5 zawierają pełną dokumentację prac badawczych wykonanych w ramach doktoratu wdrożeniowego, wraz z ich wynikami, dyskusją i interpretacją.

### Praca przeglądowa:

[P1] **Kramarczyk B.**, Suda K., Kowalik P., Świątek K., Jaszcz K. Jarosz T.; *Emulsion explosives: A tutorial review of recent progress*, *Materials* **2022**, 15(14), 4952, 140 pkt MEiN, Impact Factor: 3,748, **DOI: 10.3390/ma15144952**

**Wkład własny w publikację 35%:** Opracowanie koncepcji pracy, przegląd literatury, nadzór nad tworzeniem manuskryptu.

### Prace eksperymentalne:

[E1] Mertuszka P., **Kramarczyk B.**; *The Impact of Time on the Detonation Capacity of Bulk Emulsion Explosives based on Emulinit 8L, Propellants, Explosives, Pyrotechnics*, **2018**, Vol. 43, Issue 8, str. 799-804, 70 pkt MEiN, Impact Factor: 2,134, **DOI: 10.1002/prop.201800062**

**Wkład własny w publikację 30%:** Przygotowanie poligonu oraz próbek MW do badań terenowych, udział w badaniach, graficzne przedstawienie wyników pracy, ocena merytoryczna prac.

[E2] **Kramarczyk B.**, Pytlik M., Mertuszka P.; *Effect of aluminium additives on selected detonation parameters of a bulk emulsion explosive*, *High Energy Materials*, **2020**, 12 (2), 99 – 113; 20 pkt MEiN, **DOI: 10.22211/matwys/0197**

**Wkład własny w publikację 40%:** Określenie celów i założeń badawczych, przeprowadzenie przeglądu literaturowego, opracowanie koncepcji pracy, opracowanie harmonogramu i udział w badaniach polowych, analiza wyników badań oraz sformułowanie wniosków (wraz ze współautorem), przygotowanie manuskryptu artykułu od strony merytorycznej i graficznej.

**[E3] Kramarczyk B.**, Mertuszka P.; *Study of the Influence of Sensitizer Content on the Density of a Bulk Emulsion Explosive Used in Underground Operations*, Cent. Eur. J. Energ. Mater. **2021**, 18(4): 429-447; 70 pkt MEiN, Impact Factor: 1,104, **DOI 10.22211/cejem/144498**

**Wkład własny w publikację 60%:** Przygotowanie próbek MW do badań laboratoryjnych oraz udział w badaniach, nadzór nad pracami laboratoryjnymi, interpretacja wyników (ze współautorem), opracowanie podstaw teoretycznych oraz ocena merytoryczna prac.

**[E4] Kramarczyk B.**, Pytlik M., Mertuszka P., Jaszcz K., Jarosz T.; *Novel Sensitizing Agent Formulation for Bulk Emulsion Explosives with Improved Energetic Parameters*, Materials **2022**, 15, 900; 140 pkt MEiN, Impact Factor: 3,623, **DOI: 10.3390/ma15030900**

**Wkład własny w publikację 35%:** Sformułowanie celów i założeń badawczych, dokonanie przeglądu literaturowego (razem z zespołem), współudział w opracowaniu koncepcji pracy, udział w badaniach polowych, analiza wyników i sformułowanie wniosków (razem z zespołem), przygotowanie wstępnej wersji manuskryptu.

**[E5] Mertuszka P.**, **Kramarczyk B.**, Pytlik M., Szumny M., Jarosz T., Jaszcz K.; *Implementation and Verification of Effectiveness of Bulk Emulsion Explosive With Improved Energetic Parameters in an Underground Mine Environment*, Energies **2022**, vol. 15 (17), s. 6424; 140 pkt MEiN, Impact Factor; 3,252, **DOI: 10.3390/en15176424**

**Wkład własny w publikację 25%:** Sformułowanie celów i założeń badawczych, udział w opracowaniu koncepcji pracy, przeprowadzenie badań, analiza wyników i sformułowanie wniosków (razem z zespołem) oraz przygotowanie wstępnej wersji manuskryptu.

## 1. Wstęp

### 1.1. Ogólne informacje o materiałach wybuchowych i materiałach wybuchowych emulsyjnych.

Materiały wybuchowe emulsyjne (MWE) stanowią najnowszą grupę materiałów wybuchowych (MW) przeznaczonych do użytku cywilnego. Zostały opracowane ponad 50 lat temu [1], a technologia ich produkcji jest stale rozwijana [2, 3]. Obecnie są powszechnie stosowane do wydobycia skał, zarówno w kopalniach podziemnych, jak i odkrywkowych, a także w budowie tuneli, rozbiórkach i innych obszarach inżynierii lądowej [4, 5]. MWE wytwarzane są w dwóch podstawowych grupach produktowych, tzn. jako MWE nabożowane i MWE luzem. MWE nabożowane są gotową formą użytkową, mającą postać foliowych nabożów o określonej masie, średnicy i długości. MWE „luzem” ma postać dwóch niewybuchowych składników. Właściwy materiał wybuchowy powstaje dopiero po ich zmieszaniu i upływie czasu.

MWE stanowią nowoczesną alternatywę dla klasycznych MW przeznaczonych do użytku cywilnego (np. MW amonowo-saletrzone, dynamity). MWE nie zawierają składników wybuchowych, przez co ich produkcja jest znacznie bezpieczniejsza niż klasycznych MW. W przeciwieństwie do MW nitroestrowych (dynamitów), MWE nie zawierają substancji toksycznych lub uciążliwych dla personelu czy to podczas produkcji czy podczas użytkowania [6]. MWE zawierają stosunkowo dużą ilość wody, co sprawia, że podczas transportu, przechowywania czy użytkowania istnieje mniejsze ryzyko ich przypadkowego wybuchu niż ma to miejsce w przypadku klasycznych MW, a w szczególności w przypadku MW nitroestrowych. W związku z wysokim stopniem przereagowania podczas detonacji, skład gazów postrzałowych jest także bardziej korzystny (mniejsza emisja tlenków azotu z jednostkowej masy), niż w przypadku tradycyjnych MW [7]. Wykazują zdecydowanie bardziej przyjazne środowisku naturalnemu właściwości w porównaniu do MW zawierających w składzie estry kwasu azotowego czy nitrozwiązki, które mogą przenikać do gleby czy wód gruntowych [8].

Podstawowym składnikiem MWE jest emulsja typu woda w oleju w/o. Fazę wodną stanowi nasycony roztwór azotanu(V) amonu, zawierający również substancje pomocnicze. Fazę organiczną stanowi olej i emulgator. Emulsja, tzw. „matryca” stanowi układ teoretycznie zdolny do wybuchu, lecz z uwagi na praktyczną niewrażliwość na bodźce inicjujące,



traktowana jest jako utleniacz w klasyfikacji transportowej 5.1 międzynarodowej konwencji dotyczącej drogowego przewozu towarów i ładunków niebezpiecznych [9].

Matryca MWE musi zostać poddana procesowi uczulania, aby stać się właściwym materiałem wybuchowym. Uczulanie polega na wprowadzeniu niejednorodności, w postaci drobnych wtrąceń pęcherzyków powietrza, bądź innego gazu w całej objętości emulsji. Podczas przejścia fali detonacyjnej, wytworzone pęcherzyki gazu ulegają sprężeniu adiabatycznemu, w wyniku którego rozgrzewają się do bardzo wysokich temperatur, które indukują gwałtowny rozkład azotanu(V) amonu z wydzieleniem tlenu. Zawarte w emulsji paliwa pochodzące z fazy organicznej, ulegają gwałtownemu spalaniu z wydzieleniem znacznych ilości ciepła oraz gazowych produktów spalania, powodując podtrzymanie procesu detonacji. Niejednorodności w postaci pęcherzyków gazu znacząco zmniejszają gęstość ośrodka, co ułatwia rozchodzenie się i propagację fali detonującej [10].

Znane i obecnie stosowane są dwie metody uczulania: fizyczna i chemiczna [11]. Fizyczna polega na dodatku tzw. mikrosfer szklanych o bardzo małej gęstości rzędu  $0,1 - 0,2\text{g/cm}^3$ . Realizowane jest to na etapie mieszania matrycy emulsji ze składnikami modyfikującymi. Ta forma uczulania najczęściej wykorzystywana jest do MWE nabojoyanych czyli gotowej formy użytkowej materiału wybuchowego. Metoda chemiczna stosowana jest głównie w przypadku MWE luzem. Polega na reakcji uczulacza z fazą utleniaczy z matrycy, w wyniku której wydzielą się gaz w postaci drobnych pęcherzyków wypełniających całą objętość matrycy emulsji [P1].

## **1.2. Uzasadnienie podjęcia problematyki badawczej**

Pierwsze przemysłowe zastosowanie MWE luzem w podziemnych polskich kopalniach miedzi należących do KGHM Polska Miedź przeprowadzono w 1997 roku w kopalni „Rudna”. W 2004r. już prawie 10% materiałów wybuchowych użytych w kopalni „Rudna” stanowiły MWE luzem [12]. W kolejnych latach wykorzystanie materiałów wybuchowych luzem stale wzrastało. W ostatnim czasie ponad 80% używanych w KGHM materiałów wybuchowych stanowią MWE luzem. Co roku notowane jest coraz większe zużycie MWE. W latach 2020/2021 wzrosło ono o ok. 10% względem lat 2019/2020.

Rosnący udział MWE luzem w rynku MW przeznaczonych do użytku cywilnego jest efektem szeregu zalet (mniejsza wrażliwość na bodźce proste, bezpieczniejsze dla środowiska i nietoksyczne składniki) tych materiałów na tle konkurencyjnych rozwiązań opartych o klasyczne MW. Najważniejszą zaletą MWE jest podwyższone bezpieczeństwo podczas

transportu i użytkowania tego typu materiałów wybuchowych. MWE luzem są produkowane i dostarczane do miejsca przeznaczenia w postaci dwóch niewybuchowych składników. Do załadunku otworów strzałowych używa się specjalnych modułowych układów pompująco-załadowczych MUP (Rysunek 1), zabudowanych na samojezdnych wozach strzałowych SWS. Oprogramowanie sterujące wraz z odpowiednio dobranymi pompami i mieszalnikiem statycznym zapewnia dokładne, zgodne z recepturą wymieszanie matrycy emulsji oraz uczulacza [13]. Mieszanina włączana jest do otworów strzałowych za pomocą węża załadowczego. Dopiero po upływie określonego czasu, pod wpływem reakcji chemicznych, staje się materiałem wybuchowym wrażliwym na bodźce inicjujące. Dzięki temu nie ma możliwości kontaktu personelu z MW (przeciwdziałanie kradzieżom oraz brak narażenia na potencjalnie szkodliwe substancje).

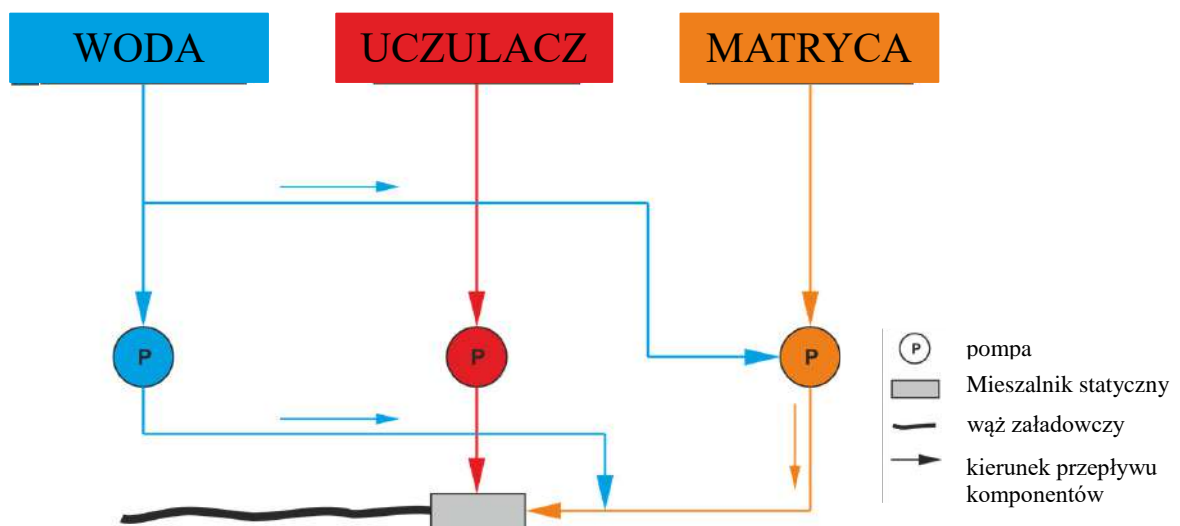

**Rysunek 1.** Wygląd zewnętrzny oraz schemat ideowy MUP.

Oprócz bezpieczeństwa należy również wspomnieć o usprawnieniu robót strzałowych. Tradycyjny załadunek jakichkolwiek materiałów wybuchowych w postaci naboju jest czasochłonny i uciążliwy, ze względu na warunki panujące w kopalni. Załadunek

mechaniczny pozwala na znaczne skrócenie robót strzałowych, dzięki czemu górnicy krócej przebywają w ciężkich i niebezpiecznych warunkach, a postęp robót jest dużo szybszy, co bezpośrednio wpływa na aspekt ekonomiczny wydobywania.

### **1.3. Problematyka rozwoju MWE i jej praktyczne znaczenie**

#### **1.3.1. Produkcja i rozwój MWE w NITROERG S.A**

Początek produkcji MWE w NITROERG S.A. w Bieruniu to rok 1997. Pierwsze lata produkcji opierały się na dostarczonych wraz z instalacją formułach na włoskiej licencji Dott. Mariano Pravisani & C. srl i produkowane były wyłącznie asortymenty w formie naboju. Dziesięć lat później zostały opracowane w zakładzie formuły MWE luzem oraz MWE bezpieczne wobec metanu i pyłu węglowego. Materiały te były przedmiotem badań, które prowadziłem w ramach pracy dyplomowej w ramach studiów podyplomowych Technologia Materiałów Wybuchowych na Politechnice Śląskiej w Gliwicach. Badania te były początkiem mojej aktywności naukowej, a opracowane wówczas formuły MWE niezmiennie produkowane są przez NITROERG S.A. do dnia dzisiejszego.

#### **1.3.2. Problemy związane ze stosowaniem MWE luzem**

MWE luzem, choć znacząco ułatwiają prace strzałowe i są znacznie bezpieczniejsze w stosowaniu niż klasyczne MW, mają również wady, a największą z nich są niższe niż w przypadku MWE naboju i klasycznych MW parametry detonacyjne (Tabela 1).

**Tabela 1.** Porównanie średnich wartości prędkości detonacji dla MWE luzem, naboju i dynamitów [14].

<b>Materiał wybuchowy</b>	<b>Prędkość detonacji [m/s]</b>
MWE luzem	3800
MWE naboju	4700
Dynamity	5500

MWE luzem, z uwagi na zachodzący proces uczulania, charakteryzują się również zmiennością parametrów strzałowych w zależności od interwału czasowego pomiędzy załadunkiem MWE do otworu strzałowego, a jego zainicjowaniem. Interwał ten jest ściśle uzależniony od procedur obowiązujących w danym miejscu użytkowania, przez co utrudniona jest precyzyjna kontrola uzyskiwanych frakcji urobku [15]. Odpowiednie rozdrobnienie jest czynnikiem wpływającym na bezpośrednie koszty wydobywania, gdyż np. w przypadku nadgabarytów należy prowadzić dodatkowe rozdrabnianie urobku.

Przemysł stara się odpowiedzieć na zapotrzebowanie na MWE luzem o zwiększonej energetyce i stabilności parametrów, ale jak dotąd nie udało się tego zrealizować w sposób bezpieczny i efektywny [16]. Najczęściej spotykanym sposobem poprawy parametrów strzałowych MWE jest dodatek aluminium, ale takie rozwiązanie może komplikować produkcję, znacząco zwiększać koszty oraz mieć bezpośredni wpływ na trwałość i bezpieczeństwo stosowania tak zmodyfikowanych MWE [E2]. Istnieją także inne alternatywne metody modyfikacji MWE (np. dodatek prochów nitrocelulozowych [17]), mające posłużyć podwyższeniu parametrów ich detonacji, jednakże nie są one pozbawione istotnych wad, zarówno podczas produkcji jak i użytkowania. Problematyka ta została szerzej opisana w publikacji [P1] oraz w punkcie 3.3.

### **1.3.3. Potrzeby rynkowe modyfikacji i usprawniania dotychczasowych rozwiązań**

Największa część produkowanych przez NITROERG S.A. asortymentów to MWE luzem, z czego aż ponad 80% zużywane jest w podziemnych kopalniach KGHM. Postęp wydobywania wymusza coraz głębszą eksploatację, z czego wynika zmienność warunków geologicznych, w których prowadzone są prace strzałowe. Zmienia się przede wszystkim temperatura panująca w przodkach wydobywczych – nierzadko spotykane są temperatury skał rzędu nawet do 40–50°C. Z powodu znaczącego wpływu temperatury na szybkość procesu uczulania, a w szczególności na szybkość reakcji, w wyniku których powstają pęcherzyki gazu, MWE luzem są bardzo wrażliwe na zmiany temperatur. Na rys. 2 przedstawiono wpływ temperatury na zmiany gęstości wywołane procesem uczulania dla stosowanego obecnie MWE luzem, Emulinitu 8L. Obserwowane różnice w zmianach gęstości, pokazują że stosowana receptura wraz ze wzrostem temperatury może wykazywać obniżone parametry detonacyjne z powodu zbyt dalekiego postępu reakcji uczulania.

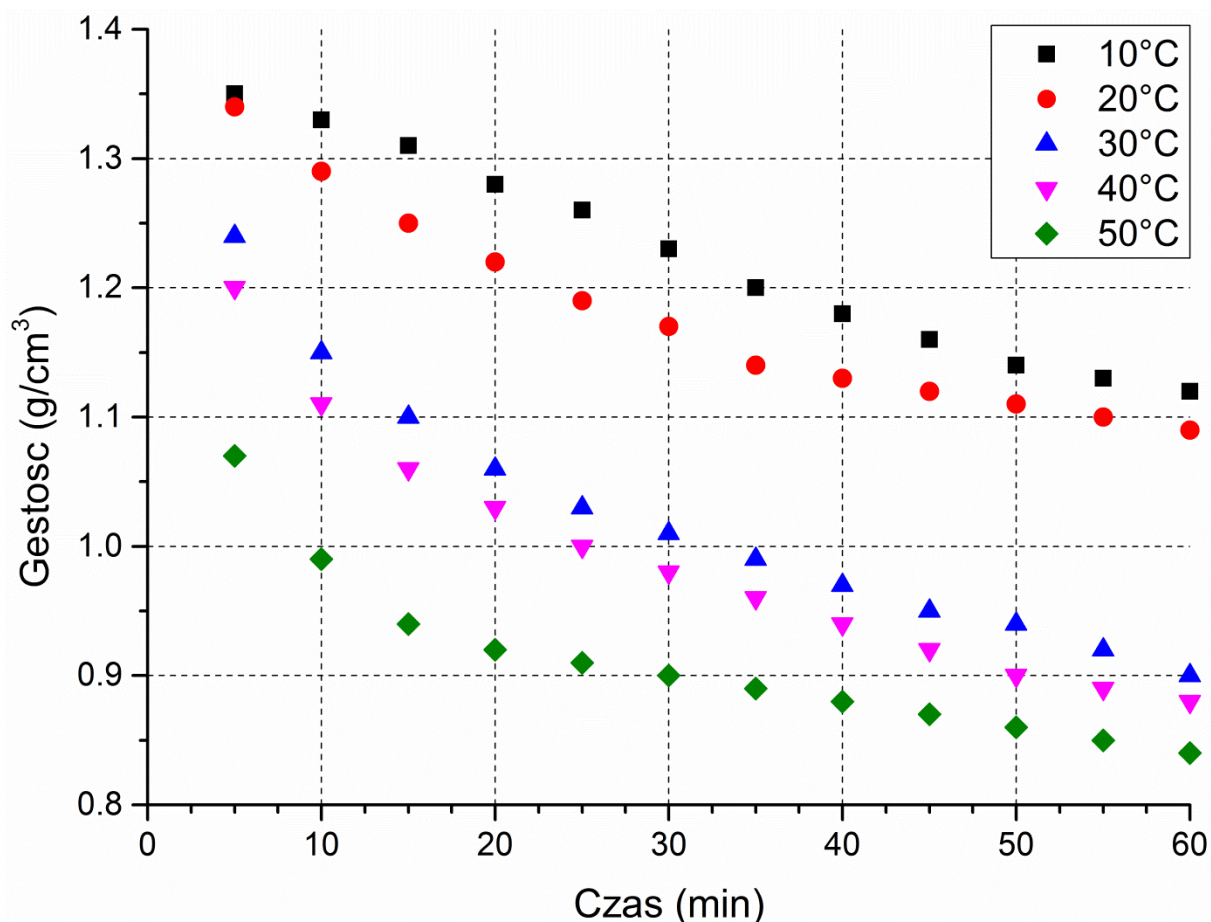

**Rysunek 2.** Wpływ temperatury na zmiany gęstości rynkowo dostępnego MWE luzem (Emulinit 8L) wywołane postępowaniem procesu uczulania.

Innymi obszarami zastosowań MWE luzem są prace strzałowe prowadzone w kopalniach odkrywkowych oraz przy budowie tuneli [18]. W przypadku tych zastosowań, MWE musi zachować niezmienną wartość parametrów w szerokim zakresie temperatur, ponieważ nawet w jednej kopalni, temperatury mogą znacząco się różnić w zależności od rejonu wydobycia. Wysoka twardość i zwięzłość skał wymaga również, aby stosowany MW cechował się możliwie wysokimi parametrami detonacyjnymi. Obecnie produkowane MWE luzem charakteryzują się niższą zdolnością urabiającą w porównaniu z MWE nabożowanymi czy MW nitroestrowymi (dynamitami). Wynika stąd bezpośrednia potrzeba opracowywania nowych formuł o poprawionych parametrach strzałowych.

## 2. Cel i zakres pracy

Celem pracy było opracowanie nowej receptury MWE luzem o poprawionych parametrach detonacyjnych i lepszej stabilności chemicznej względem obecnie produkowanego w NITROERG S.A. Emulinitu 8L.

Zasadność opracowania nowej formuły MWE, będącej przedmiotem pracy, podąża za dwoma aktualnie podstawowymi wyzwaniami rynku, tj.:

- Optymalizacja parametrów prac strzałowych zwłaszcza przy eksploatacji twardych skał i zmiennych temperatur calizny skalnej w której prowadzone są prace strzałowe,
- Obniżenie emisji gazów postrzałowych, co jest obecnie podstawowym kierunkiem zmian legislacyjnych w UE dotyczących stosowania materiałów wybuchowych [19].

Zakres prac prowadzących do osiągnięcia założonego celu obejmował następujące zadania badawcze:

- Zbadanie standardowej (produkowanej w skali przemysłowej) formułacji MWE luzem pod kątem zmian parametrów strzałowych w czasie [E1],
- Określenie możliwości podwyższenia parametrów strzałowych standardowej formułacji MWE luzem poprzez dotowanie jej aluminium granulowanym [E2],
- Zbadanie kinetyki uczulania MWE zarówno w laboratorium jak i w docelowych warunkach użytkowania, w celu rozpoznania możliwości wpłynięcia na te procesy, tak aby dopasować ich przebieg do oczekiwań użytkownika [E3],
- Opracowanie składu nowego komponentu uczulającego, dzięki któremu otrzymywany MWE będzie uczulać się szybko i stabilnie, posiadać wyższe od obecnej formuły parametry detonacyjne oraz pozwoli na obniżenie zawartości toksycznych gazów postrzałowych. Zbadanie w warunkach laboratoryjnych nowej formuły MWE luzem [E4],
- Ocena możliwości aplikacji oraz zbadanie parametrów użytkowych w nowej formuły MWE luzem w docelowych warunkach użytkowania [E5].

### 3. Obecny stan wiedzy w zakresie MWE

#### 3.1. Parametry opisujące użytkowe cechy MWE

Parametrem najczęściej używanym do opisu materiałów wybuchowych jest prędkość detonacji (VoD). Jest to maksymalna prędkość propagacji, z jaką fala detonacyjna może rozchodzić się w danym materiale wysokoenergetycznym. Wartość VoD jest funkcją zarówno właściwości fizykochemicznych materiału wysokoenergetycznego (np. skład chemiczny, gęstość), jak i cech badanego ładunku (np. średnica ładunku) [20].

MWE charakteryzują się wysoce rozwiniętą powierzchnią kontaktu pomiędzy utleniaczem a paliwem, przekraczającą limit dla mieszanin czy zawiesin [P1]. Ta właściwość pozwala na uzyskanie doskonałych parametrów detonacyjnych [21], w przeciwieństwie do tradycyjnych MW w postaci mieszanin wykorzystujących azotan(V) amonu (np. ANFO). Różnice widać głównie w prędkości detonacji. Podczas gdy tradycyjne materiały typu ANFO zwykle cechują się wartościami VoD nieprzekraczającymi 3000 m/s, MWE zazwyczaj osiągają wartości prędkości detonacji przekraczające 4500 m/s [22].

W przypadku MWE nabojujących prędkość detonacji nie zmienia się w czasie, ponieważ forma fizycznego uczulania mikrosferami jest bardzo stabilna.

W przeciwieństwie do MWE uczulanych fizycznie (za pomocą mikrosfer szklanych bądź tworzywowych) [23], zastosowanie chemicznego uczulania w MWE luzem zapewnia niższą stabilność parametrów, ponieważ reakcji leżącej u podstaw uczulenia nie można zatrzymać w dowolnym momencie. W konsekwencji, w przypadku MWE luzem czas, jaki upłynął między uczuleniem matrycy załadowanej do odwiertu a zainicjowaniem ładunku, który jest często określany jako „czas uśpienia”, powoduje zmiany w gęstości i prędkości detonacji [E1]. Ponadto wielkość i tempo zmian właściwości MWE w czasie zależy od czynników środowiskowych, przede wszystkim temperatury.

Gęstość w przypadku MWE ma nieco odmienny wpływ na VoD niż w przypadku klasycznych MW, gdzie wyższa gęstość pozwala na uzyskanie większych wartości prędkości detonacji. W przypadku MWE gęstość jest ściśle powiązana ze stopniem uczulenia.

Krzywa opisująca zależność prędkości detonacji od gęstości MWE ma charakterystyczny kształt dzwonu: najpierw wraz ze wzrostem gęstości VoD rośnie liniowo, następnie powoli maleje, przy określonej gęstości MWE prędkość detonacji osiąga największą wartość, a wraz z dalszym wzrostem gęstości VoD maleje. Wreszcie, gdy gęstość MWE osiągnie określoną

wartość graniczną, zdolność MWE do detonacji zanika. Jednocześnie wraz ze wzrostem średnicy ładunku MWE wzrasta wartość gęstości, przy której VoD osiąga swoją maksymalną wartość. Wartość maksymalnej prędkości detonacji również wzrasta (w porównaniu do najwyższej VoD dla mniejszej średnicy ładunku).

### **3.2. Proces uczulania MWE luzem i jego wpływ na ich właściwości energetyczne**

Uczulanie MWE polega na reakcji azotanu(III) sodu znajdującego się w uczulaczu z azotanem(V) amonu, będącym głównym składnikiem matrycy emulsji [E3]. Na docelowe parametry strzałowe największy wpływ wywiera stopień uczulenia i końcowa gęstość. Czynnikiem decydującym o powyższych aspektach jest stopień wymieszania ze sobą komponentów (matryca MWE oraz uczulacz) a tym samym równomierne rozmieszczenie w całej masie pęcherzyków gazu.

W warunkach laboratoryjnych, z uwagi na pracę w reżimie okresowym i brak istotnych ograniczeń dotyczących np. czasu mieszania, możliwe jest osiągnięcie bardzo wysokiego stopnia wymieszania składników MWE.

W warunkach użytkowych, prace z MWE luzem oparte są o wykorzystanie układów przepływowych, przez które przetłaczane są znaczne strumienie masowe składników, a mieszanie, z uwagi na ograniczenia techniczne, realizowane jest za pomocą mieszalników statycznych, może dochodzić do fluktuacji i zaburzeń składu MWE, co bezpośrednio przekłada się na parametry tych MW. Podczas wytwarzania MWE in-situ należy więc zwracać szczególną uwagę na stan urządzeń pompujących i mieszających oraz stale kontrolować jakość uzyskiwanego materiału wybuchowego poprzez wykonywanie pomiarów gęstości [E3].

### **3.3. Wpływ dodatków na właściwości użytkowe MWE i ich stabilność oraz stabilność procesu uczulania**

MWE składają się głównie z nasyconego wodnego roztworu azotanu(V) amonu zemulgowanego z olejami mineralnymi. W takim układzie nie ma dodatków mających właściwości wybuchowe, dzięki czemu produkcja MWE jest stosunkowo bezpieczna [P1]. Możliwe jest wytwarzanie MWE o zwiększonej energetyce, lecz istniejące rozwiązania wymuszają ingerencję w roztwory utleniaczy, co może stwarzać dodatkowe zagrożenia na etapie produkcji, z uwagi na przetwarzanie gorących i stężonych roztworów azotanu(V)



amonu. Znane są przypadki niekontrolowanego rozkładu takich roztworów prowadzące nawet do wybuchu [24].

Spotykane są również rozwiązania w postaci dodatku granulowanego aluminium do gotowej emulsji, ale z uwagi na technologię dozowania, wymuszone jest stosowanie aluminium gruboziarnistego, które, co prawda, podnosi temperaturę wybuchu, ale spowalnia przemianę wybuchową, a to z kolei w rejonach twardej calizny skalnej daje gorsze efekty urabiania [E2].

Największym jednak problemem w przypadku MWE luzem, jest wpływ jakichkolwiek dodatków do matrycy emulsji na jej trwałość. Przyczynia się do tego konieczność często kilkukrotnego przepompowania matrycy na drodze od producenta do miejsca użytkowania. Matryca, jako wysokoskoncentrowana emulsja typu woda w oleju już w stanie czystym jest układem niestabilnym [25], wrażliwym na czynniki zewnętrzne (zmienne temperatury czy siły ścinające), dodatki w postaci stałej znacznie przyspieszają procesy krystalizacji, a tym samym niszczenia struktury emulsji. Pogorszeniu ulegają parametry detonacyjne, a w skrajnych przypadkach może nastąpić zanik zdolności do detonacji – czyli efekt odwrotny do zamierzonego.

Biorąc pod uwagę powyższe aspekty, zaproponowane w niniejszej pracy rozwiązanie nie ingeruje bezpośrednio w matrycę emulsji, a opiera się na zmianie składu komponentu uczulającego. Tylko taki sposób gwarantował zachowanie bezpieczeństwa podczas produkcji, transportu oraz użytkowania MWE luzem i nie wpływał na trwałość matrycy.

#### 4. Metodyka badawcza

**Gęstość i kinetyka uczulania.** Naczynie o znanej objętości ( $115 \text{ cm}^3$ ) napełniano zmieszany w odpowiednich proporcjach komponentami, starając się aby nie powstawały kawerny. Podczas uczulania mieszanina zwiększa swoją objętość i nadmiar był ścinany za pomocą liniału do krawędzi naczynia (Rysunek 3). Całość była ważona w określonych odstępach czasu i z ilorazu masy i objętości wyliczana była gęstość. Postęp i szybkość procesu uczulania badano na podstawie zmian gęstości MWE w funkcji czasu, a uzyskane wartości nanoszono na wykres. Szczegółowa procedura badania została opisana w publikacji [E3].

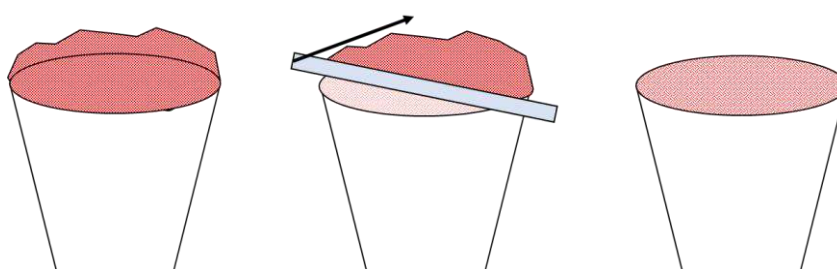

**Rysunek 3.** Schemat oznaczania gęstości MWE luzem.

**Prędkość detonacji** badano metodą ciągłą w oparciu o zmianę rezystancji elektrycznej sondy zwarciowej połączonej z miernikiem MicroTrap (MREL, Kingston, ON, Kanada) [26]. Sondy umieszczane były osiowo w próbce MW z przeciwległego końca ładunku względem punktu inicjowania (Rysunek 4). Fala detonacyjna przebiegająca wzdłuż kolumny ładunku zgniata koncentryczny układ sondy powodując zwarcie. Szybkość zwierania poszczególnych warstw przewodnika koncentrycznego a tym samym zmian oporu elektrycznego, jest równa prędkości fali detonacyjnej, co zostaje zarejestrowane przez miernik w formie wykresu przebiegu fali detonacyjnej wzdłuż całego ładunku. Z wykresu można odczytać z dowolnego punktu odcinkową wartość prędkości detonacji, a także można uśrednić wynik dla całego ładunku. Szczegółowa procedura badania została opisana w publikacjach [E1] i [E4].

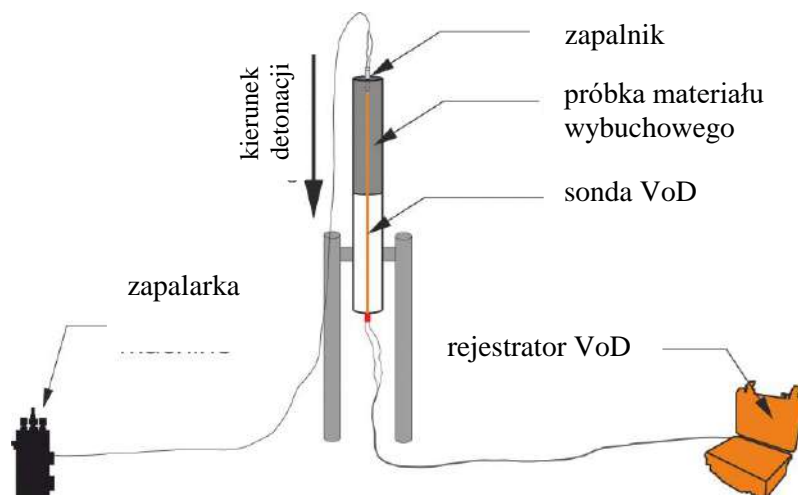

**Rysunek 4.** Schemat układu pomiarowego prędkości detonacji metodą ciągłą [E4].

**Pomiar fali ciśnieniowej** przeprowadzono za pomocą piezoelektrycznych czujników ciśnienia typu 137B23B firmy PCB PIEZOTRONICS o czasie narastania  $\leq 6,5 \mu s$  i zakresie pomiarowym wynoszącym 345 kPa, umieszczonych 1m nad ziemią i w odległościach odpowiednio 2m i 2,5m od badanego ładunku MW (Rysunek 5). Dane rejestrowano przy użyciu wzmacniacza DEWESoft SIRIUS o częstotliwości próbkowania 1MHz sprzężonego z komputerem. Szczegółowa procedura badania została opisana w publikacjach [E2] i [E4].

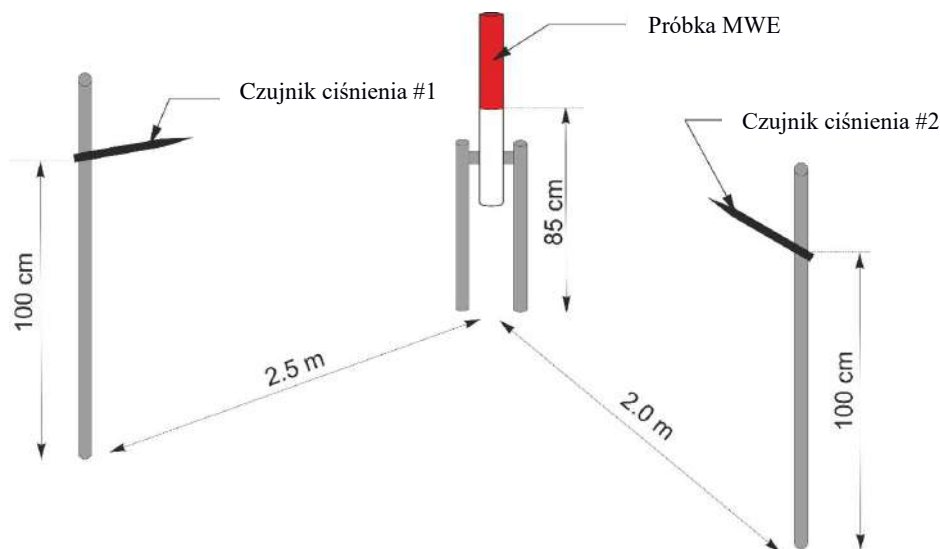

**Rysunek 5.** Schemat stanowiska do pomiaru fali i impulsu ciśnienia detonacji [E4].

**Badanie składu gazów postrzałowych.** Badania wykonano w warunkach laboratoryjnych zgodnie z normą PN-EN 13631-16:2006. Do określania ilości toksycznych tlenków w gazach postrzałowych zastosowano analizatory do pomiaru ciągłego: chemiluminescencyjny (TOPAZE 32M dla tlenków azotu) oraz absorpcyjny promieniowania

w podczerwieni (MIR 25 dla tlenków węgla). Badany materiał ok. 500g umieszczano w szklanych rurach zakończonych z jednej strony przybitką z gliny. Ładunki w takiej postaci detonowane były w specjalnej komorze o objętości 15m<sup>3</sup> (Rysunek 6). Po detonacji gazy z komory, przepompowywane były przez ww. analizatory. Szczegółowa procedura badania została opisana w publikacji [E4].

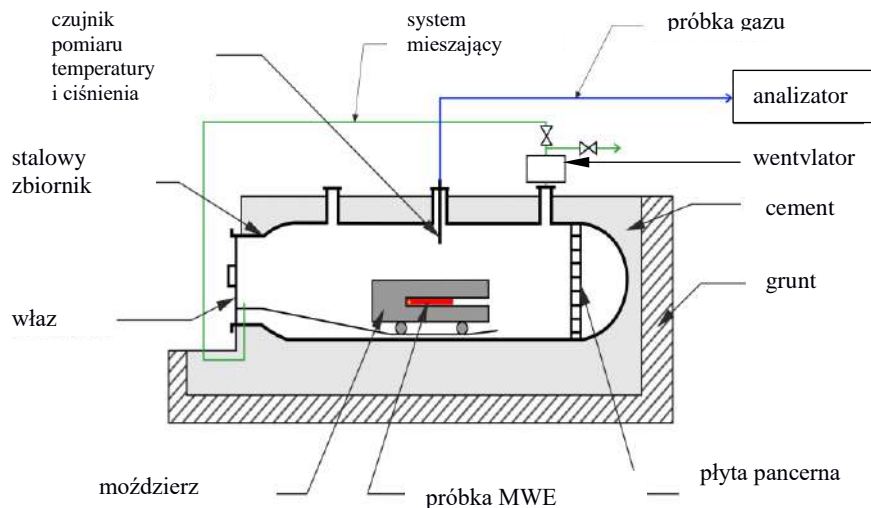

**Rysunek 6.** Schemat stanowiska badawczego gazów postrzałowych [7][E4].

**Oznaczanie względnej zdolności do wykonania pracy** wykonano zgodnie z normą PN-C-86035:2022-04. Wykorzystane zostało znormalizowane stanowisko wahała balistycznego, którego część ruchomą stanowi moździerz w którym umieszcza się próbkę 10g badanego MW (Rysunek 7). Detonacja próbki powoduje wychylenie się ramienia, co zostaje zarejestrowane na skali wycechowanej w stopniach. Jako materiał odniesienia zastosowany był 1,3,5-trinitro-1,3,5-triazacykloheksan (RDX). Szczegółowa procedura badania została opisana w publikacji [E4].



**Rysunek 7.** Wygląd stanowiska do oznaczania względnej zdolności wykonania pracy.

Ocenę kruszności wykonano metodą Hessa na podstawie normy PN-C-86033:2000. Metoda polega na zdetonowaniu próbki 50g MW na walcu ołowianym o wysokości 60mm i średnicy 40mm (Rysunek 8). Po zdetonowaniu badanego materiału mierzy się wielkość odkształcenia walca. Wartość zgniotu  $\Delta H$  w mm jest miarą kruszności. Im bardziej walec ulegnie zgnieceniu tym większa jest kruszność badanego MW. Z uwagi na wielkość i średnicę próbki metoda ta w przypadku MWE daje powtarzalne wyniki i może być z powodzeniem stosowana w celu porównania kruszności tego typu MW. Szczegółowa procedura badania została opisana w publikacji [E4].

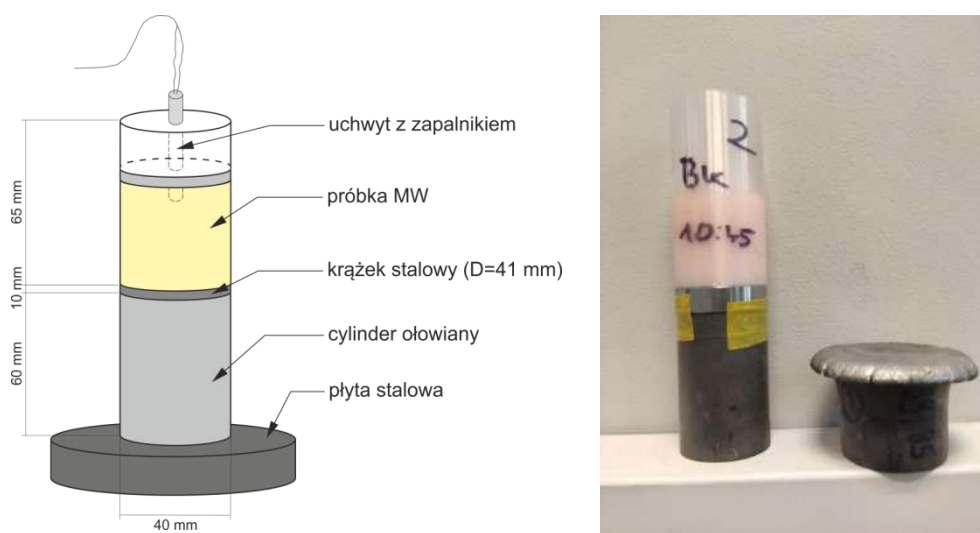

**Rysunek 8.** Schemat układu do badania kruszności metodą Hessa [E4]. Z prawej strony widoczny zgniot walca ołowianego na skutek detonacji próbki.

**Oznaczenie zdolności wykonania pracy w bloku ołowianym** wykonano metodą Trauzla wg normy PN-C-86037:2000. W cylindrycznym walcu ołowianym o średnicy 200mm i wysokości 200mm z wydrążonym otworem o średnicy 25mm (Rysunek 9), umieszcza się próbkę 10g badanego MW. Pod wpływem detonacji, walec ołowiany ulega rozdęciu. Miarą zdolności wykonania pracy jest zmiana objętości spowodowana rozdęciem. Jako materiał odniesienia zastosowany został 2,4,6-trinitrofenol. Szczegółowa procedura badania została opisana w publikacji [E2].



**Rysunek 9.** Przekrój bloku ołowianego przed detonacją (z lewej) i po detonacji (z prawej) [E2].

**Badanie struktury emulsji oraz uczulonego MWE** przeprowadzono pod mikroskopem ZEISS Primotech przy powiększeniu 10x w świetle spolaryzowanym. Szczegółowa procedura badania została opisana w publikacji [E4].

**Badanie wrażliwości na tarcie** wykonano wg normy PN-EN 13631-3:2005 na aparacie tarciovym Petersa (Rysunek 10). Szczegółowa procedura badania została opisana w publikacji [E5].

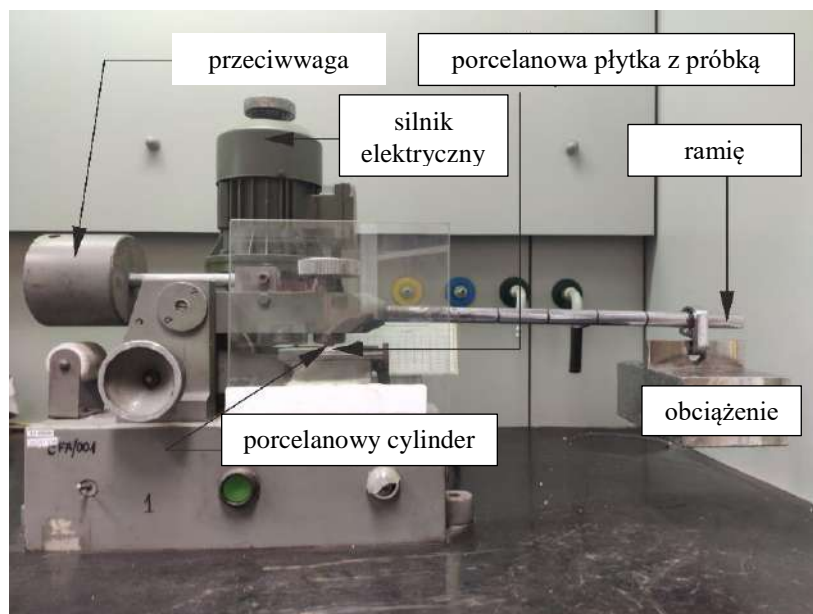

**Rysunek 10.** Aparat do badania wrażliwości MW na tarcie.

**Badanie wrażliwości na uderzenie** wykonano wg normy PN-EN 13631-4:2004 na kafarze BAM (Rysunek 11). Szczegółowa procedura badania została opisana w publikacji [E5].

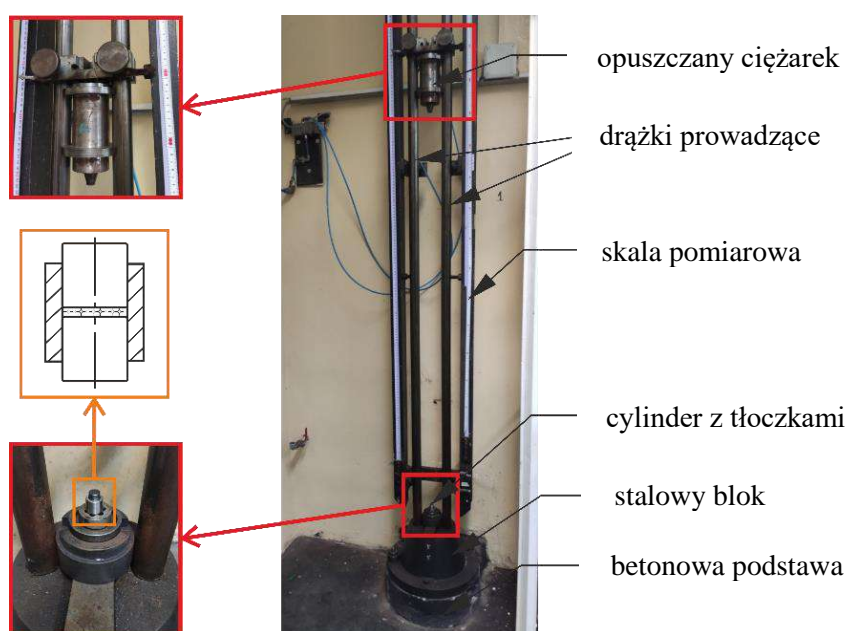

**Rysunek 11.** Kafar do badania wrażliwości MW na uderzenie.

## **5. Przedstawienie i omówienie wyników badań**

### **5.1. Badania wstępne**

W pierwszym etapie badań, prowadzonych w ramach pracy doktorskiej, było dokładne rozpoznanie charakterystyki uczulania oraz wpływu czasu uczulania na prędkość detonacji dla standardowo produkowanego przez NITROERG S.A. Emulinitu 8L. Produkt ten składa się z dwóch komponentów: matrycy (bazującej na azotanie(V) amonu, azotanie wapnia, wodzie, oleju i emulgatorze) i uczulacza, który jest rozcieńczonym wodnym roztworem azotanu(III) sodu.

Zbadano dokładnie kinetykę uczulania w zależności od ilości uczulacza dla standardowej formuły Emulinitu 8L zarówno w warunkach laboratoryjnych jak i użytkowych w KGHM [E3]. Bardzo ważnym aspektem użytkowania MWE luzem, jest ich pewne, odpowiednio szybkie i stabilne uczulanie po zmieszaniu matrycy oraz uczulacza. Prawidłowy proces uczulania jest kluczowy dla uzyskania żądanych i powtarzalnych parametrów strzałowych.

W skali laboratoryjnej, proces uczulania zależy jest efektywnie tylko od jakości komponentów oraz warunków zewnętrznych. Przejście do badań MWE w większej skali wymaga uwzględnienia również istniejących ograniczeń technicznych (np. sprawność modułowych urządzeń pompujących) i ich wpływu na proces uczulania. Reakcje zachodzące podczas procesu uczulania powinny możliwie szybko wygasać tak, aby gęstość nie zmieniała się po określonym czasie. Zmiana gęstości i stopnia uczulenia wpływa na wrażliwość do inicjacji oraz na parametry termodynamiczne wytwarzanego MWE [E1].

W obu przypadkach zauważono, że nawet niewielkie zmiany w dozowaniu składników mają istotny wpływ na wartość gęstości badanego MWE luzem. Dodatkowo, w przypadku użycia standardowego komponentu uczulającego, reakcja uczulania biegnie powoli i nie jest możliwe kontrolowanie, aby zatrzymać jej przebieg po uzyskaniu docelowej gęstości. Powyższe aspekty mogą doprowadzać do obniżania parametrów detonacyjnych w przypadku nieprawidłowego działania MUP, bądź też zbyt długiego czasu przebywania materiału w otworze strzałowym.

### **5.2. Badania walidacyjne**

Bazując na wcześniejszych wynikach badań, oraz założeniach sprecyzowanych w punkcie 3.3., przebadano szereg możliwości zmian składu uczulacza w celu modyfikacji zdolności nagazowujących oraz energetyki końcowego materiału wybuchowego. Należało przy tym



wziąć pod uwagę szereg aspektów tak, aby ewentualne wdrożenie nie było źródłem problemów podczas produkcji, transportu czy też użytkowania [E2]. Nie mogły to być substancje toksyczne czy wybuchowe, które zmieniłyby sposób pakowania czy klasyfikację transportową czy w sposób bezpośredni zagrażałyby górnikom podczas operacji związanych z tankowaniem komponentów czy załadunkiem przodków. Ostatecznie udało się uzyskać dwie formuły zgodne z powyższymi założeniami. Zmiana składu uczulacza polegała przede wszystkim na obniżeniu zawartości wody, dodatku chloranu(VII) sodu, obniżeniu zawartości azotanu(III) sodu oraz obniżeniu pH. Skład matrycy pozostał bez zmian.

Uczulanie standardowego Emulinitu 8L to powolny proces dyfuzyjny i dla zapewnienia odpowiedniej szybkości reakcji wymagana jest podwyższona temperatura komponentów. W proponowanym rozwiązaniu jakim jest modyfikacja składu uczulacza, oprócz głównej reakcji międzyfazowej, występuje reakcja wewnątrzfazowa komponentu uczulającego, co wybitnie przyspiesza uczulanie [E3]. Dodatkowo oprócz reakcji w wyniku których wydziela się gaz, zachodzi reakcja tworzenia chloranu(VII) amonu, co dodatkowo uczula i poprawia parametry strzałowe. Badania kinetyki uczulania prowadzono w temperaturze 25°C.

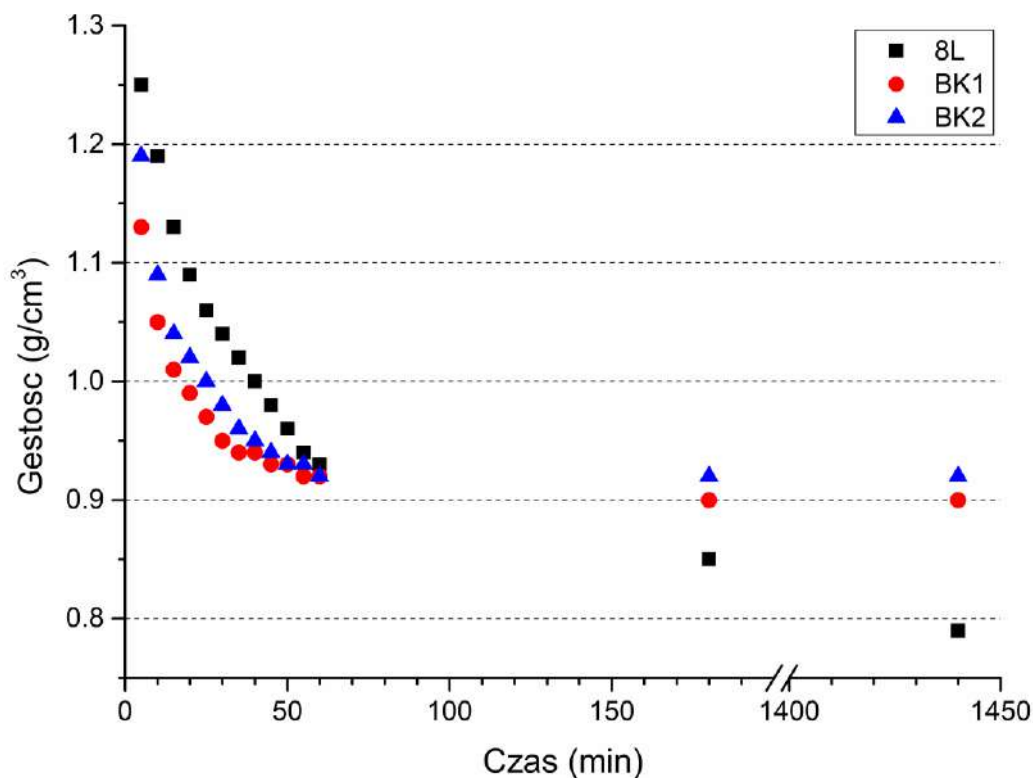

**Rysunek 12.** Wykres zmian gęstości w czasie dla Emulinitu 8L oraz dla dwóch nowych kompozycji BK1 i BK2.

Na rysunku 12 przedstawiono zależność szybkości uczulania Emulinitu 8L oraz dwóch nowych formuł BK1 i BK2 od czasu. Standardowy produkt uczula się powoli, natomiast nowe zaproponowane składy komponentu uczulającego, znacznie przyspieszają proces uczulania a gęstość szybko się stabilizuje i już po ok. 30 min. tylko nieznacznie się zmienia, w przeciwieństwie do standardowego składu, gdzie reakcja biegnie jeszcze nawet po 24 godzinach [E4].

Na podstawie powyższych badań wytypowano dwa składy komponentu uczulającego BK1 i BK2, które następnie poddano szczegółowej charakterystyce w warunkach laboratoryjnych oraz w warunkach użytkowych.

### **5.3.Laboratoryjne badania parametrów energetycznych**

Nowe kompozycje uczulacza, zostały przebadane początkowo w NITROERG S.A. w Bieruniu. Pozytywne wyniki badań pozwoliły na rozszerzenie prac i dalsze prace wykonane zostały w Jednostce Oceny Zgodności Głównego Instytutu Górnictwa we współpracy z Centrum Badawczo-Rozwojowym KGHM Cuprum.

Badania opierały się na badaniu składu gazów postrzałowych, pomiarze prędkości detonacji, badaniu ciśnienia fali podmuchowej, ocenie kruszności wg próby Hessa oraz oznaczeniu względnej zdolności do wykonania pracy.

#### **5.3.1. Badanie składu gazów postrzałowych**

Po wstępnym ustaleniu składu mieszanki uczulacza przystąpiono do badania składu gazów postrzałowych na aparaturze pomiarowej Głównego Instytutu Górnictwa [7]. Ze względu na wyeliminowanie wpływu materiału otoczki na skład gazów postrzałowych, badane MWE umieszczono w rurach szklanych z przybitką wykonaną z gliny (Rysunek 13). Szczegółowa procedura badania została opisana w publikacji [E4].



**Rysunek 13.** Przygotowane ładunki badanych MWE w rurach szklanych.

**Tabela 2.** Ilości gazów postrzałowych powstających z jednego kilograma badanych MWE.

	Ilość wydzielonych tlenków [dm <sup>3</sup> /kg]		
	<b>Emulinit 8L</b>	<b>BK1</b>	<b>BK2</b>
<b>CO<sub>2</sub></b>	118,1	120,3	118,3
<b>CO</b>	10,35	8,70	9,62
<b>NO</b>	0,52	0,30	0,29
<b>NO<sub>2</sub></b>	0,04	0,04	0,03
<b>NO<sub>x</sub></b>	0,55	0,34	0,32

Ze względu na mniejszą zawartość wody, dokładniejsze rozmieszczenie gorących punktów i pewną zawartość chloranu(VII) amonu w postaci mikrokryształów, kompozycje BK1 i BK2 charakteryzują się pełniejszą detonacją i lepszą konwersją reagentów. Gwałtowniejsza detonacja powoduje, że reakcja utleniania paliwa biegnie w kierunku tworzenia dwutlenku węgla i wody, przez co ilość szkodliwych gazów w postaci NO<sub>x</sub> i CO uległa zmniejszeniu (Tabela 2).

### 5.3.2. Pomiary prędkości detonacji

Wyniki pomiarów prędkości detonacji (Tabela 3) wyraźnie wskazują na zauważalnie wyższe parametry nowych formuł względem wzorcowego MWE, szczególnie w przypadku BK2. Wartości takie są spotykane w grupie MWE nabożowanych, co może oznaczać,

że istnieje możliwość zastosowania takiej formuły luzem w pracach strzałowych, gdzie do tej pory stosowane były jedynie mocniejsze MW.

**Tabela 3.** Wartości prędkości detonacji badanych MWE.

Badany MWE	Prędkość detonacji [m/s]		
	Emulinit 8L	BK1	BK2
<b>Wartość średnia</b>	<b>4233 +/- 32</b>	<b>4647 +/- 6</b>	<b>5033 +/- 6</b>

Dodatkowo wykonano jedno badanie VoD formuły BK1 po 24 godzinach od wymieszania. Wartość 4660m/s tylko w nieznacznym stopniu odbiega od próbek inicjowanych po trzech godzinach od załadunku.

### 5.3.3. Pomiary ciśnienia fali podmuchowej

Zaobserwowano tylko nieznaczne różnice w ciśnieniach fali podmuchowej (Rysunek 14). Próbkę zachowywały się bardzo podobnie ze względu na brak dodatków wysokoenergetycznych w postaci proszków metali czy mocniejszych MW.

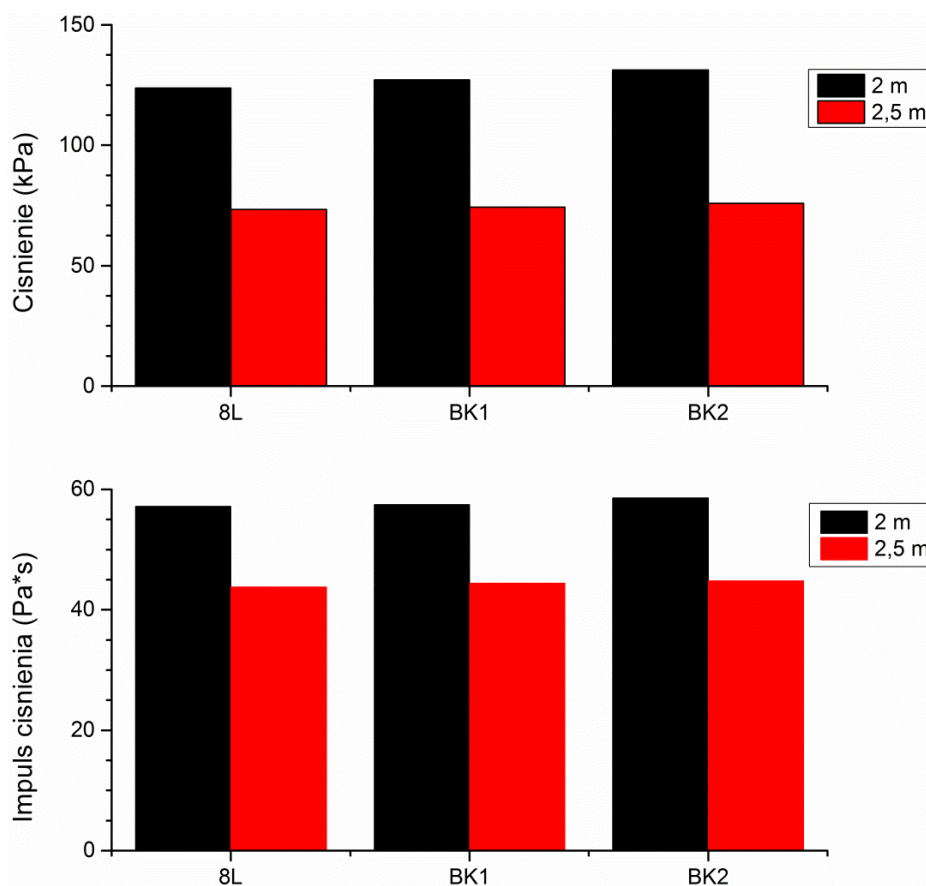

**Rysunek 14.** Przebiegi ciśnienia maksymalnego i impulsu ciśnienia detonacji badanych próbek.

### 5.3.4. Ocena kruszności metodą Hessa

Badanie wykonywane było zgodnie z normą PN-C-86033:2000. Powyższa norma jest aktualizacją normy branżowej pochodzącej z 1990r., która przewidywała zastosowanie starych, trudnych do odtworzenia rozwiązań (np. wykonanie osłonek z papieru asfaltowego), które częściowo nie były możliwe do zastosowania, z uwagi na m.in. półpłynną konsystencję badanych MWE. W związku z powyższym, opracowano modyfikację ww. metody, zastępując osłonki z papieru asfaltowego osłonkami z tworzywa sztucznego PET-G (średnica 40mm, wysokość 65mm, grubość ścianki 0,4 mm), wykonanymi techniką druku 3D. Szczegółowa procedura badania została opisana w publikacji [E4].

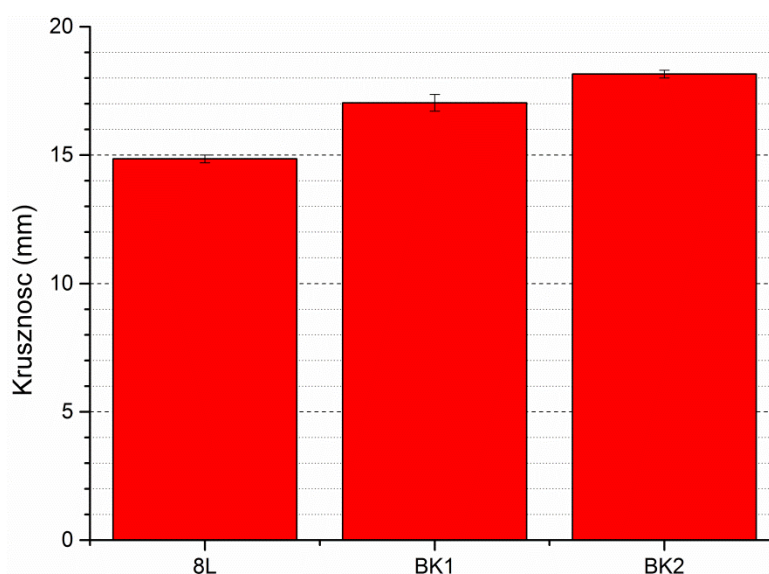

**Rysunek 15.** Wartości kruszności dla badanych MWE.

Dzięki modyfikacji metody, otrzymane wyniki były bardzo powtarzalne. W przypadku kompozycji BK2 kruszność jest o ok. 20% wyższa niż w przypadku Emulinitu 8L (Rysunek 15), przy czym współczynnik kruszności wykazywał wzrost aż o 31,91%. Jako, że kruszność zależna jest ściśle od prędkości detonacji, badania te są spójne z wynikami wcześniejszych pomiarów VoD.

### 5.3.5. Oznaczanie względnej zdolności do wykonania pracy

Wg normy PN-C-86035:2022-04, próbkę badanego MW umieszcza się w cylindrze wykonanym z folii cynowej, który bardzo łatwo ulega zdeformowaniu, co przy półpłynnych substancjach jak MWE luzem, stanowi problem w zachowaniu geometrii badanego ładunku. Podobnie jak w przypadku badań kruszności, wykorzystano tutaj druk 3D. Próbki badanych MWE luzem umieszczono w osłonkach z tworzywa sztucznego i zamknięto pokrywkami

z otworem centrującym zapalnik. Szczegółowa procedura badania została opisana w publikacji [E4].

Również w tym badaniu nowe formuły odznaczały się lepszymi o ok. 10% parametrami względem standardowej formułacji, nieco lepszymi nawet od trotylu (Tabela 4).

**Tabela 4.** Wyniki względnej zdolności do wykonania pracy.

	Heksogen	8L	BK1	BK2	TNT (łuskowany)
RWS [%]	100	62,6	68,8	69,6	67,7

### 5.3.6. Wnioski z badań laboratoryjnych.

Na podstawie wyników przeprowadzonych badań można stwierdzić, że nowe formuły BK1 i BK2 charakteryzują się lepszymi parametrami detonacyjnymi oraz stabilnością procesu uczulania i stanowią mogą znaczące ulepszenie dotychczasowego rozwiązania.

Na poprawę parametrów detonacyjnych, na pewno ma wpływ mniejsza o ok. 2% zawartość wody w wytworzonym MWE luzem. Dodatkowo w wyniku reakcji składników uczulacza i matrycy emulsji, wydziela się chloran(VII) amonu w postaci drobnokrystalicznej (Rysunek 16). Chloran(VII) amonu ma właściwości wybuchowe i w przypadku obecności nawet niewielkich ilości tego związku w MWE, stanowi dodatkowe źródło tzw. gorących punktów, przez co wzrasta wrażliwość na bodźce detonujące oraz poprawie ulega propagacja fali detonacyjnej.



**Rysunek 16.** Zdjęcia mikroskopowe badanych MWE luzem. Emulinit 8L bez wtrąceń krystalicznych (z lewej) oraz nowa formuła BK2 (z prawej) z wyraźnymi kryształami chloranu(VII) amonu.

## **5.4. Badania użyteczności w warunkach górniczych.**

### **5.4.1. Wstępne badania wrażliwości na bodźce proste.**

Przed przystąpieniem do prób dołowych, ze względów bezpieczeństwa, wykonane zostały badania wrażliwości nowych formuł na bodźce proste: tarcie i uderzenie.

W żadnej z 12 próbek pod obciążeniem 360N nie zaszła reakcja mogąca świadczyć o rozkładzie wybuchowym. Wartość ta odpowiada wynikom uzyskiwanym dla standardowego Emulinitu 8L.

Spośród 48 badanych próbek w zakresach energii uderzenia 10 J do 50 J, żadna próbka nie wykazała inicjacji (brak dźwięku, brak efektu świetlnego, brak dymu), co oznacza, że wartość wrażliwości na uderzenie nowych formuł MWE przekroczyła 50 J, podobnie jak w przypadku standardowego wyrobu.

### **5.4.2. Badania w warunkach użytkowych**

Weryfikacja użyteczności została przeprowadzona w rzeczywistych warunkach górniczych w KGHM i składała się z dwóch niezależnych prób, w których odpalano materiały wybuchowe w 4 ścianach. Wyniki urabiania przy użyciu nowego materiału wybuchowego emulsyjnego luzem o ulepszonych parametrach energetycznych BK2 porównano z wynikami uzyskanymi przy użyciu standardowego Emulinitu 8L. Badania właściwości użytkowych składały się z dwóch podziemnych prób. Pierwsze testy zostały przeprowadzone przy użyciu pojedynczego mieszalnika statycznego, a drugie z użyciem mieszalnika podwójnego. Odstęp czasu między obiema próbami wynosił dwa tygodnie.

W pierwszym podejściu z użyciem pojedynczego mieszalnika, już na wstępie zauważono problemy z niejednorodnością wpływającej z węża załadowczego mieszanki składników MWE. Potwierdziły to badania gęstości, w których próbki nie uczuły się równomiernie w danym czasie. Na uwagę zwraca fakt, że ostatni przodek ładowany był nową formułą, a odpalenie nastąpiło ok 20 minut po załadowaniu ostatniego otworu. Pomimo tak niesprzyjających warunków, i tak krótkiego czasu od załadunku do odpalenia, nie było żadnych niewypałów, a uzyskany materiał wybuchowy był parametrami zbliżony do Emulinitu 8L, który uczuł się o ponad 30 minut dłużej. Może to świadczyć o wysokim stopniu tolerancji na problemy techniczne lub błędy podczas załadunku. Badania zostały szerzej opisane w publikacji [E5].

W drugiej próbie wykonano załadunek dwóch przodków z wykorzystaniem nowej formuły uczulacza BK2 oraz dla porównania załadowano dwa przodki standardowym składem Emulinitu 8L (Rysunek 17). Wszystkie przodki znajdowały się w tym samym rejonie kopalni i miały zbliżone parametry geologiczne. Temperatura powietrza wynosiła 29,5 °C.



**Rysunek 17.** Załadunek otworów strzałowych w kopalni.

Podczas załadunku z MUP pobierane były próbki MWE w celu oznaczenia gęstości oraz zbadania kruszności metodą Hessa. W tym przypadku, wszystkie pobrane próbki uczały się równomiernie, a w przypadku formuły BK2 uzyskane gęstości już po prawie 40 minutach wartość docelową, podczas gdy Emulinit 8L uczał się dalej nawet po trzech godzinach (rysunek 18).



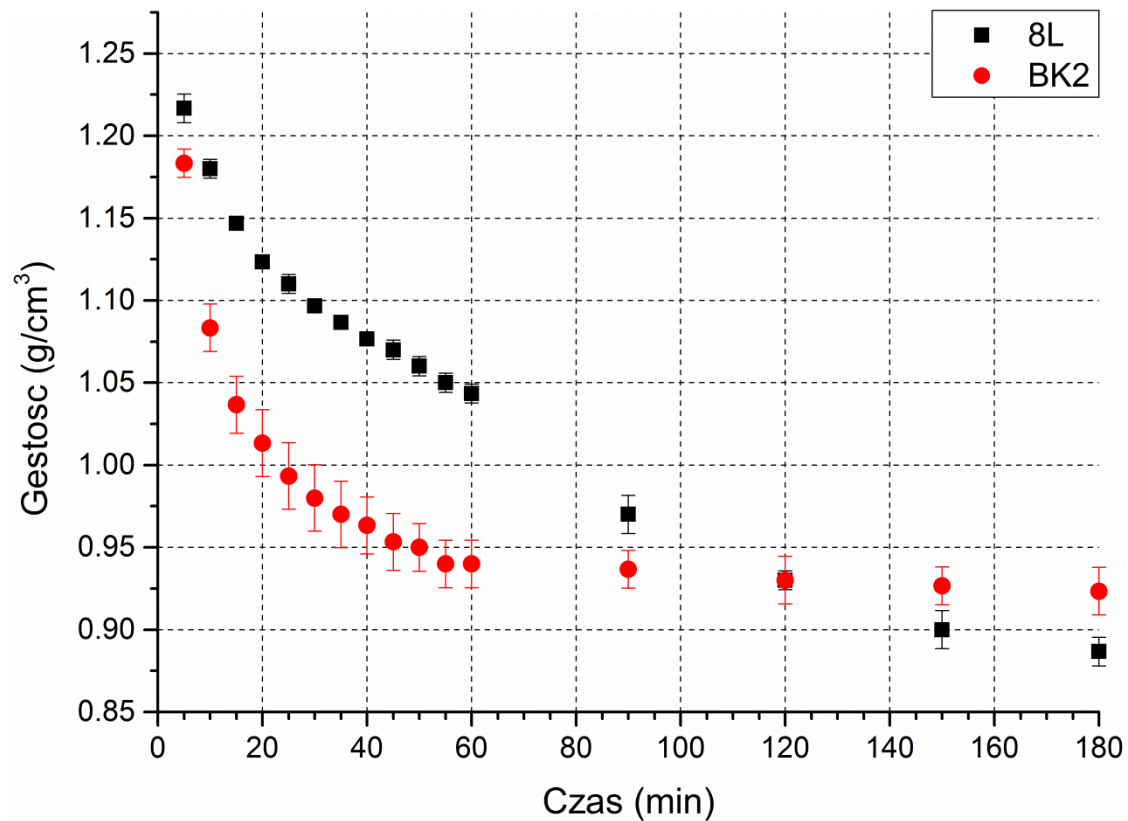

**Rysunek 18.** Zależność gęstości od czasu próbek MWE załadowanych w otworach strzałowych.

Zmierzona kruszność formułki BK2 była o ok. 8% wyższa względem Emulinitu 8L (Rysunek 19). Wynik ten znacznie odbiega od wartości otrzymanych w warunkach laboratoryjnych. Rozrzut wyników zarówno dla pomiarów gęstości i kruszności, wskazuje na niewystarczające wymieszanie komponentów nowej formuły BK2 podczas załadunku MWE luzem do otworów strzałowych.

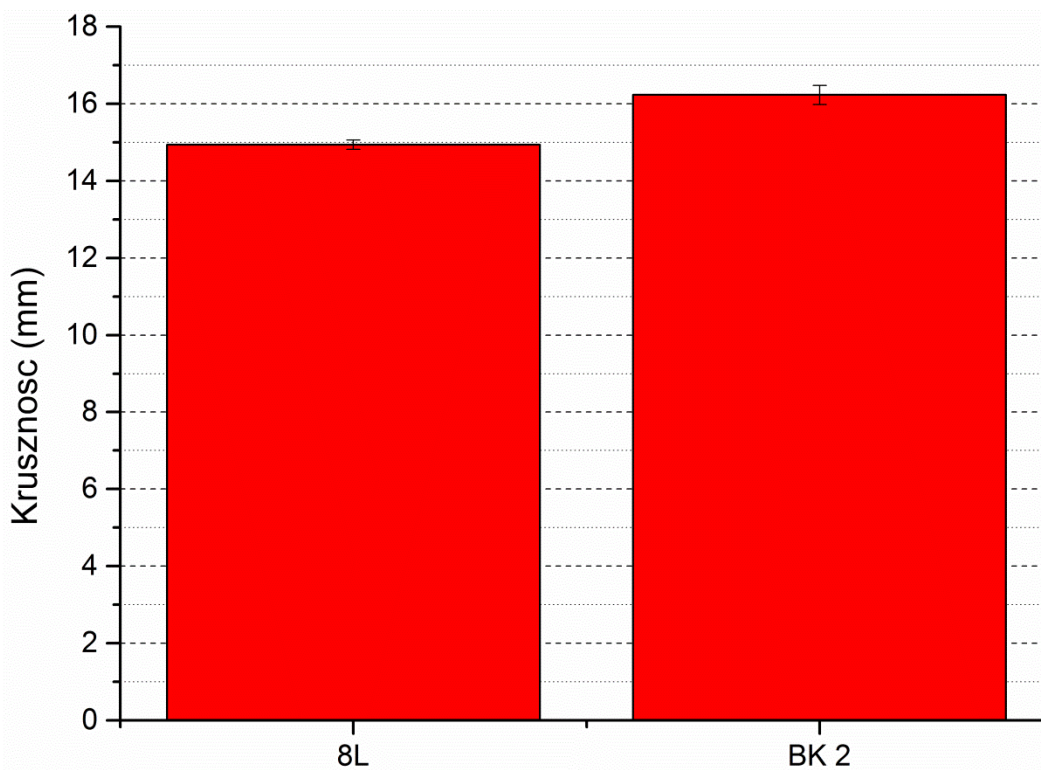

**Rysunek 19.** Krusznosc pobranych próbek MWE załadowanych w otworach strzałowych.

Na podstawie przeprowadzonych badań wykazano, że bardzo duże znaczenie na jakość końcową MWE luzem ma bardzo dokładne wymieszanie komponentów MWE luzem. MUP wyposażone są w mieszalniki statyczne, w których osiągalny stopień wymieszania składników jest funkcją m.in. lepkości dynamicznej mieszanych składników. Ponieważ nowy komponent uczulający charakteryzuje się wyższą lepkością od standardowego, użycie nawet podwójnego mieszalnika statycznego przy ładowaniu otworów strzałowych za pomocą MUP nie gwarantuje osiągnięcia wystarczająco wysokiego stopnia wymieszania komponentów. Przekłada się to na niemożność osiągnięcia w warunkach użytkowych parametrów MWE dorównujących parametrom obserwowanym we wcześniejszych próbach w warunkach laboratoryjnych.

Zaobserwowano natomiast znaczącą poprawę w zakresie szybkości i stabilności uczulania względem standardowej formuły. Materiał o wiele szybciej uzyskiwał gęstości docelowe, co jest szczególnie ważne w przypadku odpalania kilku przodków załadowanych w różnym czasie. Dzięki temu, znacząco można przyspieszyć i roboty strzałowe, co ma ogromny wpływ na efektywność i może mieć duże znaczenie ekonomiczne w procesach wydobywczych.

## 6. Podsumowanie i wnioski

W ramach pracy doktorskiej opracowano nowe formułacje MWE luzem, wyróżniające się od istniejącego stanu wiedzy zmianą składu komponentu uczulającego. Dzięki temu zmniejszyła się zawartość wody w MWE luzem o ok. 2,5%, pojawił się związek o silnie zaznaczonych właściwościach wybuchowych oraz uzyskano korzystniejszy względem wymagań praktycznych (roboty strzałowe) profil zmian gęstości uczulanego MWE luzem w czasie, cechujący się szybkimi zmianami gęstości bezpośrednio po zmieszaniu składników formułacji i występowaniem względnie niewielkich zmian gęstości w kolejnych interwałach czasowych.

Wyniki badań laboratoryjnych wskazują na wyższe pod każdym względem parametry detonacyjne nowych formuł BK1 i BK2 w porównaniu do Emulinitu 8L. W przypadku BK2 znaczącej poprawie uległy: prędkość detonacji (wzrost o 18,9%), zdolność wykonania pracy (wzrost o 10%), kruszność (wzrost o ponad 20%) oraz skład gazów postrzałowych w związku z czym, zostały spełnione wszystkie założenia tematu pracy.

Przeprowadzono badania porównawcze istniejącej formułacji (EMULINIT 8L) MWE luzem oraz formułacji opracowanej w ramach niniejszej pracy (BK2) w warunkach analogicznych do docelowych warunków użytkowych. W pierwszym etapie prób z użyciem pojedynczego mieszalnika, niedokładne wymieszanie nowej formuły skutkowało niepełnym uczuleniem, więc nie osiągnięto zamierzonego celu i nie udało się uzyskać parametrów zmierzonych w warunkach laboratoryjnych.

Dzięki zastosowaniu podwójnego mieszalnika w drugim etapie badań, uzyskano lepszy stopień wymieszania komponentów, ale nadal nie było to w pełni równomierne wymieszanie gdyż układ mieszalnika MUP został zaprojektowany dla standardowej formuły MWE.

Pomimo nadal występujących problemów z pełnym wymieszaniem, zachowana była zależność gęstości od czasu. Uzyskano również wyższe wartości kruszności w porównaniu do standardowego Emulinitu 8L, ale nie udało się uzyskać wartości parametrów z testów laboratoryjnych i nie przełożyło się to bezpośrednio na fragmentację urobku.

Opracowany materiał spełnia wszystkie wymagania bezpieczeństwa i techniczne dotyczące ładunku mechanicznego a po dopracowaniu systemu mieszania, tak aby zapewnić wystarczająco wysoki stopień wymieszania komponentów ładowanych do otworów strzałowych, z powodzeniem może zastąpić dotychczasową formułę.

## **7. Znaczenie pracy i wpływ jej wyników na rozwój nauki i techniki**

Opracowanie nowej formułacji MWE luzem nakierowane jest na poprawienie efektywności urabiania skał oraz minimalizację emisji toksycznych gazów. Osiągnięcie powyższych założeń, stwarza możliwość szerokiego stosowania nowego materiału, zwłaszcza w obszarach górnictwa podziemnego po wprowadzeniu nowych norm środowiskowych oraz możliwość rozszerzenia zastosowania na nowe obszary np. przy eksploatacji twardych, zwięzłych calizn skalnych, poprzez zastąpienie innych materiałów wybuchowych (np. dynamitów) stosowanych do urabiania tych skał.

Dodatkowo, niniejsza praca dostarcza pierwszych informacji o procesie hybrydowego uczulania MWE luzem, polegającego z jednej strony na klasycznym układzie wydzielania drobnych pęcherzyków gazu, a z drugiej na tworzeniu się drobnokrystalicznej formy chloranu(VII) amonu, co dodatkowo uwrażliwia na bodźce detonacyjne i pozytywnie wpływa na proces uwalniania energii z MWE na drodze detonacji [E4].

## **8. Wdrożeniowy potencjał uzyskanych wyników**

Przedstawione i opracowane w ramach pracy doktorskiej nowe rozwiązanie polega na zmianie tylko jednego komponentu w produkowanym obecnie MWE luzem i nie ingeruje w skład matrycy emulsji. W związku z tym, nie ma konieczności wprowadzania zmian technologicznych na istniejącej instalacji produkcyjnej. Konieczne jest natomiast opracowanie i wykonanie niezależnego stanowiska do wytwarzania nowego komponentu uczulającego. Wymagana będzie również modyfikacja i dopasowanie mieszalnika statycznego na MUP w celu zoptymalizowania procesu mieszania komponentów.

Dzięki wdrożeniu do produkcji nowo opracowanej formuły, możliwe będzie zwiększenie obszarów zastosowań produkowanych MWE luzem, które z pewnością wpłynie na wzrost sprzedaży a w konsekwencji zwiększy wykorzystanie zdolności produkcyjnych instalacji do produkcji MWE i obniży koszty eksploatacji linii, zakupu surowców, mediów poprzez wykorzystanie efektu skali.

Powyższe przełoży się zarówno na korzyści finansowe jak i wizerunkowe, wynikające z uzyskania przewagi konkurencyjnej NITROERG S.A. z uwagi na innowacyjność tego rozwiązania.

Szacuje się, że w przypadku osiągnięcia pozytywnych efektów pracy, sprzedaż tylko do KGHM może się zwiększyć o około 15% masowo ze względu na obszary wymagające zastosowania materiałów wybuchowych o zmodyfikowanych parametrach strzałowych.

## 9. Literatura

- [1] Bluhm H.F. Ammonium Nitrate Emulsion Blasting Agent and Method of Preparing Same. Patent US 3447978, 1969.
- [2] Zhang K.; Zhao H. Perspectives in the stability of emulsion explosive. *Advances in Colloid and Interface Science*. Volume 307, 2022, 102745.
- [3] Zhao, H.r.; Wu, J.; Xu, M.x.; Zhang, K.m. Advances in the rheology of emulsion explosive. *J. Mol. Liq.* 2021, 336, 116854.
- [4] Lyashenko, V.; Vorob'ev, A.; Nebohin, V.; Vorob'ev, K. Improving the efficiency of blasting operations in mines with the help of emulsion explosives. *Min. Miner. Depos.* 2018, 12, 95–102.
- [5] Pham, D.H.; Le, B.D.; Nguyen, C.T.; Tran, H.T. Modeling the fracture behavior of Ultra-High Performance Fiber Reinforced Concrete slabs under contact Blast Loading. *IOP Conf. Ser. Mater. Sci. Eng.* 2020, 869, 052079.
- [6] Hattori, K.; Fukatsu, Y.; Takahashi, M. Water-in-oil Emulsion Explosive Composition. U.S. Patent 4,326,900, 27 April 1982.
- [7] Zawadzka-Małota, I. Testing of mining explosives with regard to the content of carbon oxides and nitrogen oxides in their detonation products. *J. Sustain. Min.* 2015, 14, 173–178.
- [8] Khomenko, O.; Kononenko, M.; Myronova, I. Blasting Works Technology to Decrease an Emission of Harmful Matters into the Mine Atmosphere. *Annual Scientific-Technical Collection – Mining of Mineral Deposits*. Leiden, The Netherlands: CRC Press/Balkema, 2013, pp. 231-235.
- [9] Nations, U. European Agreement Concerning the International Carriage of Dangerous Goods By Road (Adr). 2021. Available online: <https://unece.org/transportdangerous-goods/adr-2021-files> (accessed on 1 July 2022).
- [10] Mishra A.K., Rout M., Jana S.P.; Influence of Gassing Agent and Density on Detonation Velocity of Bulk Emulsion Explosives, *Geotechnical and Geological Engineering* 2018, 36, 89–94

- [11] Cheng Y., Ma H., Liu R., Shen Z.; Explosion Power and Pressure Desensitization Resisting Property of Emulsion Explosives Sensitized by MgH<sub>2</sub>, *Journal of Energetic Materials* 2014, (3), vol. 32
- [12] Laskownicki S., Maćkowiak Z., Gołąbek B., Kasperski J., Mechanizacja robót strzałowych w zakładach górniczych KGHM Polska Miedź S.A. z zastosowaniem materiałów wybuchowych emulsyjnych luzem [Mechanization of blasting works in the KGHM Polska Miedź SA mine employing bulk explosives], *Górnictwo i Geoinżynieria*, 2004, 28 (3/1), 219-230.
- [13] Mertuszka P., Fuławka K., Cenian B., **Kramarczyk B.**; Wpływ sposobu pobudzenia materiału wybuchowego emulsyjnego luzem na prędkość detonacji na przykładzie Emulinitu 8L, *Przegląd Górniczy* 2017, nr 5/2017, str. 8-16.
- [14] Specyfikacje techniczne materiałów wybuchowych produkowanych przez NITROERG S.A.
- [15] Mertuszka P., **Kramarczyk B.**, Cenian B.; Zmiany prędkości detonacji MW emulsyjnego luzem w funkcji czasu na przykładzie Emulinitu 8L, *Przegląd Górniczy* 2017, nr 3/2017, str. 10-14.
- [16] Cheng, Y.F.; Ma, H.H.; Shen, Z.W. Detonation characteristics of emulsion explosives sensitized by MgH<sub>2</sub>. *Combust. Explos. Shock Waves* 2013, 49, 614–619.
- [17] Biegańska J.; Using Nitrocellulose Powder in Emulsion Explosives. *Combust. Explos. Shock Waves* 2011, 47(3): 366-368.
- [18] Sharma, P D. *Journal of Mines, Metals and Fuels* 2005; Vol. 53; 90.
- [19] Moreau K., Laamanen C., Bose R., Shang H., Scott J.A.; Environmental impact improvements due to introducing automation into underground copper mines. *International Journal of Mining Science and Technology* 2021, 31, str. 1159 – 1167.
- [20] Mertuszka P., **Kramarczyk B.**, Pytel W.; Influence of Explosive Charge Diameter on the Detonation Velocity Based on Emulinit 7L and 8L Bulk Emulsion Explosives, *Central European Journal of Energetic Materials*, 2018, Vol. 15 (2), str. 351-363.

- [21] Trzeciński W., Szymańczyk L., **Kramarczyk B.**; Determination of the Equation of State for Detonation Products of Emulsion Explosives, *Cent. Eur. J. Energetic Materials*, 2019, 16(1): 49-64.
- [22] Fabin M., Jarosz T.; Improving ANFO: Effect of Additives and Ammonium Nitrate Morphology on Detonation Parameters, *Materials* 2021, 14, 5745.
- [23] Maranda A., Drobysz B., Paszula J.; Badania parametrów detonacyjnych materiałów wybuchowych emulsyjnych o niskiej gęstości modyfikowanej mikrobalonami, *Chemik* 2014, 68, 1, 17–22.
- [24] Negovanović M., Kričak L., Milanović S., Dokić N., Simić N.; Ammonium Nitrate Explosion Hazards, *Underground Mining Engineering*, 2015, 27, 49-63.
- [25] Kovalchuk K., Masalova I.; Factors influencing the crystallisation of highly concentrated water-in-oil emulsions : a DSC study, *South African Journal of Science* 2012, Vol. 108, 3.
- [26] Mertuszka P., Pytlik M. Analysis and Comparison of the Continuous Detonation Velocity Measurement Method with the Standard Method. *Mater. Wysokoenerg. (High Energy Mater.)* 2019, 11(2): 63-72.



Review

# Emulsion Explosives: A Tutorial Review and Highlight of Recent Progress

Bartłomiej Kramarczyk <sup>1,2</sup>, Krystyna Suda <sup>2,†</sup>, Patrycja Kowalik <sup>2,†</sup>, Kuba Swiatek <sup>2,†</sup>, Katarzyna Jaszcz <sup>2</sup> and Tomasz Jarosz <sup>2,\*</sup>

<sup>1</sup> NITROERG S.A., 1 Alfred Nobel Square, 43-150 Bierun, Poland; b.kramarczyk@nitroerg.pl

<sup>2</sup> Faculty of Chemistry, Silesian University of Technology, 44-100 Gliwice, Poland; kryssud364@student.polsl.pl (K.S.); patrkow960@student.polsl.pl (P.K.); kubaswi454@student.polsl.pl (K.S.); katarzyna.jaszcz@polsl.pl (K.J.)

\* Correspondence: tomasz.jarosz@opayq.com

† Student at the Faculty of Chemistry.

**Abstract:** Emulsion explosives (EE) have been commercially available in various forms for over 50 years. Over this period, the popularity and production technology of this class of energetic materials have been developing constantly. Despite this rapid rise to prominence and, in some applications, prevalence over traditional energetic materials, remarkably little information is available on the physicochemical and energetic properties of these materials and factors affecting those properties. This work is dedicated to presenting the fundamental information relevant to the features, properties and applications of EEs, while highlighting the most significant recent progress pertaining to those materials. Particular emphasis has been given to providing information about the types, composition, modifications and detonation parameters of EEs, as well as to highlighting the less obvious, emerging applications of EEs.

**Keywords:** emulsion explosive; energetic material; ammonium nitrate; detonation; ANFO



**Citation:** Kramarczyk, B.; Suda, K.; Kowalik, P.; Swiatek, K.; Jaszcz, K.; Jarosz, T. Emulsion Explosives: A Tutorial Review and Highlight of Recent Progress. *Materials* **2022**, *15*, 4952. <https://doi.org/10.3390/ma15144952>

Academic Editor: Eduardo J. Garcia-Suarez

Received: 31 May 2022

Accepted: 14 July 2022

Published: 15 July 2022

**Publisher's Note:** MDPI stays neutral with regard to jurisdictional claims in published maps and institutional affiliations.



**Copyright:** © 2022 by the authors. Licensee MDPI, Basel, Switzerland. This article is an open access article distributed under the terms and conditions of the Creative Commons Attribution (CC BY) license (<https://creativecommons.org/licenses/by/4.0/>).

## 1. Introduction

Emulsion explosives (EE) are one of the most recently developed classes of energetic materials [1–5] and can be perceived as a step forward from the traditional energetic materials based on ammonium nitrate (AN), such as amatols, ammonals and ANFO (ammonium nitrate-fuel oil). EEs are obtained by physically or chemically sensitising an “EE matrix”, which is a water-in-oil emulsion, containing at the very least ammonium nitrate, water, oils and a surfactant [6].

The unique feature of EE matrices is that they are insensitive to initiation and cannot sustain detonation without being sensitised. This feature resulted in them being classed as oxidising agents, specifically with no. UN 3375, being assigned to class 5.1 as per ADR/RID regulations [7]. Due to this classification, the requirements for transporting EE matrices are much less stringent than the requirements for transporting traditional energetic materials (which are assigned to ADR/RID class 1).

The facile transportation of EE matrices was the key factor underlying the development of bulk emulsion explosives. Bulk EEs, which are a novel form of energetic materials, can be produced directly within boreholes. This is achieved via loading the boreholes with a mixture of the EE matrix and a chemical sensitising agent. This approach eliminates the need for transporting and handling explosive materials prior to the blasting operation, while allowing remote loading of boreholes. The key advantages of bulk EEs in comparison with traditional cartridge energetic materials are increased safety and facile borehole loading.

Recent years have also brought about a significant improvement in the performance of bulk EEs [8], resulting in their increasingly popular use, particularly in comparison with

cartridged EEs (Figure 1), as their usage share in the total usage of EEs has exceeded 85% in 2018 and is expected to have risen even further in the last several years. The primary application of EEs is in blasting operations oriented towards open pit and underground mining. The development and commercialisation of coal dust- and methane-permitted EEs has also contributed to area of application, allowing bulk EEs to compete with traditional energetic materials in this area as well. Considering the scale, on which bulk EEs are utilised annually, even seemingly minor, incremental improvements of their performance are expected to have significant economic impact and improvements to the safety parameters of bulk EEs are of even greater importance. Consequently, developing new EE formulations exhibiting improved properties is highly desirable from a number of viewpoints.

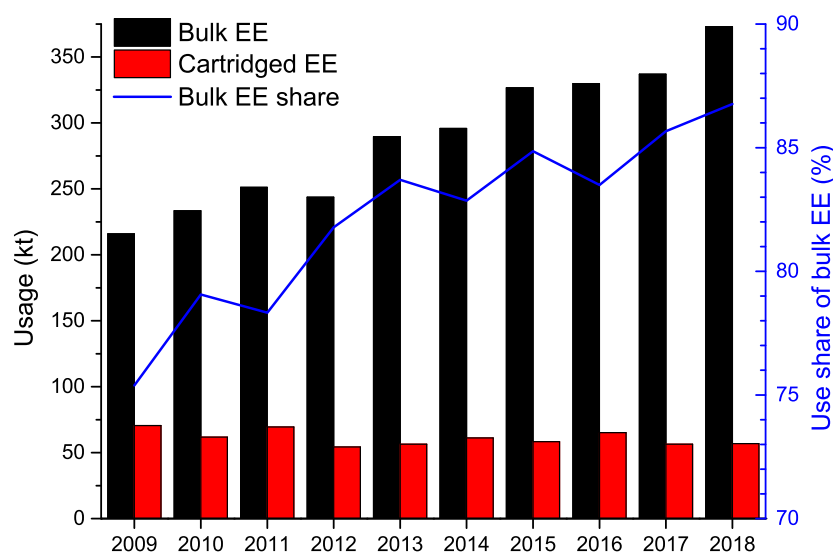

**Figure 1.** Usage of bulk and cartridged EEs and share of bulk EEs in the total usage of EEs in Europe (EU member states, Norway and Switzerland) over recent years. Data provided courtesy of the Federation of European Explosives Manufacturers

The rational development of EEs requires a thorough understanding of the processes occurring in the manufacture and handling of EE matrices, as well as those associated with chemically sensitising EEs. Despite the increasing popularity of EEs, however, no comprehensive source of the above information is available in the scientific and technical literature. The sole recent review of advances in the rheology of EEs [9] is a valuable work, but does not facilitate access to the subject as it focuses on a highly-specialised subject area. This work is supplemented by a more dated summary of the issues of the stability and rheology of EE matrices [10]. Even so, the available literature results in high entry requirements for the subject, translating into its limited accessibility, significantly hindering the development of EEs.

In light of the above, this tutorial review was intended to comprehensively collect the essential and fundamental information about various aspects of EEs for the first time, so as to facilitate access to the subject of EEs by non-specialists. The collated account of recent developments relevant to EEs can both serve as examples of current issues and means of highlighting the most significant developments in the subject area.

## 2. Stability of EE Matrices

Emulsions are thermodynamically unstable dispersion systems that are susceptible to aging via, e.g., Ostwald ripening, flocculation, creaming and coalescence, resulting in phase separation and a gradual deviation from the properties of the initial emulsion [11]. Due to the high volume fraction of the dispersed phase in the EE matrices, they are highly resistant to flocculation and creaming [12]. Instead, the most relevant mode of EE matrix aging is that of emulsion-to-suspension transition, due to the gradual crystallisation of ammonium

nitrate [9]. Studies of this crystallisation process have revealed that it takes place in the EE matrix droplets oversaturated with ammonium nitrate, resulting in the formation of pure ammonium nitrate crystals and droplets of unsaturated ammonium nitrate solutions [13].

The choice of emulsifying agent used to produce the EE matrices is highly relevant to the stability of the EE formulation. In the case of poly(isobutylene)-succinic anhydride (PIBSA) modified with either diethanolamine or with poly(ethylene glycol) oligomers, the choice of emulsifying agent was found to have a significant impact on the stability and rheological properties of EE matrices [14]. Interestingly, even though two compounds exhibiting high performance (preventing phase separation and resulting in a minimal loss of ammonium nitrate from the EE matrix during aging studies) were identified, the hydrophile-lipophile balance of the emulsifying agents was found to have little correlation on their efficacy.

In a further study, a more diverse choice of emulsifying agents, as well as their mixtures has been tested [15], revealing that polymeric emulsifying agents were in general more effective in maintaining the EE matrix than low-molecular agents, despite them affording higher interfacial tension values than those afforded by low-molecular agents. Interestingly, among the tested emulsifying agents, polypropylene (denoted as H036) was found to be more effective than agents bearing various functional groups.

### 3. Approaches to Sensitising EEs

The production safety philosophy of EEs is that non-explosive components are mixed together to form an emulsion, which is referred to as the “EE matrix”. The matrix is not an explosive, as its density and homogeneity do not allow for supporting the detonation processes. To achieve the transition from this non-explosive state to an explosive state, in which the EE is capable of sustained detonation, the EE matrix must be sensitised. Sensitising consists of supplementing the matrix with substances that lower the density and introduce homogeneity “defects”, such as small gas-filled spheres, which constitute hot-spots. Upon detonation, the gas bubbles (hot-spots) absorb energy, heating up to high temperatures, allowing the detonation to be sustained. Physical and chemical sensitisation methods are employed, with the choice of method being strongly correlated with the type of EE (cartridged or bulk) being sensitised.

Physical sensitisation consists of supplementing the EE matrix with glass microspheres (tiny glass beads of very low density) and is the prevalent form of sensitisation for producing cartridged EEs. Chemical sensitisation, on the other hand, is mainly employed for bulk EEs. It relies on the reaction of the sensitising agent with oxidising agents constituting the EE matrix, as this reaction results in the evolution of gas that produces small bubbles across the entire volume of the sensitised matrix. In both cases, sensitisation results in the density of the EE matrix decreasing.

An important consideration for sensitised EEs is that of the optimal size and population of the low-density (microspheres or gas bubbles) defects—“pores” in the EE volume. It has been found that the diameter of the pores in sensitised EEs strongly impacts their detonation velocity and critical diameter [16]. Consequently, this aspect of sensitisation should also be taken into account during the development of EEs, with control over the dimensions and distribution of pores likely being the key aspects of developing new EE sensitisation methods. In the case of physical sensitisation, there is no problem with maintaining uniform pore size. Microspheres can readily be manufactured to have a narrow size distribution. In the case of chemical sensitisation, however, the size of the gas bubbles depends primarily on the type of sensitising agent, sensitisation time, temperature and EE matrix viscosity. Nitrogen released in the reaction of sodium nitrite with ammonium nitrate in the initial phase of sensitisation generates very small bubbles. As the reaction proceeds, they begin to increase in volume until all the sodium nitrite has been reacted. The bubbles should be as small as possible and perfectly distributed throughout the mass of the emulsion.

### 3.1. Physical Sensitising

Physical sensitisation relies on adding solid spheres that are filled with gas to the EE matrix. Glass and polymer microspheres are most commonly used for the purpose of physical sensitisation, but perlite is sometimes used as well [17,18]. The amount of sensitising agent in the final EE formulation is typically in the range of 1–4 wt.%, depending on the type of microspheres and the desired density of the final EE. Polymer microspheres are more effective in reducing density than glass ones [19]. It should be noted, however, that the comparison between the two types of microspheres was conducted based on the density of the sensitised EEs rather than on their weight share in the formulation and the nearly twofold difference in microsphere diameters is likely a highly significant factor. Despite this potential unresolved issue, polymer microspheres have a significant advantage in their facile processing, enabling their fabrication directly on-site. The use of perlite is currently declining, due to the rapidly developing technology for the production of glass microspheres.

In terms of the physical sensitisation of EEs, cenospheres appear to be a viable alternative to glass and polymer microspheres [20], as velocity of detonation (VoD) reported for cenosphere-based EEs are comparable to those reported for glass microsphere-based EEs. The added value of cenospheres in comparison with other types of physical sensitising agents is that they are a waste material and as such require no significant energy or material investments to be obtained.

### 3.2. Chemical Sensitising

Chemical sensitisation is mainly used for bulk EE. In some cases this type of sensitisation is also used for the cartridges. It involves a chemical reaction between the sensitising solution and the oxidising agent phase of the EE matrix. Aqueous solutions of sodium nitrite are primarily used as chemical sensitising agents. The use of sodium nitrite is based on a reaction between sodium nitrite and acidified ammonium nitrate in the presence of thiourea. This reaction produces nitrogen which, in the form of micro bubbles, fills the entire volume of the emulsion, reducing the density and creating hot spots. The rate of this reaction is strictly dependent on the temperature of the components and the reaction continues until one of the reagents is depleted. Chemical sensitisation can be problematic in cold environments, sometimes necessitating additional acidification, in order to achieve the desirable rate of the sensitisation reaction [21].

The reaction underlying chemical sensitisation, i.e., the reaction of nitrite anions and ammonia cations, exhibits relatively slow kinetics. Such kinetics translate into the properties of the EE being strongly dependent on the time elapsed between the sensitisation and initiation (“sleep time”) of the EE charge. A strong dependence of properties on time is sub-optimal, as in order to achieve the planned performance of the EE, a precise timing would be required. Instead, it is more favourable for the majority of changes in the properties of the EE to take place nigh-immediately upon sensitisation and to be followed by a period of noticeably lesser changes.

Due to the above, methods of improving the kinetics of the sensitisation reaction were investigated, resulting in the introduction of thiourea as a substance reacting more readily with nitrite anions than the ammonia cations present in the system [22]. The kinetics of the sensitisation reaction can also be augmented with the use of calcium and strontium cations. These additives have also been found to promote the nitrite-ammonium reaction [23]. Although no mechanism underlying this process was proposed, the introduction of such cations was found to increase the rate of sensitisation, generate smaller and more uniformly dispersed gas bubbles and increase the stability of the sensitised EE.

More recent work on the subject of chemical sensitisation has been dedicated to supplementing the fuel phase with cocoa fat and stearic acid [24]. Supposedly, this addition stabilises the sensitisation process, resulting in an EE exhibiting a homogeneous distribution of nitrogen gas bubbles that is stable for no less than 96 h. Although no material evidence has been given to support these claims, the postulated additives are used in significant

amounts and in light of them being noticeably more expensive than the other components of EEs, there may be little economic justification for including them in the EE formulation.

An alternative route to chemically sensitising EEs relies on a reaction between ammonium nitrate and hypochlorites [25]. Although the reaction is described as less hazardous than chemical sensitising with the use of thiourea, this may be debatable, as the reaction yields chloramine as an intermediate product, which may be transformed into highly toxic hydrazine, depending on the reaction conditions [26]. Another potential issue of this invention is that the rate of sensitisation is difficult to control, even with the use of a variety of surfactants, due to the high reactivity of the reagents.

Although much less prominent than the composition of post-detonation gases and threats arising therefrom, the emission of hazardous gases from boreholes containing EE undergoing sensitisation is also a significant risk to personnel. In the case of the nitrite-ammonium reaction, both the inert nitrogen and the hazardous nitric oxide (NO) are produced. It has recently been found that the emission of the latter can be mitigated with the use of nitrosoaromatic sulfonates, such as 5-dimethyl-4-nitrosobenzene sulfonate [27]. Even an addition of 1% wt. of this compound was found to reduce NO emissions from the EE by approx. 70%. That said, it is unclear how the inclusion of such a compound and the retention of NO within the EE may affect its energetic performance or the composition of post-detonation gases, making the usefulness of this novel approach an open question.

#### 4. Additives to EEs

Emulsion explosives (EEs) typically exhibit moderately high energetic parameters, such as an ability to perform mechanical work on the order of 80–85% of that exhibited by RDX [8] and a velocity of detonation on the order of up to 4000–4500 m/s. While these parameters are adequate for most civilian applications, they may be insufficient for blasting operations in hard rocks, where the use of nitroester-based energetic materials is prevalent. In order to allow EEs to compete against traditional energetic materials in such areas of applications, it is necessary to improve their energetic performance. The most common approach to augmenting the energetic parameters of EEs involves supplementing them with a variety of additives.

The most commonly employed additives are metal powders, particularly low density metals, such as aluminium and titanium, however more sophisticated as well as simple inorganic compounds of metals, such as their hydrides. The exothermic combustion of metals not only increases the detonation temperature and the positive blast phase duration, but also helps reduce the amount of nitrogen oxides in the post-detonation gases, via promoting dissociation and disintegration of their precursor radicals [28]. The addition of aluminium powder to bulk EE appears to promote its sensitisation, as increasing the Al content in the formulation has led to decreased EE density 60 min after sensitisation [8]. Although this lowered EE density translates into lower detonation velocity, the overall explosive strength and Trauzl expansion parameters are also increased by approx. 5% and 17% respectively, when compared to the formulation that was not supplemented with Al. Supplementing EEs with titanium powder has a similar effect, as the addition of Ti was found [29] to result in increased brisance, explosion impulse and shock wave energy. In contrast to the use of Al and boron as additives, Ti has the advantage of having a less adverse impact on the thermal stability of the formulation.

An interesting and environmentally-friendly modification to physically sensitised EEs is to replace hollow or air-filled microballoons with ones filled with hydrogen [30]. Two types of microballoons were studied, with hydrogen filling slightly increasing brisance, detonation velocity and shock impulse (Figure 2). A similar approach to introducing hydrogen into EE formulations relies not on including it within microballoons, but chemically bound, in the form of titanium hydride, which appears to combine the advantages of supplementing EEs with titanium with those achieved by supplementing them with hydrogen [31]. The supplementation resulted in a significant improvement in explosion strength and detonation velocity (increased Trauzl test result by 30% and detonation velocity by 3%

in comparison with the unsupplemented EE formulation). The performance was found to also be improved in comparison with a formulation supplemented only with Ti powder, possibly indicating a new direction for EE formulation optimisations.

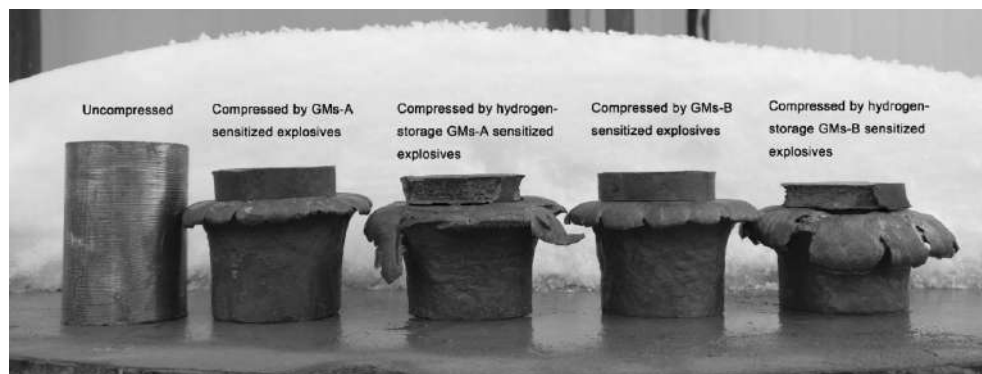

**Figure 2.** Hess test (lead column compression) results for EEs sensitised with various types of microspheres. Reprinted with the permission of Wiley from [30]. Copyright 2018.

Modifying the bulk EE sensitising agent solution intended to fine-tune the changes taking place during sensitisation is a novel approach [32], bringing about an improvement to the energetic parameters achievable for EEs. An important advantage of this approach is that it does not require any modification of the EE matrix formulation, making it compatible with existing EE manufacturing and loading solutions. In terms of EE performance, this approach was found to afford increased brisance (by up to 32%) and detonation velocity (by up to 19%), while limiting the emission of carbon monoxide during detonation, compared to a standard commercial EE formulation. An added value of this approach is an improvement to the kinetics of sensitising process, with the density of the modified formulations decreasing more rapidly than the commercial EE formulations and maintaining a more stable density after this initial change, making for a more user-friendly explosive for blasting operations.

## 5. Energetic Properties of EEs

### 5.1. Velocity of Detonation

Velocity of detonation (VoD) is among the parameters that are most commonly used for describing the performance of energetic materials. It is the maximum velocity at which a detonation wave can propagate in a given energetic material. The VoD value is a function of both the physicochemical properties of the energetic material formulation (e.g., chemical composition, density) and the features of the investigated charge (e.g., charge diameter).

Of the aforementioned parameters, the influence of density on the VoD of EEs has been studied in greatest detail. In general, the VoD of EEs increases with density to a certain critical point, at which a maximum VoD value is observed. Increasing EE density beyond this results in a rapid decrease of VoD, followed by the inability of the EE to undergo detonation (Figure 3). It should be noted, however, that the measured density of the EE is a function of both the population of pores and their size distribution, therefore the same charge density may result from different combinations of these two parameters. Consequently, the shape of the VoD vs density curve may vary, depending on the sensitisation method (with physical sensitisation being expected to afford higher pore size distribution repeatability than chemical sensitisation methods).

EEs are considered to exhibit a relatively high contact between the oxidising agent and the fuel, due to their highly dispersed phase volume concentration, exceeding the limit achieved for suspensions. This property allows excellent detonation parameters to be obtained for EEs, unlike what is seen for the more traditional energetic materials utilising ammonium nitrate (e.g., ANFO). The differences can be seen mainly in the velocity of

detonation. While traditional ANFO-type materials can barely achieve a VoD on the order of 3000 m/s, EEs typically achieve VoD values in excess of 4500 m/s.

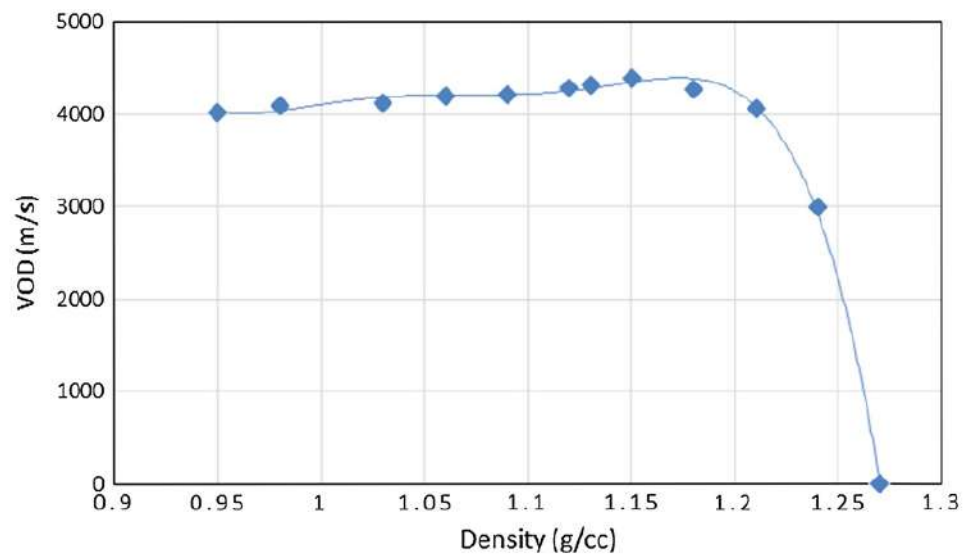

**Figure 3.** Dependence of VoD on the density of a chemically sensitised EE. Reprinted with permission of Springer Nature from [33]. Copyright 2017.

In the case of cartridge EE, the velocity of detonation is constant over time, as physical sensitisation is typically highly stable, due to the use of microballoons. Despite being stable over time, cartridge EEs are susceptible to elevated temperature, a fairly frequent circumstance in blasting operations, with rock strata temperatures in underground mines often having a temperature in excess of 40–50 °C. At such temperatures, the EE is partially or completely liquefied, which significantly changes its performance. Simultaneously, elevated temperature can promote phase separation phenomena, particularly crystallisation of ammonium nitrate. It has been found that conditioning cartridge EEs at elevated temperatures even for 2–3 h was sufficient to result in a noticeable decline in VoD in regards to the initial VoD value [34].

In contrast to cartridge EEs, the use of chemical sensitising for bulk EEs offers lower stability, as the reaction underlying the sensitisation of the EE cannot be stopped at will. Consequently, for bulk EEs, the time elapsed between sensitising the EE matrix loaded into a borehole and initiating the charge, which is often referred to as “sleep time”, results in changes in the density and VoD of the EE. Moreover, the magnitude and pace of the change in the properties of the EE during the sleep time is dependent on environmental factors, primarily temperature [34].

An interesting observation is that during the gradual decrease in bulk EE density, the VoD does not continuously decrease but initially increases, likely due to the growing population of hot spots within the EE. The sleep time interval and EE density corresponding to peak VoD are not constant, even for a single EE formulation, as changing the speed of the pump used for loading the EE into the borehole was found to influence the occurrence of this VoD peak, likely due to achieving different degrees of mixing between the EE matrix and sensitising agent [35].

In another study, for an EE at room temperature, a sleep time of 15 days was found to result in VoD declining by approximately 10%, with a greater decline being observed for EE in boreholes than for unconfined EE samples [36] (Table 1).

Such changes to the VoD value of the EE formulation are highly undesirable, particularly when blasting is conducted under a variety of external conditions, as the rates of EE sensitisation and, therefore, the performance of the energetic material will vary significantly.

An obvious question, related to the issue of loss of EE energetic performance during sleep time, is that of the limit of this loss in the long term. Although the loss of performance, including the decline of VoD, was found to gradually decelerate, it has been observed to continue taking place even after 6 months have elapsed since loading the sensitised EE into plastic tubes [37]. Interestingly, even though the commercially available Emulinit 8L EE required the use of a booster charge to be initiated after 6 months, it still achieved approx. 70% of the original VoD value.

**Table 1.** Effect of sleep time on the VoD of EEs [36,37].

Density [kg/m <sup>3</sup> ]	Sleep Time	VoD [m/s]
<b>Unconfined EE</b>		
1120	0 days	4130
1100	3 days	4200
1090	6 days	4100
1110	9 days	4000
1120	12 days	3840
1100	15 days	3780
<b>EE in Borehole</b>		
1120	1 day	4920
1130	7 days	4706
1160	15 days	4359
<b>EE in Plastic Tubes</b>		
-	30 min	4230 ± 105
-	60 min	4005 ± 40
-	180 min	3732 ± 20
-	24 h	3543 ± 27.5
-	48 h min	3420 ± 32.5
-	7 days	3330 ± 40
-	14 days	3153 ± 25
-	31 days	3100 ± 12.5
-	4 months	3017 ± 15
-	6 months	2930 ± 25

It is important to note that multiple factors can simultaneously affect the performance of EEs. It has been recently found that, despite the density and viscosity of a EE formulation being monitored, the velocity of detonation (VoD) was found to vary significantly for charges in boreholes across different blasting sites [38]. The occurrence of such changes were attributed to differing external conditions: the presence or lack of water in the boreholes, the hardness and brittleness of the rock strata and the presence of cracks and voids within these strata.

An interesting approach to optimising the performance of EEs in softer rocks is to employ air gaps within the explosive column loaded into the boreholes. It has been shown that with careful choice of the dimensions and distribution of such air gaps, the velocity of detonation is only slightly reduced, while allowing a noticeable reduction in the amount of EE loaded into the borehole [39]. That said, no information was presented as to whether the amount of mechanical work (i.e., volume of rock mined and the degree of fragmentation in the mined rock) has been adversely affected by the introduction of those air gaps and, if so, what the magnitude of the decline of the performance is.

The concept of critical diameter, that is, the lowest diameter of an energetic material charge that allows detonation to be sustained along its length, is well-known for energetic materials, including EEs [40]. Increasing the charge diameter above the critical diameter, however, can lead to increasing the performance of non-ideal energetic materials, such as



ammonium nitrate-based energetic materials and EEs. In the case of EEs, it was shown that their VoD is strongly dependent on charge diameter, particularly when the charge diameter is only slightly larger than the critical diameter for that EE formulation (Table 2) [41].

**Table 2.** Effect of charge diameter on the VoD of EEs [41]. Average VoD (n = 3) values are reported.

Charge Diameter [mm]	VoD [m/s]
<b>Emulinit 7L</b>	
32	-
40	3700 ± 40
50	3910 ± 30
<b>Emulinit 8L</b>	
32	3310 ± 170
40	3630 ± 30
50	3990 ± 55

### 5.2. Post-Detonation Gases

Energetic decomposition of EEs yields significant amounts of gaseous products, i.e., water vapour, carbon monoxide, carbon dioxide, nitrogen and nitrogen oxides. Among those, the emission of carbon monoxide and nitrogen oxides is seen as problematic, particularly in the case of underground blasting operations, due to the toxicity of those gases. The composition of post-detonation gases is a function of both the composition of the EE (as the oxidising agent to fuel ratio influences the carbon monoxide to carbon dioxide and nitrogen to nitrogen oxides ratios) as well as external circumstances (as cracks in the walls of the borehole or the presence of water within can lead to the occurrence of incomplete detonation) [39].

The composition of post-detonation gases can be altered by supplementing the EE formulation with additives intended to modify the energetic decomposition process. Such additives tend to be extremely varied in the existing literature, as they can fulfil the role of auxiliary oxidising agent, auxiliary fuel or act as catalysts.

The addition of aluminium and of ammonium nitrate to an EE formulation has recently been investigated in the context of their impact on the composition of post-detonation gases [42]. The interpretation of the results of this work, however, can be considered controversial, as the composition of the EE formulation was heavily modified to achieve a constant oxygen balance and those changes were not taken into account when reporting the amounts of post-detonation gases produced. This leads to obviously flawed conclusions, such as that supplementing the EE with an oxidising agent (ammonium nitrate prills) leads to an increased emission of carbon monoxide by a factor of 1.6–1.9, even though the ammonium-nitrate supplemented formulation contains a much greater share of carbon-based fuel than the initial EE formulation.

More recent research shows results contrary to the above, as supplementing the EE with a combination of ammonium nitrate and sodium perchlorate was found to decrease the amounts of carbon monoxide and nitrogen oxide present in the post-detonation gases (Table 3) [32]. Although supplementing EEs with oxidising agents did not resolve the issue of NO<sub>2</sub> emission, the lowered CO emission significantly decreases the risk associated with utilising such modified EE formulations in underground blasting operations.

In order to provide context for the above, it should be noted that exposure to 50 ppm of CO for approximately 30 min is considered non-threatening, whereas exposure to 200 ppm of CO concentration induces the first symptoms of carbon monoxide poisoning [43]. Although their toxicity is not as acute as in the case of CO, both nitric oxide (NO) and nitrogen dioxide (NO<sub>2</sub>) are also highly toxic and corrosive gases [44].

**Table 3.** Summary of the average composition of post-detonation gases for a commercial EE (Emulinit 8L) and EEs supplemented with additional oxidising agents (BK-1, BK-2). Reprinted from [32] under a CC BY license.

<b>Emulinit 8L</b>	<b>CO<sub>2</sub></b>	<b>CO</b>	<b>NO<sub>2</sub></b>	<b>NO</b>
Concentration [ppm]	4583 ± 45	162 ± 11	1.4 ± 0.2	20.0 ± 7.4
Unit mass emission [dm <sup>3</sup> /kg]	114.8 ± 1.1	4.11 ± 0.28	0.04 ± 0.01	0.51 ± 0.19
<b>BK-1</b>	<b>CO<sub>2</sub></b>	<b>CO</b>	<b>NO<sub>2</sub></b>	<b>NO</b>
Concentration [ppm]	4664 ± 6	100 ± 4	1.5 ± 0.2	11.6 ± 2.8
Unit mass emission [dm <sup>3</sup> /kg]	117.1 ± 0.9	2.51 ± 0.12	0.04 ± 0.01	0.29 ± 0.07
<b>BK-2</b>	<b>CO<sub>2</sub></b>	<b>CO</b>	<b>NO<sub>2</sub></b>	<b>NO</b>
Concentration [ppm]	4553 ± 24	136 ± 18	1.2 ± 0.2	11.0 ± 5.3
Unit mass emission [dm <sup>3</sup> /kg]	115.3 ± 0.4	3.45 ± 0.46	0.03 ± 0.01	0.28 ± 0.13

Predicting the properties of energetic materials based on their composition is an extremely difficult but worthwhile task, as it helps to minimise the exposure of personnel to those materials by reducing the number of experiments required to determine and fine-tune the properties of energetic materials being developed. Recently, a model for predicting the amount of post-detonation gases produced upon the detonation of ANFO- and EE-type energetic materials has been proposed [45]. Despite being an early model, an acceptable match to data reported in the literature was achieved.

## 6. Applications of EEs

EEs are commonly utilised in civilian blasting operations, particularly in mining. In this application, the use of bulk EEs is continuously increasing its market share (Figure 1) due to the increased safety parameters of those materials, as well as due to the ability to minimise the exposure of personnel to the threat of explosion than in the case of using traditional energetic materials [46].

The use of EEs in blasting operations associated with mining often encounters practical issues arising from the conditions existing in boreholes, both natural (e.g., temperature of the rock) and produced during the drilling of boreholes (e.g., presence of rock fragments in the borehole, cracking of borehole walls). In this regard, both the loading of boreholes and the reliability of detonation taking place across the entire length of the borehole are significant and common issues. The issue of loading boreholes is largely technical and requires careful control over the pressure and flow rate of the loaded EE.

Conversely, the reliability of detonation may easily be compromised, particularly in deep boreholes, due to the hydrostatic pressure exerted by the pillar of the EE. Depending on borehole depth, this pressure can be large enough to induce gas bubble compression in the bottom section of the borehole. This can be avoided by limiting borehole depth or resolved to some extent, by utilising a higher initiating stimulus. Another phenomenon that needs to be taken into account in regards to the reliability of detonation is the timing of detonations in neighbouring boreholes. When the blast wave caused by nearby detonation travels through a borehole containing EE, momentary compression of the gas bubbles present in the EE takes place, causing it to temporarily lose sensitivity to initiation. If this issue is not taken into account during the planning of blasting operations, it can even lead to misfires.

The use of EEs for testing the mechanical properties of construction materials is a non-obvious application that is of particular importance, both due to the relevance of data that can be acquired and due to the ever-present threat of bomb terrorism. In a recent work, the experimental testing of reinforced concrete was combined with a theoretical work-up, in order to yield a methodology for testing and modelling the fracture and resistance of brittle materials to blast loads [47]. In the given experimental case, the model was used to explain the role of the reinforcing material in limiting the propagation of cracks in the bulk

of the concrete, but other types of reinforced concrete materials have also been recently studied [48], providing an interesting insight for developing blast-resistant constructions. In this aspect, EEs have also been used to investigate the ability of pipelines to withstand blast loads [49].

Another non-straightforward application of EEs is in explosive welding. Compared to traditional welding methods, explosive welding allows a broader range of metals and alloys to be combined. In this approach, the use of EEs instead of traditional, high-performance energetic materials was found to allow welding even highly dissimilar materials (Figure 4), due to the lesser strain induced by the detonation of EEs [50,51], enabling the fabrication of a broader variety of composite materials.

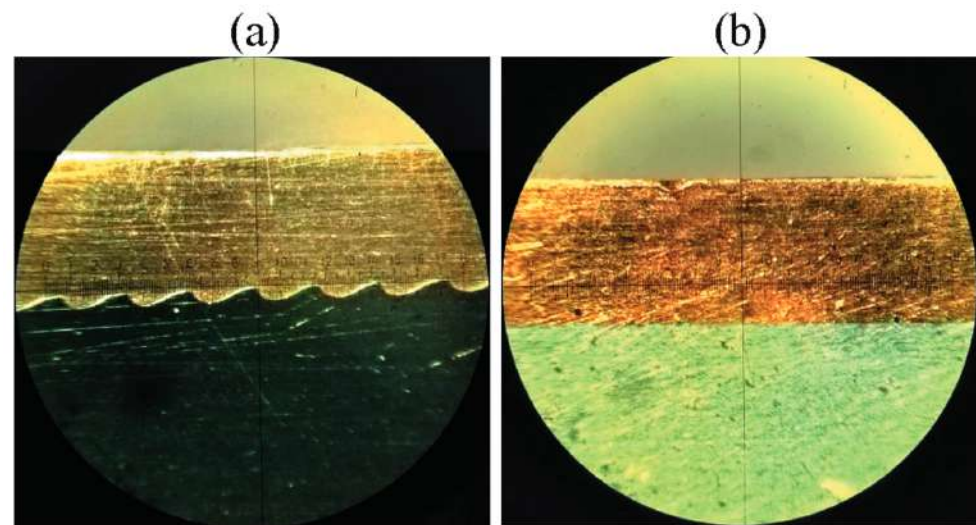

**Figure 4.** Cross-sections of (a) copper-steel and (b) copper-aluminium bonding zones produced via explosive welding with the use of EEs. Reprinted with the permission of Springer Nature from [51]. Copyright 2018.

The issue of water bodies, through which marine transport takes place, being covered with ice is important from an economical standpoint, particularly so in sub-polar and polar locations. One of the methods of removing such ice coverage is to employ energetic materials, due to their significant brisance. In the reported case, EEs were used for this purpose and a model of the behaviour of ice under blast loading was developed, potentially opening up a new avenue of application for these energetic materials [52].

Powder metallurgy is a relatively young field, dealing with the processing of metals from powders. In this field, energetic materials are frequently used as sources of mechanical work for compressing the processed powders into solid elements. The use of EEs for this purpose has been recently reported and even though metal powder solidification was readily achieved, the amount of used EE is relatively large, in the range of 500–1000 g for compressing approx. 60 g batches of iron powder [53]. Even though the method appears to be inefficient, it was found that the amount of EE used can be altered in order to tailor the hardness of the resultant solid elements, which is of some practical significance.

#### *Safety Considerations*

An important risk associated with conducting blasting operations is the occurrence of ground vibrations, often referred to as para-seismic oscillations. Such vibrations can propagate over long distances, damage and even topple buildings. Recently, a dynamic finite element model has been utilised to model these vibrations [54]. Although the proposed model predicted higher vibration magnitude than was experimentally observed, the predictions were fairly accurate over shorter distances. The observed inaccuracies were primarily attributed to the model not taking into consideration the occurrence of various

rock strata across the vibration propagation distance [55]. Even though the model needs to be refined significantly, it is a promising step forward in terms of predicting risks associated with conducting blasting operations.

An important consideration in terms of EE safety is their possible contamination. Among commonly encountered contaminants,  $\text{Fe}^{2+}$  ions have been found to lower the thermal decomposition temperature of EEs from approximately 280 °C to approximately 271 °C and to promote crystallisation in EE matrices [56].

## 7. Conclusions

Despite high entry requirements into the subject of EEs, the development of this class of energetic materials continues and appears to be attracting increasing research interest over recent years. This is due to both the significant improvements to the performance and the safety features of these materials, making them an increasingly more favourable alternative for traditional energetic materials in general and for nitroester-based energetic materials in particular.

The issues of the rheology and stability of both the EE matrices and the sensitised EEs have been a particular focus among recent works due to the practical considerations associated with the instruments and processes of sensitising and loading the EEs into boreholes. This aspect of EE development is also more readily available, as testing the rheology of even sensitised EEs does not necessitate conducting blasting operations and can be safely conducted in a specialised laboratory setting.

It should be noted, however, that the rheology of EEs ties in with the issue of the population and size distribution of pores in the sensitised EE. Despite multiple studies, the subject remains controversial and requires further experimental exploration. A particularly important question in this regard is that of the nature of the impact of the porosity parameters on the energetic performance and sensitivity of the EEs.

In contrast, the works dedicated to improving the energetic performance of EEs are significantly fewer, due to the extremely significant need to perform blasting repeatedly in a variety of experimental configurations, while ensuring the safety of both personnel and the utilised instruments. Even so, such works are highly valuable, both scientifically—pushing forward our understanding of the processes occurring in those energetic materials and the myriad factors influencing these processes—as well as economically, due to the fact that even a minute improvement in the performance of EEs translates into more efficient blasting operations, allowing more rock to be mined with a lesser total amount of energetic material utilised.

Among the above, particular attention should be paid to emerging additives to EE formulations, as the inclusion of even relatively common substances as additives was proven to significantly improve various properties of the EEs. This trend is expected to bring even further improvements to the properties and performance of EEs in the future, helping promote new, higher standards in the development and use of energetic materials.

The implementation of increasing standards for EEs inevitably involves discussion of the personnel health and environmental impacts of such materials. In this regard, the composition and amount of gases produced during the energetic decomposition of EEs is an essential, but under-explored issue. Although some strides have been made in limiting the emissions for EEs, the subject remains a significant issue, as current EE formulations produce carbon monoxide and nitrogen oxides in the post-detonation gases. Reducing these emissions remains an important, unresolved issue that needs to be overcome, in order to achieve “green” EEs.

**Author Contributions:** Conceptualization, B.K. and T.J.; Methodology, B.K., K.J. and T.J.; Validation, B.K., K.J. and T.J.; Investigation, K.S. (Krystyna Suda), P.K., K.S. (Kuba Swiatek); Data curation, K.S. (Krystyna Suda), P.K., K.S. (Kuba Swiatek), B.K.; Writing—original draft preparation, K.S. (Krystyna Suda), P.K., K.S. (Kuba Swiatek), B.K., K.J. and T.J.; Writing—review and editing, B.K., T.J. and K.J.; Visualization, K.S. (Krystyna Suda), P.K., K.S. (Kuba Swiatek), B.K. and T.J.; Supervision, B.K. and T.J.; Funding acquisition, T.J. and K.J. All authors have read and agreed to the published version of the manuscript.

**Funding:** T.J. acknowledges the scientific and innovative merit grant no. 04/040/RGJ22/0201 of the Rector of Silesian University of Technology. K.S., P.K. and K.Sw. acknowledge the support of the Silesian University of Technology “Research University—Excellence Initiative” program.

**Institutional Review Board Statement:** Not applicable.

**Informed Consent Statement:** Not applicable.

**Conflicts of Interest:** The authors declare no conflict of interest.

## References

1. Egly, R.S.; Neckar, A.E. Ammonium Nitrate-Containing Emulsion Sensitizers for Blasting Agents. U.S. Patent 3,161,551, 15 December 1964.
2. Bluhm, H.F. Ammonium Nitrate Emulsion Blasting Agent and Method of Preparing Same. U.S. Patent 3,447,978, 3 June 1969.
3. Tag, A.; Petterson, B.R.; Nygaard, E.C. Emulsion explosive. U.S. Patent 4,500,369, 19 February 1985.
4. Yates, D.E.; Dack, S.W. Emulsion Explosive Composition. U.S. Patent 4,710,248, 12 December 1987.
5. Chattopadhyay, A.K. Emulsion Explosive. U.S. Patent 5,500,062, 19 March 1996.
6. Hattori, K.; Fukatsu, Y.; Takahashi, M. Water-in-oil Emulsion Explosive Composition. U.S. Patent 4,326,900, 27 April 1982.
7. Nations, U. European Agreement Concerning the International Carriage of Dangerous Goods By Road (ADR). 2021. Available online: <https://unece.org/transportdangerous-goods/adr-2021-files> (accessed on 1 July 2022)
8. Kramarczyk, B.; Pytlik, M.; Mertuszka, P. Effect of aluminium additives on selected detonation parameters of a bulk emulsion explosive. *Materiały Wysokoenergetyczne* **2020**, *12*, 99–113. doi:10.22211/matwys/0197.
9. Zhao, H.R.; Wu, J.; Xu, M.x.; Zhang, K.m. Advances in the rheology of emulsion explosive. *J. Mol. Liq.* **2021**, *336*, 116854.
10. Nour, A.H. Emulsion types, stability mechanisms and rheology: A review. *Int. J. Innov. Res. Sci. Stud. (IJIRSS)* **2018**, *1*, 14–21.
11. Ravera, F.; Dziza, K.; Santini, E.; Cristofolini, L.; Liggieri, L. Emulsification and emulsion stability: The role of the interfacial properties. *Adv. Colloid Interface Sci.* **2021**, *288*, 102344.
12. Masalova, I.; Malkin, A.Y.; Ferg, E.; Kharatiyan, E.; Taylor, M.; Haldenwang, R. Evolution of rheological properties of highly concentrated emulsions with aging—Emulsion-to-suspension transition. *J. Rheol.* **2006**, *50*, 435–451.
13. Wang, Y.; Wang, X.G. Crystallization of interphase droplets in emulsion explosive matrices. *J. Dispers. Sci. Technol.* **2017**, *38*, 1483–1488.
14. Al-Sabagh, A.; Hussien, M.A.; Mishrif, M.R.; El-Tabey, A.E.; Elawady, A.A. Preparation and investigation of emulsion explosive matrix based on gas oil for mining process. *J. Mol. Liq.* **2017**, *238*, 198–207.
15. Zhou, J.; Wang, X.; Gong, M.; Zhao, M. The effect of surfactant on the rheology and stability properties of emulsion explosive matrices. *J. Dispers. Sci. Technol.* **2021**, 1–9. <https://doi.org/10.1080/01932691.2021.1924191>
16. Hirosaki, Y.; Murata, K.; Kato, Y.; Itoh, S. Detonation characteristics of emulsion explosive as function of void size and volume. In Proceedings of the 12th International Detonation Symposium, San Diego, CA, USA, 11–16 August 2002.
17. Van Ommeren, C.L. Emulsion Explosive Composition Containing Expanded Perlite. U.S. Patent 4,940,497, 10 July 1990.
18. Yunoshev, A.; Sil’Vestrov, V.; Plastinin, A.; Rafeichik, S. Influence of artificial pores on the detonation parameters of an emulsion explosive. *Combust. Explos. Shock Waves* **2017**, *53*, 205–210.
19. Mendes, R.; Ribeiro, J.; Plaksin, I.; Campos, J.; Tavares, B. Differences between the detonation behavior of emulsion explosives sensitized with glass or with polymeric micro-balloons. *J. Physics Conf. Ser.* **2014**, *500*, 052030.
20. Anshits, A.; Anshits, N.; Deribas, A.; Karakhanov, S.; Kasatkina, N.; Plastinin, A.; Reshetnyak, A.Y.; Sil’vestrov, V. Detonation velocity of emulsion explosives containing cenospheres. *Combust. Explos. Shock Waves* **2005**, *41*, 591–598.
21. Kramarczyk, B.; Mertuszka, P. Study of Influence of Sensitizer Content on Density of Bulk Emulsion Explosive Used in Underground Operations. *Cent. Eur. J. Energetic Mater* **2021**, *18*, 429–447.
22. da Silva, G.; Dlugogorski, B.Z.; Kennedy, E.M. Water-in-oil emulsion foaming by thiourea nitrosation: Reaction and mass transfer. *AIChE J.* **2006**, *52*, 1558–1565.
23. Cranney, D.H.; Hansen, J.R. Gassed Emulsion Explosive. U.S. Patent 6,022,428, 8 February 2000.
24. Cordova, P.F.P.; Lopez, L.A.C. Low Density Explosive Emulsion. U.S. Patent 8,187,397, 29 May 2012.
25. Pienaar, A.; Yakhoub, H.; Kennedy, E.; Dlugogorski, B. Emulsion Explosive Sensitising. U.S. Patent App. 14/003,450, 3 April 2014.
26. Peyrot, L.; Duriche, C.; Elkhatib, M.; Delalu, H. Elaboration of high-grade chloramine from ternary and quaternary ammoniacal combinations and hypochlorite at 100 chlorometric degrees. *J. Chem. Res. Synopses* **1999**, *6*, 358–359.

27. Venpin, W.K.; Kennedy, E.M.; Mackie, J.C.; Dlugogorski, B.Z. Trapping of nitric oxide, generated during sensitization of ammonium nitrate emulsion explosive, by aromatic nitroso sulfonates. *Ind. Eng. Chem. Res.* **2013**, *52*, 10561–10568.
28. Maranda, A.; Paszula, J.; Zawadzka-Małota, I.; Kuczyńska, B.; Witkowski, W.; Nikolczuk, K.; Wilk, Z. Aluminum powder influence on ANFO detonation parameters. *Cent. Eur. J. Energetic Mater.* **2011**, *8*, 279–292.
29. Yue, G.; He, J.; Wang, X.G.; Yan, S.L.; Cheng, Y.F. Influence of Titanium Powder on Detonation Performances and Thermal Decomposition Characteristics of Emulsion Explosive. *Chin. J. Energetic Mater.* **2017**, *25*, 304–308.
30. Wang, Y.; Ma, H.; Shen, Z.; Wang, B.; Xue, B.; Ren, L. Detonation characteristics of emulsion explosives sensitized by hydrogen-storage glass microballoons. *Propellants Explos. Pyrotech.* **2018**, *43*, 939–947.
31. Cheng, Y.F.; Meng, X.R.; Feng, C.T.; Wang, Q.; Wu, S.S.; Ma, H.H.; Shen, Z.W. The effect of the hydrogen containing material TiH<sub>2</sub> on the detonation characteristics of emulsion explosives. *Propellants Explos. Pyrotech.* **2017**, *42*, 585–591.
32. Kramarczyk, B.; Pytlik, M.; Mertuszka, P.; Jaszcz, K.; Jarosz, T. Novel Sensitizing Agent Formulation for Bulk Emulsion Explosives with Improved Energetic Parameters. *Materials* **2022**, *15*, 900.
33. Mishra, A.K.; Rout, M.; Singh, D.R.; Jana, S.P. Influence of gassing agent and density on detonation velocity of bulk emulsion explosives. *Geotech. Geol. Eng.* **2018**, *36*, 89–94.
34. Mertuszka, P.; Fuławka, K.; Pytlik, M.; Szastok, M. The influence of temperature on the detonation velocity of selected emulsion explosives. *J. Energetic Mater.* **2020**, *38*, 336–347.
35. Mertuszka, P.; Fuławka, K.; Pytlik, M.; Wincenciak, J.; Wawryszewicz, A. The influence of time on the density and detonation velocity of bulk emulsion explosives—A case study from Polish copper mines. *Cent. Eur. J. Energetic Mater.* **2019**, *16*, 245–258.
36. PRADHAN, M. Sleep time: Its consequences on performance of bulk emulsion explosive. *J. Sci. Ind. Res.* **2010**, *69*, 125–128.
37. Mertuszka, P.; Kramarczyk, B. The impact of time on the detonation capacity of bulk emulsion explosives based on Emulinit 8L. *Propellants Explos. Pyrotech.* **2018**, *43*, 799–804.
38. Agrawal, H.; Mishra, A.K. A study on influence of density and viscosity of emulsion explosive on its detonation velocity. *Model Meas Control C* **2018**, *78*, 316–336.
39. Balakrishnan, V.; Pradhan, M.; Dhekne, P. Field investigation in the detonation behavior of emulsion explosive column induced with air gaps. *Min. Sci.* **2019**, *26*, 55–68.
40. Sil'vestrov, V.; Plastinin, A.; Karakhanov, S.; Zykov, V. Critical diameter and critical thickness of an emulsion explosive. *Combust. Explos. Shock Waves* **2008**, *44*, 354–359.
41. Mertuszka, P.; Cenian, B.; Kramarczyk, B.; Pytel, W. Influence of explosive charge diameter on the detonation velocity based on Emulinit 7L and 8L bulk emulsion explosives. *Cent. Eur. J. Energetic Mater.* **2018**, *15*, 351–363.
42. Nyberg, U.; Klippmark, V.; Karlström, H.; Beyglou, A.; Petropoulos, N. *Short Time Measurements of Toxic Fumes from Detonation of Emulsion Explosive: Initial Tests in Blast Chamber*; Swedish Blasting Research Centre och Luleå Tekniska Universitet: Luleå, Sweden 2015.
43. Mahajan, S.; Jagtap, S. Metal-oxide semiconductors for carbon monoxide (CO) gas sensing: A review. *Appl. Mater. Today* **2020**, *18*, 100483.
44. Brunelli, L.; Crow, J.P.; Beckman, J.S. The comparative toxicity of nitric oxide and peroxydinitrite to Escherichia coli. *Arch. Biochem. Biophys.* **1995**, *316*, 327–334.
45. Suceška, M.; Tumara, B.S.; Skrllec, V.; Stankovic, S. Prediction of concentration of toxic gases produced by detonation of commercial explosives by thermochemical equilibrium calculations. *Def. Technol.* **2021**. <https://doi.org/10.1016/j.dt.2021.10.011>.
46. Lyashenko, V.; Vorob'ev, A.; Nebohin, V.; Vorob'ev, K. Improving the efficiency of blasting operations in mines with the help of emulsion explosives. *Min. Miner. Depos.* **2018**, *12*, 95–102.
47. Pham, D.H.; Le, B.D.; Nguyen, C.T.; Tran, H.T. Modeling the fracture behavior of Ultra-High Performance Fiber Reinforced Concrete slabs under contact Blast Loading. *IOP Conf. Ser. Mater. Sci. Eng.* **2020**, *869*, 052079.
48. Nam, J.; Kim, H.; Kim, G. Experimental investigation on the blast resistance of fiber-reinforced cementitious composite panels subjected to contact explosions. *Int. J. Concr. Struct. Mater.* **2017**, *11*, 29–43.
49. Tang, Q.; Jiang, N.; Yao, Y.; Zhou, C.; Luo, X.; Wu, T. Safety assessment of buried gas pipeline subject to surface explosion: A case study in Wuhan, China. *Eng. Fail. Anal.* **2021**, *120*, 105119.
50. Zlobin, B.; Silvestrov, V.; Shtertser, A.; Plastinin, A.; Kiselev, V. Enhancement of explosive welding possibilities by the use of emulsion explosive. *Arch. Metall. Mater.* **2014**, *59*, 1587–1592.
51. Zlobin, B.; Kiselev, V.; Shterzer, A.; Plastinin, A. Use of emulsion explosives in experimental studies of flows in the bonding zone in explosive welding. *Combust. Explos. Shock Waves* **2018**, *54*, 231–237.
52. Bogomolov, G.N.; Glazyrin, V.P.; Orlov, M.Y. Research destruction ice under dynamic loading. Part 1. Modeling explosive ice cover into account the temperature. In *MATEC Web of Conferences*; EDP Sciences: Les Ulis, France 2015; Volume 110, p. 01014.
53. Azmi, N.A.; Hilmi, A.H.; Yusof, M.A.; Ismail, A. Characteristics of Iron powder when Pressed using Explosive Pressing method. In *IOP Conference Series: Materials Science and Engineering*; IOP Publishing: Bristol, UK 2015; Volume 429, p. 012095.
54. Ainalis, D.; Kaufmann, O.; Tshibangu, J.P.; Verlinden, O.; Kouroussis, G. Modelling the source of blasting for the numerical simulation of blast-induced ground vibrations: A review. *Rock Mech. Rock Eng.* **2017**, *50*, 171–193.

- 
55. Kumar, S.; Mishra, A.; Choudhary, B.; Sinha, R.; Deepak, D.; Agrawal, H. Prediction of ground vibration induced due to single hole blast using explicit dynamics. *Mining Metall. Explor.* **2020**, *37*, 733–741.
  56. Xie, X.H.; Feng, Y.Q.; Liu, S.H.; Zhu, J. Thermal behavior and stability of emulsion explosives in the presence of ferrous ion. *J. Therm. Anal. Calorim.* **2020**, *139*, 999–1006.

# The Impact of Time on the Detonation Capacity of Bulk Emulsion Explosives based on Emulinit 8L

Piotr Mertuszka<sup>\*[a]</sup> and Bartłomiej Kramarczyk<sup>[b]</sup>

**Abstract:** One of the elements of enhanced safety of mechanically loaded emulsion explosives is the loss of its explosive properties after a certain period of time, without reference to the particular research. The manufacturer described this time for approximately 48 hours from the time of its charging to the blasting holes with a gas sensitized product. Under regular conditions of mining works, this time is absolutely sufficient for safe mining operations. In practice, some unforeseeable situations may occur that the charged explosive is not fired within the prescribed period

of time. The aim of the study was to verify the knowledge regarding the behavior of mechanically loaded emulsion explosives used in Polish underground copper mines by tracking the changes of detonation velocity over time. The subject of research was Emulinit 8L emulsion explosive manufactured by NITROERG from Bieruń, Poland. The measurements were provided using a MicroTrap™ VOD/Data Recorder, which allows for continuous measurement of the detonation velocity of explosives.

**Keywords:** blasting works · emulsion explosives · velocity of detonation · VOD

## 1 Introduction

Years of research work on more efficient and safer explosives led to the creation of emulsion explosives which offer a good alternative to ANFO and dynamites. Their advantage lies, among others, in excellent resistance to water and low gas emissions [1]. Charging of the blast holes with emulsion is almost completely automated, which increases effectiveness, comfort and security of blasting works. The very first industrial application of bulk emulsion explosives in underground Polish copper mines belonging to KGHM were conducted in 1997 in “Rudna” mine. However, the method was abandoned due to excessive explosive density and restarted again at the end of 2002. In 2004, almost 10% of explosives used in the “Rudna” mine was charged by the use of prototype of a blasting utility vehicle with an integral bulk emulsion module [2]. In the following years, an increase in the use of bulk explosives in terms of the total kilograms of explosives used, which is shown in Figure 1. In previous years, as much as 80% of all explosives used in KGHM’s mines have been bulk emulsion explosives.

One of the basic parameters describing the explosives properties in the classic Chapman-Jouguet theory is detonation velocity, which can be defined as the speed of propagation of the chemical reaction zone and the related shock wave through a detonated explosive [3,4]. During the practical use of the bulk emulsion explosives, a number of questions appeared concerning the variability of its parameters over the time from loading of the blast holes until the time of firing [5]. Bearing in mind that the addition of “hot spots” enhance the rapid explosive combustion of the emulsion. It was assumed that the bulk emulsion explosives loses deto-

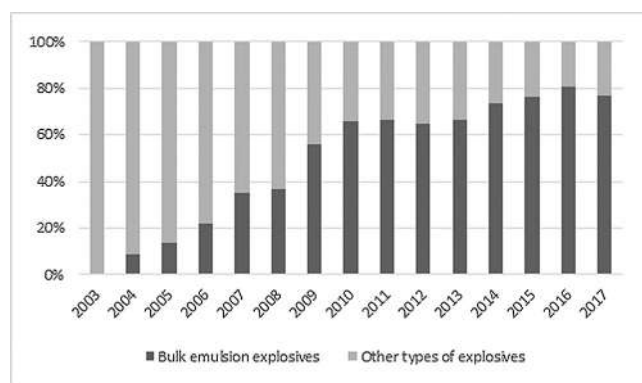

**Figure 1.** Percentage of the bulk emulsion explosives in relation to total explosives used in “Rudna” mine between 2004 and 2017.

nation capacity after a period of time [6]. The sleep time for emulsion explosive is approximately 48 hours, while full detonation capacity is being reached approximately 30 minutes after being into the blast holes [7]. This means that an explosive should be initiated in a specified time period to achieve proper detonation in the blasting works. In practice, manufacturers do not specify the period in which bulk explosives should be fired, but only a range of optimal den-

[a] P. Mertuszka  
KGHM CUPRUM Ltd. Research & Development Centre,  
2–8 Sikorskiego Street, 53-659 Wrocław, Poland  
\*e-mail: pmertuszka@cuprum.wroc.pl

[b] B. Kramarczyk  
NITROERG S.A., 1 Nobla square, 43-150 Bieruń, Poland



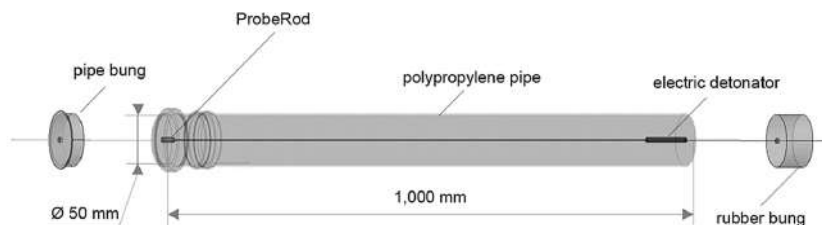

**Figure 2.** Scheme of installation of the ProbeRod and detonator in polypropylene pipe.

sities. To achieve a high quality of product for the blasting works when using the Emulinit 8L, its density should be between  $0.80 \text{ g/cm}^3$  and  $1.25 \text{ g/cm}^3$ . The following paper presents the results revealing the impact of time on the detonation velocity based on Emulinit 8L bulk emulsion explosive.

## 2 Materials and Methods

The research consisted of firing of previously prepared emulsion explosive samples in specified intervals of time and measuring their detonation velocity. The explosive samples were prepared by filling polypropylene sewage pipes with an external diameter of 50 mm, length of 1,000 mm with a wall thickness of 1.8 mm with the explosive (Figure 2). This is typical diameter of the blast holes used in underground Polish copper mines. Samples were equipped with MREL's VOD ProbeRod with a unit resistance of  $331.7 \text{ ohm/m}$  and fired using an instantaneous electrical detonator. Measurements were conducted using a MicroTrap™ VOD/Data Recorder allowing for the continuous measurement of the detonation velocity of explosives with a high resolution at up to 2 MHz [8].

The pipes were filled with the gas sensitized emulsion explosive and allowed to expand. The excess amount to overflow the pipe was removed. The aim was to make the explosive as homogeneous as possible by removing the voids that were created while charging of the samples. After the pipes were filled with sensitized emulsion, they were plugged and transported to the firing site in a horizontal position. The remaining samples were stored horizontally in explosives depot with a constant ambient temperature of approximately 15 degrees Celsius. The average weight of each prepared sample was approximately 2.2 kg. Prior to the detonation of each sample they were covered with a 50 cm layer of sand for noise requirements.

The research was conducted in the NITROERG company test site in Bieruń, Poland. The subject of research was Emulinit 8L bulk emulsion explosive, which was loaded from the blasting utility vehicle equipped with pumping module. Selected parameters of tested explosive are shown in Table 1.

The VOD ProbeRod is inserted axially in the sample of explosive from the opposite end of the detonator. Then the ProbeRod is connected to the coaxial cable to transmit the

**Table 1.** Selected parameters of Emulinit 8L explosive (based on manufacturer's data).

Critical diameter	34 mm
Minimal diameter of the blast holes	34 mm
Velocity of detonation	3,800 m/s
Oxygen balance	0.05 %
Sensitivity to friction	> 360 N
Sensitivity to impact	> 30 J
Heat of explosion	3,084 kJ/kg
Concentration of energy	3,456 kJ/dm <sup>3</sup>
Specific energy	788 kJ/kg
Specific volume of gaseous products of explosion	870 dm <sup>3</sup> /kg

signal to a MicroTrap™ VOD/Data Recorder. Once the connection was checked, the instrument was placed in a safe distance away from the detonation area and left in monitoring mode.

## 3 Experimental Section

The detonation velocity of the prepared explosive charges is measured in 14 selected intervals after loading. Table 2 shows the intervals values and the results as they range from 30 minutes to 6 months. Figure 3 is a graphical representation of the data shown in Table 2. To obtain the average results, each series of the test consisted of three samples. The time interval of each test series did not exceed 5 minutes.

The VOD measurements have proven that the detonation parameters of the considered explosive changed over time. The highest detonation velocity was observed for the first explosive sample fired 30 minutes after loading into the plastic pipe. The other samples in the first series has a slight decrease in detonation velocity (2 to 5%) in respect to the first sample was noted. The drop in detonation velocity within first series was due to operational break between individual samples that was required to prepare the next samples. This includes the inserting of the ProbeRod and detonator, placing of the samples in the firing pit and covering with sand. The consecutive measurement series show an exponential decrease in detonation velocity in relation to the first tests.

Examples of VOD graphs (distance versus time) for selected tests are shown in Figures 4 and 5. The slope of the

**Table 2.** Results of VOD tests of Emulinit 8L bulk emulsion explosive.

Series No.	Time	Velocity of detonation [m/s]			Average
		Sample #1	Sample #2	Sample #3	
1	30 min.	4,345	4,210	4,135	4,230 ± 105
2	60 min.	3,958	3,975	4,055	4,005 ± 40
3	90 min.	3,910	3,905	3,895	3,903 ± 7.5
4	180 min.	3,745	3,745	3,705	3,732 ± 20
5	240 min.	3,670	3,665	3,650	3,662 ± 10
6	300 min.	3,590	3,620	3,580	3,597 ± 20
7	24 hrs.	3,510	3,565	3,555	3,543 ± 27.5
8	48 hrs.	3,450	3,385	3,425	3,420 ± 32.5
9	7 days	3,370	3,290	3,330	3,330 ± 40
10	14 days	3,180	3,130	3,150	3,153 ± 25
11	31 days	3,085	3,105	3,110	3,100 ± 12.5
12	72 days	3,060	3,045	3,055	3,053 ± 7.5
13	4 months	3,000	3,030	3,020	3,017 ± 15
14	6 months	2,905	2,905 <sup>[a]</sup>	2,955	2,930 ± 25

[a] Detonation with booster.

graphs at any position is the detonation velocity of the explosive at that particular position. As shown in the following graphs, the measurement of detonation velocity was recorded along the entire length of the explosive charges. The considered explosive has reached the stable detonation velocity a few centimeters away from the position of detonator. Statistical dispersion of recorded VOD values within given series did not exceed 1%, with the maximum deviation for the first series of 2%.

The detonation capacity of bulk emulsion explosives depends primarily on the proper sensitization of the matrix [9]. As mentioned previously, formation of the “hot spots” is closely linked to the density of emulsion explosives. In fact, bulk emulsions below a certain density do not detonate. Increasing density leads to increasing detonation velocity up

towards critical density at which the end product loses the detonation capacity [10]. The density of bulk emulsion explosive may be measured in mining conditions in a simple way by the operator of blasting utility vehicle. For the purposes of the presented analysis, three samples for density measurements were prepared at the same time as explosive’s charges to determine the correlation between the detonation velocity of the bulk explosive and its density. The density of explosive was measured with an electronic scale with an accuracy of 1 g and with disposable 500 cm<sup>3</sup> cups. The cups were filled with explosive from pumping module of blasting utility vehicle. The emulsion is leveled with the top edge of the cup. The cup with explosive was then weighed. While the gassing process occurred, at specific time intervals, excess of explosives was removed by leveling and weighed (Figure 6).

The density was determined by dividing the weight of the emulsion by volume of the cup. An empty cup weighed 9 grams. The results are shown in Table 3. To determine the correlation between density and detonation velocity of bulk emulsion, researchers applied the Pearson product-moment correlation coefficient used to measure the strength of a linear association between two variables [11]. The strength of the correlation influences to what degree the records behave as it is supposed to, that is assuming that  $r_{xy} > 0$ , when density increases, detonation velocity is increasing too. When  $r_{xy}$  amounts to, for example 0.4, then it means, that only some of data follows the dependence (the trend is visible, however some deviations may appear). If  $r_{xy}$  is close to 1, then almost all records meet the assumptions and trend is clearly visible. Variables used for analysis of the correlation are shown in Table 4.

As the definition states, the correlation between variables X and Y is a strength measure of linear dependence between the variables. The Pearson product-moment correlation coefficient is calculated as follows:

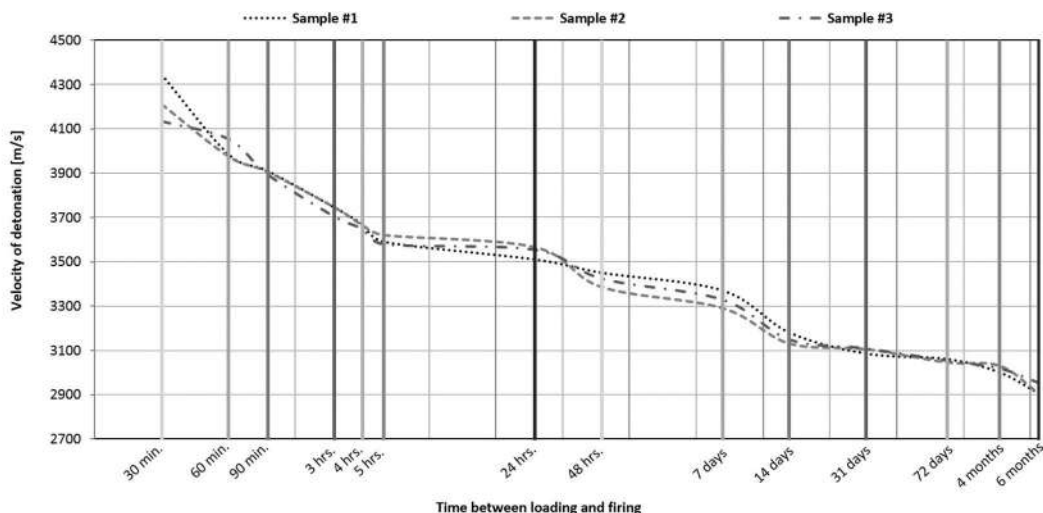

**Figure 3.** Graph of detonation velocity changes of Emulinit 8L samples over time.

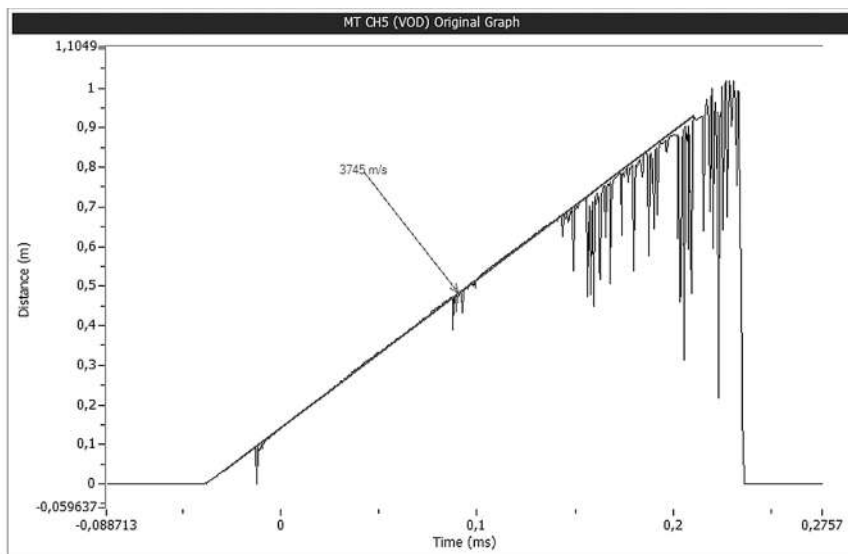

Figure 4. VOD plot of Emulinit 8L sample tested 180 minutes after loading (test #1).

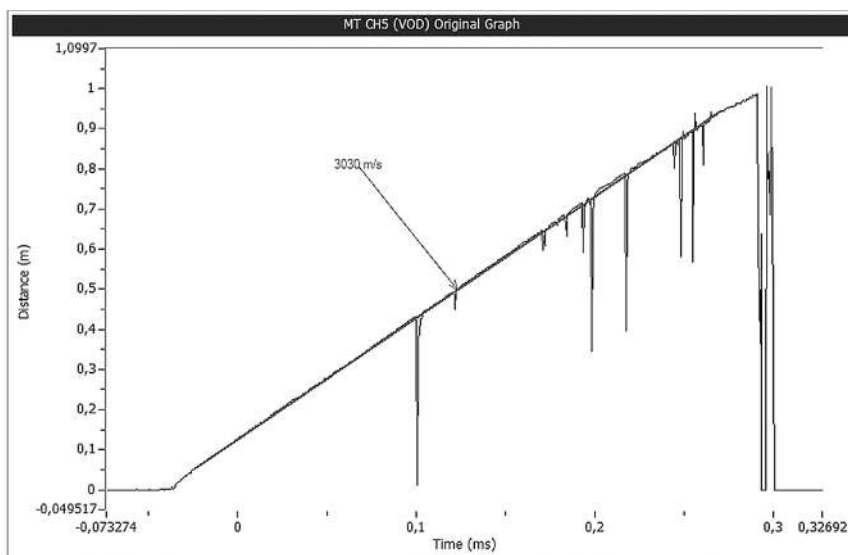

Figure 5. VOD plot of Emulinit 8L sample tested 4 months after loading (test #2).



Figure 6. View of the cup after loading (left) and while gassing process (right).

$$r_{xy} = \frac{\sum(X_i - \bar{X})(Y_i - \bar{Y})}{\sqrt{[\sum(X_i - \bar{X})^2][\sum(Y_i - \bar{Y})^2]}} = \frac{1}{n-1} \frac{\sum(X_i Y_i - \bar{X}\bar{Y})}{\sigma_x \times \sigma_y}$$

where:

- $r_{xy}$  Pearson product-moment correlation coefficient,
- $X_i, Y_i$   $i$ -th values observed in the X and Y datasets,
- $\bar{X}, \bar{Y}$  the mean of X and Y datasets,
- $\sigma_x, \sigma_y$  standard deviation of datasets X and Y,
- $n$  number of observations (same for X and Y).

Using the Pearson correlation coefficient calculator, the coefficient  $r$  amounts to 0.998 (significance less than 0.001),

**Table 3.** Results of density measurements of Emulinit 8L.

No. of test	Time [min.]	Density [g/cm <sup>3</sup> ]			Average
		Sample #1	Sample #2	Sample #3	
1	0	1.34	1.35	1.33	1.34
2	10	1.30	1.29	1.29	1.29
3	20	1.26	1.27	1.26	1.26
4	30	1.23	1.24	1.22	1.23
5	50	1.19	1.19	1.19	1.19
6	60	1.19	1.17	1.17	1.18
7	70	1.17	1.17	1.15	1.17
8	90	1.17	1.15	1.14	1.15
9	140	1.13	1.13	1.12	1.12
10	180	1.12	1.12	1.12	1.12
11	240	1.11	1.10	1.09	1.10
12	300	1.09	1.09	1.07	1.08

**Table 4.** Variables used in correlation analysis.

No. of test	Time [min.]	Average density	Average VOD
		(variable X) [g/cm <sup>3</sup> ]	(variable Y) [m/s]
1	30	1.23	4,230
2	60	1.18	4,005
3	90	1.15	3,903
4	180	1.12	3,732
5	240	1.10	3,662
6	300	1.08	3,597

which can be interpreted as a very strong and almost perfect correlation between density and detonation velocity of explosive in a period from 30 minutes to 5 hours. The correlation here is a positive one, i.e. when the density of bulk emulsion explosive decreases, so does its detonation velocity.

## 4 Results and Discussion

Years of work on more efficient, safer and cheaper explosives led to the creation of so-called third generation explosives, i.e. bulk emulsion explosives, which are mechanically loaded into the blast holes. In previous years, as much as 80% of all explosives used in Polish copper mines belonging to KGHM (the biggest national consumer of explosives and blasting agents) were represented by bulk emulsion explosives. They achieve full detonation capacity approximately 30 minutes after being loaded into the blast holes. For technological and organizational reasons, the time elapsed between loading and firing of the mining faces in KGHM's mines conditions varies between 30 minutes and 10 hours. In specific cases, however, this time may be extended up to 48 hours. This situation might happen when the blasting works are focused on destressing blasting that may release the seismic energy accumulated in the rock-mass. This research has shown that the deto-

nation velocity of Emulinit 8L reduces over a period of 24 hours after loading. This reflects that the brisance has fallen every hour. To maximize the effectiveness of the used explosives, mining faces should be fired as fast after loading as possible. Table 2 shows that the detonation velocity of the samples detonated 5 hours after loading (series 6) decreased by 15% in comparison with the first sample (series 1). This issue should be further studied in detail as detonation velocity is one of the main factors affecting the efficient advance and progress of mining works. To maintain the stability of the manufactured in situ bulk emulsion explosive, sensitizing parameters need to be selected so that the obtained material reaches stable detonation velocity within the specified time period. This would necessitate taking into consideration other factors influencing the changes of density and detonation velocity such as the composition of the emulsion matrix, the amount of added sensitizer or temperature.

## 5 Conclusions

Research findings on the impact of time on detonation velocity as a parameter describing the detonation process of an explosive, developed within the framework of this paper have proved that this parameter is highly variable over time, especially within the first few hours after loading. It affects directly the effectiveness of blasting works. Presumably, not all of the mining faces are fired in an interval that is optimal for this type of explosive, which may result in smaller face advance. The issue is of major importance in the case of destressing blasting of group of mining faces, which are loaded by several consecutive crews and fired a day or even two days after loading of the first mining face was done. The detonation velocity of considered Emulinit 8L bulk emulsion explosive is stabilizing after about 48 hours and its detonation capacity is maintained for at least 6 months.

It should be also noted that not only time influences the behavior of the bulk emulsions in given mining conditions. One may expect that other factors include the temperature of the rock-mass, diameter of the blast hole, and the amount of sensitizer used may influence the firing process as well. Comprehensive knowledge on the influence of other factors on the detonation velocity of bulk emulsion explosives may allow to define the rules of optimal use of selected explosive in given mining conditions. This may prove that modification of gassing process of considered emulsion would be required. It can be reached by changing the sensitizer composition or dosing of this component. Additionally, the results of research performed allow to reject the thesis, that the considered bulk emulsion explosive loses its detonation capacity after approximately 48 hours after loading. Almost the same behavior has been observed for RP-T2 bulk emulsion manufactured by Maxam, which is also widely used in Polish underground copper mines conditions.

## Acknowledgements

This research was supported by Polish Ministry of Science and Higher Education of Republic of Poland. The authors would like to thank the management of NITROERG S.A. for providing necessary facilities and assistance during the field investigations. Special thanks to Bogusław Cenian whom helped intensively in the field work. Unfortunately he passed shortly after completion of presented research.

## References

- [1] X. Wang, Emulsion Explosives, *Metallurgical Industry Press*, Beijing, **1994**.
- [2] S. Laskownicki, Z. Maćkowiak, B. Gołąbek, J. Kasperski, Mechanizacja robót strzałowych w zakładach górniczych KGHM Polska Miedź S. A. z zastosowaniem materiałów wybuchowych emulsyjnych luzem [Mechanization of blasting works in the KGHM Polska Miedź SA mine employing bulk explosives], *Górnictwo i Geoinżynieria* **2004**, *28*, 219–230.
- [3] Y. V. Alymova, V. É. Annikova, N. Y. Vlasova, B. N. Kondrikov, Detonation Characteristics of Emulsion Explosives, *Combust. Explos. Shock Waves (Engl. Transl.)* **1994**, *30*, 340–345.
- [4] J. Lee, P. A. Persson, Detonation Behavior of Emulsion Explosives, *Propellants Explos. Pyrotech.* **1990**, *15*, 208–2016.
- [5] H. S. Venkatesh, G. R. Adhikari, A. I. Theresraj, Variability in Velocity of Detonation of Commercial Explosives as Measured in Field Trials, *Min. Technol.* **2008**, *117*, 6–11.
- [6] M. Pradhan, Sleep Time: Its Consequences on Performance of Bulk Emulsion Explosive, *J. Sci. Ind. Res.*, **2010**, *69*, 125–128.
- [7] B. Zygmunt, A. Maranda, D. Buczkowski, *Materiały wybuchowe trzeciej generacji [Third generation explosives]*, Warszawa, Poland: Wojskowa Akademia Techniczna, **2007**.
- [8] J. Mesec, S. Žganec, I. Kovač, In-hole Velocity of Detonation (VOD) Measurements as a Framework for the Selection Type of Explosive, *Int. J. Min. Sci. Technol.* **2015**, *25*, 675–680.
- [9] A. K. Mishra, M. Rout, D. R. Singh, S. P. Jana, Influence of Gassing Agent and Density on Detonation Velocity of Bulk Emulsion Explosives, *Geotech. Geol. Eng.* **2017**, doi.org/10.1007/s10706-017-0308-7.
- [10] V. V. Sil'vestrov, Density Dependence of Detonation Velocity for Some Explosives, *Combust. Explos. Shock Waves (Engl. Transl.)* **2006**, *42/4*, 472–479.
- [11] K. Pearson, *Early Statistical Papers*, Cambridge, England: University Press, **1948**.

Received: February 22, 2018  
Published online: ■■■, ■■■■

## FULL PAPER

---



*P. Mertuszka\*, B. Kramarczyk*

1 – 7

**The Impact of Time on the Detonation Capacity of Bulk Emulsion Explosives based on Emulinit 8L**

---

This article is available in PDF-format, in colour, at:  
[http://www.wydawnictwa.ipo.waw.pl/materialy-wysokoenergetyczne/materialy-wysokoenergetyczne12/2/HEM\\_0197.pdf](http://www.wydawnictwa.ipo.waw.pl/materialy-wysokoenergetyczne/materialy-wysokoenergetyczne12/2/HEM_0197.pdf)

*Materiały Wysokoenergetyczne / High Energy Materials*, 2020, 12 (2), 99 – 113; DOI 10.22211/matwys/0197  
 ISSN 2083-0165

Copyright © 2020 Lukaszewicz Research Network - Institute of Industrial Organic Chemistry, Poland



Article is available under the Creative Commons Attribution-NonCommercial-NoDerivs 3.0 license CC BY-NC-ND 3.0.

## Research paper / Praca doświadczalna

# Effect of aluminium additives on selected detonation parameters of a bulk emulsion explosive Wpływ dodatku aluminium na wybrane parametry detonacyjne materiału wybuchowego emulsyjnego luzem

Bartłomiej Kramarczyk<sup>1)</sup>, Mateusz Pytlik<sup>2)</sup>, Piotr Mertuszka<sup>3,\*)</sup>

<sup>1)</sup> NITROERG S.A., Plac A. Nobla 1, 43-150 Bieruń, Poland

<sup>2)</sup> Central Mining Institute, Plac Gwarków 1, 40-166 Katowice, Poland

<sup>3)</sup> KGHM CUPRUM Ltd. Research and Development Centre, 2-8 Sikorskiego Street, 53-659 Wrocław, Poland

\* E-mail: pmertuszka@cuprum.wroc.pl

**Abstract:** The article presents an assessment of the influence of aluminium granules content on selected detonation parameters of a chemically sensitised bulk emulsion explosive. The analysis covered determination of relative explosive strength using a ballistic mortar and Trauzl blocks, free field air blast tests and detonation velocity measurements. Five types of emulsion explosives with differing aluminium content were tested at loadings of 0, 1, 3, 5 and 7%.

**Streszczenie:** W artykule dokonano oceny wpływu zawartości dodatku pyłu aluminiowego na wybrane parametry detonacyjne materiału wybuchowego emulsyjnego luzem uczulanego chemicznie. Analiza zawierała oznaczenie zdolności do wykonania pracy na wahadle balistycznym i w blokach ołowianych, pomiar ciśnienia fali podmuchu oraz pomiar prędkości detonacji. Do badań zastosowano pięć typów materiału wybuchowego emulsyjnego różniących się procentową zawartością aluminium, tj. 0, 1, 3, 5 i 7%.

**Keywords:** emulsion explosives, aluminium granules, detonation parameters

**Słowa kluczowe:** materiały wybuchowe emulsyjne, aluminium granulowane, parametry detonacyjne

## 1. Introduction

The discovery of emulsion explosives dates back to 1969, when Harold Frederick Bluhm from Atlas Chemical Industries patented a water-in-oil emulsion explosive [1]. Today, over 50 years after his discovery, emulsion explosives are commonly used for rock extraction in both underground and surface mines, as well as in civil engineering, tunneling and demolition. According to a Future Market Insights research study [2], the global sales volume of emulsion explosives is projected to reach 13 million tonnes by the end of the decade. A water-in-oil emulsion matrix composition, comprising of an oxidiser and oil, is not capable of detonation. The inorganic phase consists of supersaturated oxidiser solutions such as:

- ammonium nitrate(V),
- calcium nitrate(V), or
- sodium nitrate(V),

whereas the organic phase consists of fuels, such as mineral oil with waxes added. The remaining components are:

- water,
- emulsifiers,
- sensitisers, and
- physico-chemical property modifiers.

In order to enhance the heat of explosion and increase the pressure of the gaseous products, additional solid fuels such as aluminium, are also utilised.

Aluminium is also widely used as an additive in other explosives, including high explosives, pyrotechnic products and rocket propellants [3]. This is aimed at increasing the reaction temperature, and thereby the pressure of the gaseous products. However, the addition of aluminium does not always lead to an improvement in all the thermodynamic parameters. Depending on the type of explosives, the addition of aluminium can either improve or worsen detonation parameters. In the case of ANFO, the addition of aluminium leads to a considerable improvement in detonation parameters. Increasing the aluminium content is associated with an increase in reaction temperature and detonation velocity with a simultaneous decrease in toxic detonation products. Furthermore, it leads to an increased relative explosive strength and air blast pressure. It also increases the sensitivity of ANFO to stimuli. Therefore, the addition of aluminium in this case is very beneficial [4-6].

In turn, addition of aluminium has a somewhat different effect on the detonation of high explosives of pure chemical compounds such as nitro compounds, organic nitrates or nitroamines. Chemical compounds in the form of molecules containing both fuel (primarily carbon) and oxygen, which react exothermically during detonation, are mainly characterised by a negative or close to zero oxygen balance. During detonation, aluminium consumes the oxygen required for combusting carbon originating from the decomposition of an explosive's molecule. The combustion process of aluminium is slower than elements originating from the molecular decomposition. The reaction therefore has a two-stage path which extends the detonation process over time while decreasing its rapidity. The addition of aluminium in the case of ideal explosives, leads to a decrease in detonation velocity, which depends on both the size and the form of the aluminium particles [7]. The decrease in velocity results from the chemical inertness of aluminium molecules in the chemical reaction zone behind the shock wave front [8]. Moreover, the added aluminium significantly enhances the heat of explosion of ideal explosives [9].

Emulsion explosives exhibit similar behaviour. Their structure is characterised by a large contact surface between the oxidiser and the fuel. They can therefore be considered in a similar manner to chemically pure explosive compounds. Detonation velocities of emulsions decrease with increase in aluminium content. However, other detonation parameters, such as air blast pressure or energy of explosion, are improved [10-13]. The only exceptions are some low density, micro-balloon sensitised, emulsions, for which the detonation velocity increases with increase in aluminium content [14]. Unfortunately, such a high content of aluminium results in significant increases in production costs. Moreover, it causes some transport and loading problems. The addition of nitrocellulose powder extracted from expired ammunition was also analysed as an aluminium substitute in emulsion explosives [15]. It was assumed that this solution would be cost-effective and environmentally friendly as there is no toxic  $Al_2O_3$  in the post-blast gases. However, there is no practical application of this method in mining, to date.

Aluminium is highly reactive, though it is protected by a surface layer of  $Al_2O_3$ , which is rapidly formed when the metal is exposed to air. This provides excellent corrosion resistance. When adding aluminium to emulsion explosives, its surface is subjected to contact with a concentrated ammonium nitrate(V) solution. Due to the large contact surface, the addition of aluminium powder or flakes accelerates the oxidation process. In turn, aluminium granules intended for emulsion explosives are characterised by completely different behaviour. Thanks to a specific granulation process, the grain size undergoes an optimal selection for this purpose. Its surface is coated with agents, which prevent oxidation. The coated granules also ensure that the activity of the aluminium remains unchanged when the emulsion explosives are stored.

The article presents an assessment of the influence of aluminium content on the selected detonation parameters of bulk emulsion explosive commonly used in the Polish copper mining industry. The analysis covers the determination of relative explosive strength using ballistic mortar and Trauzl blocks, air blast pressure tests and detonation velocity measurements. Five types of emulsion explosives, differing in aluminium content including 0, 1, 3, 5 and 7%, were tested.



## 2. Material and methods

Studies were carried out at the Central Mining Institute's test site in Mikołów and at the NITROERG company test site in Krupski Młyn. The research was based on the Emulinit bulk emulsion explosive matrix. The matrix density was 1.42 g/cm<sup>3</sup> and consisted of:

- 55-60% ammonium nitrate(V),
- 15-20% calcium nitrate(V),
- 5-7% organic phase, and
- 12-15% water.

The sensitiser was based on sodium nitrate(III). The oxygen balance of the reference explosive (without aluminium) was 0.05%.

The aluminium granules chosen for the experimental study were from Hoesch Granules. The average aluminium content was 97% (approx) and the average particle size was 150 μm. Densities of emulsion explosives, determined 60 min after mixing of the matrix with aluminium and sensitiser at 20 °C, were as follows:

- 1.03 g/cm<sup>3</sup> (0% Al),
- 1.01 g/cm<sup>3</sup> (1% Al),
- 0.99 g/cm<sup>3</sup> (3% Al),
- 0.99 g/cm<sup>3</sup> (5% Al), and
- 0.98 g/cm<sup>3</sup> (7% Al),

indicating a slight decrease with increasing aluminium content.

A total of 45 samples were prepared for the tests, including 15 samples for the ballistic mortar test, 15 samples for the Trauzl lead block test, and 15 for the simultaneous measurement of the free field air blast wave and detonation velocity. Earlier studies of the time influence on the detonation velocity of tested explosive have shown that this parameter is highly variable [16]. Thus, in order to obtain reliable results, the samples were prepared separately and always tested after the same period of time following the beginning of the sensitisation reaction.

### 2.1. Ballistic mortar test

Determination of relative explosive strength is conducted using a standardised test facility. It consists of a ballistic mortar mounted on a ballistic pendulum at the end of which a firing chamber is located. A projectile in the form of a steel cylinder is inserted into the mortar. The sample is initiated using an 0.65 g PETN detonator. Following initiation, the projectile is fired from the mortar. As a result of forces acting in the opposite direction (recoil), the pendulum arm is propelled from the equilibrium position, and the maximum angle of swing is registered using a movable cursor on a graduated scale. The result is recorded as the angle of swing of the mortar. A view of the test facility and samples prepared for testing are presented in Figure 1.



(a)



(b)

**Figure 1.** Ballistic mortar (a) and explosive samples (b)

The angle of mortar swing is compared to that produced by the same mass of a reference charge of hexogen. The mass of the cylindrical sample (25 mm diameter) made into a cartridge in a tin foil wrapper, is 10 g. The test procedure is described in detail in Polish standard PN-C-86035:1999 [17]. Results are expressed as a percentage of that obtained for hexogen. A total of 15 emulsion explosive samples were prepared for the tests, differing in aluminium content (3 per each content) and 3 samples of the reference charge (hexogen).

## 2.2. Trauzl lead block test

This test is based on determining the expansion capacity produced by the detonation of 10 g of explosive in a cylindrical lead block with a diameter of 200 mm and height of 200 mm. In the centre of a solid block, a hole with a diameter of 25 mm and depth of 125 mm is located. The sample is initiated using an 0.65 g PETN detonator. The resulting expansion is compared to that produced with 10 g of picric acid with detonator (reference charge). Detonation of this charge at 15 °C results in a cavity of 310 cm<sup>3</sup>.

A total of 15 samples were prepared for the Trauzl test, including 3 samples for each aluminium content and 3 reference samples of pure picric acid recrystallised from water, dried and pressed to a density of 0.85 g/cm<sup>3</sup>. A view of the blocks prepared for the tests and the cross-section through a block before and after firing is presented in Figure 2.



(a)

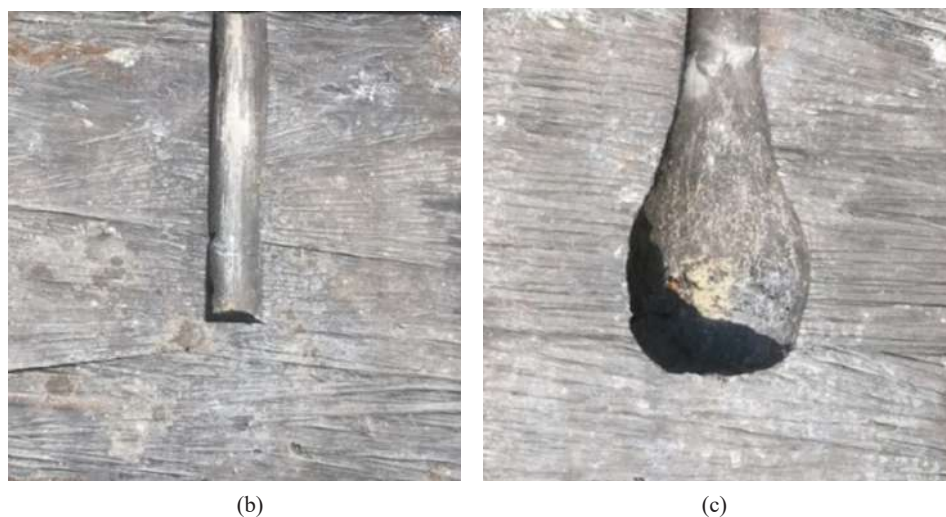

**Figure 2.** Blocks prepared for testing (a) and cross-section through a block before firing (b) and after firing (c)

The difference between the initial volume of a lead block is then compared to the expansion produced by the explosive. Finally, the relative explosive strength is expressed as a percentage in relation to the reference charge. The test procedure is described in detail in Polish standard PN-C-86037:2000 [18].

### 2.3. Detonation velocity measurement

Detonation velocity is the velocity at which a given shock wave front propagates through an explosive charge. The technique is based on measuring the travel time of the shock front between two sensors. The procedure is described in detail in standard PN-EN 13631-14:2005 [19]. However, in this paper, the continuous method was applied using a MicroTrap VOD/Data Recorder. This method generates results complementary to those obtained using the standard method [20].

Measurements using the MicroTrap recorder utilise the widely known wire resistance technique. A precise probe of known linear resistance is placed axially along the direction of detonation inside the explosive sample. As the shock wave front propagates, the explosive consumes the probe, and the resistance of the circuit decreases in proportion to the decrease in the probe's length. A recorder registers the probe resistance change as a function of time.

Samples were prepared by filling clear glass tubes, length of 500 mm, internal diameter of 46.4 mm and wall thickness of 1.8 mm, with the explosive. The explosive components were blended manually in a glass beaker using a glass rod. Components were previously weighed using a laboratory balance (0.01 g resolution). In the first step, the matrix was blended with the aluminium granules and then the sensitiser was added. The net mass of a single sample was 500 g. A total of 15 samples were prepared, differing in aluminium content the range of 0-7%. The probe was inserted axially inside the explosive charge. A view of selected samples is presented in Figure 3.

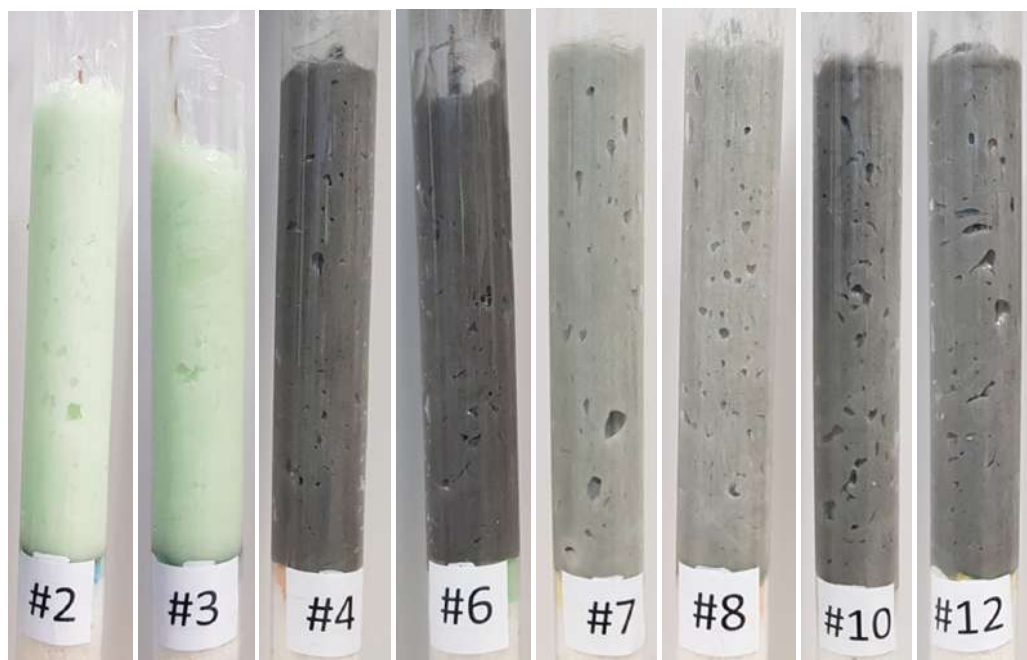

**Figure 3.** View of selected samples for detonation velocity tests

The samples were taped to a dedicated stand and fired in a vertical position in an explosive bunker. The bottom of the charge was located 85 cm from the floor. An instantaneous 0.65 g PETN electric detonator was placed at the top of the charge. A view of selected samples prior to firing is presented in Figure 4.

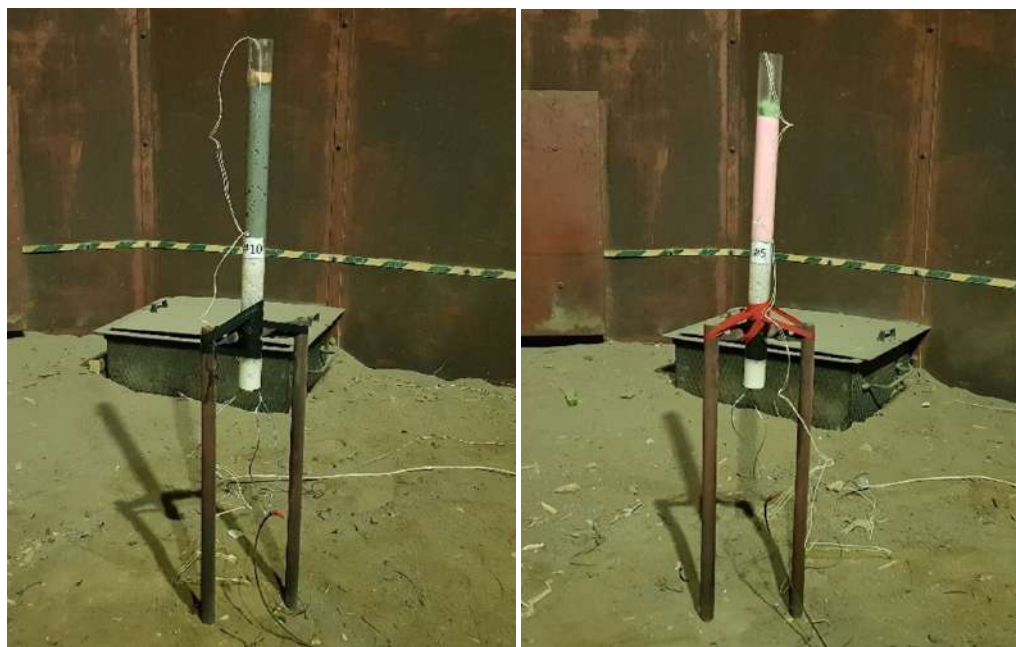
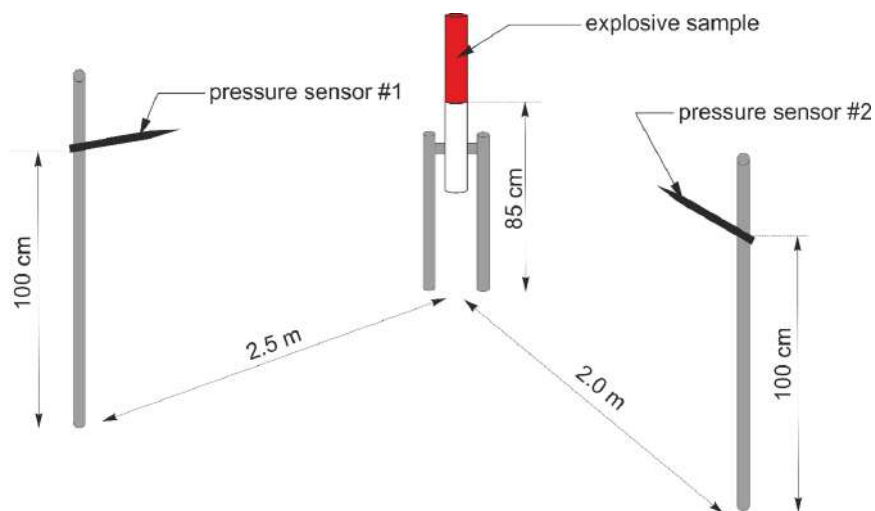

**Figure 4.** Selected samples prepared for firing

The same time of 60 min, between the blending of emulsion components and the sample being fired, was applied. As the components were blended manually, the interval between the firing of subsequent samples was approximately 15 min.

#### **2.4. Air blast testing**

Measurements of the free field air blast pressure were conducted using PCB 137B23B integral-electronics piezoelectric pressure sensors with a rise time of up to 6.5  $\mu$ s and a measuring range of 345 kPa. The tests were carried out in parallel with the detonation velocity measurements (for the same explosive samples). The sensors were placed 100 cm above the ground, at 2.0 and 2.5 m from the explosive sample. A diagram of the measuring system is presented in Figure 5.



**Figure 5.** Scheme of the air blast measurements

The data were recorded using a DEWESoft SIRIUS high-speed amplifier coupled with a computer. The sampling frequency was 1 MHz. Measurements were performed for each explosive sample. Peak overpressure, positive phase duration and positive phase impulse were determined from the data recorded on both sensors. Numerical integration, based on the trapezoidal rule (1  $\mu$ s time step size) was used to calculate the positive phase impulse.

### 3. Results

#### 3.1. Ballistic mortar

The results of explosive strength tests from the ballistic mortar, depending on aluminium content, are presented in Table 1. A relative value was determined for each aluminium content as an average based on 3 samples (same for samples of hexogen). Moreover, percentage values in relation to the samples without aluminium are presented. The relative explosive strength ( $X$ ) from the ballistic mortar was calculated using the following equation:

$$X = \frac{m_t}{m_r} \times 100 \quad [\%] \quad (1)$$

where  $m_t$  – arithmetic mean of  $(1 - \cos \alpha)$  for the tested explosive,  $m_r$  – arithmetic mean of  $(1 - \cos \beta)$  for the reference explosive.

The arithmetic means for the reference charge ( $m_r$ ) and tested explosives ( $m_t$ ) were calculated according to the following equations:

$$m_t = \frac{(1 - \cos \alpha_1) + (1 - \cos \alpha_2) + (1 - \cos \alpha_n)}{n} \quad (2)$$

$$m_r = \frac{(1 - \cos \beta_1) + (1 - \cos \beta_2) + (1 - \cos \beta_n)}{n} \quad (3)$$

where  $\alpha_1, \alpha_2, \alpha_n$  – angles of the pendulum swing for the tested explosive,  $\beta_1, \beta_2, \beta_n$  – angles of the pendulum swing for the reference explosive,  $n$  – number of tests.

**Table 1.** Results of ballistic mortar tests

	Aluminium content [%]				
	0	1	3	5	7
Relative explosive strength ( $X$ ) [%]	80.4	81.3	82.5	83.1	84.4
Dependence of relative explosive strength in relation to explosive without aluminium [%]	100.0	101.1	102.6	103.3	105.0

Results indicate a linear increase in relative explosive strength on a ballistic mortar with increase in aluminium content. The linear correlation coefficient ( $r$ ) of this relationship is 0.67 with a coefficient of determination ( $R^2$ ) of 0.981. The maximum aluminium content of 7% resulted in a 5% increase in relative explosive strength.

### 3.2. Trauzl lead block

Results of the Trauzl tests in relation to the aluminium content are presented in Table 2. The net expansion volume was determined for each sample, and the average value was then calculated for a given aluminium content. As above, the table also presents the percentage increase of lead block volume in relation to samples without aluminium.

**Table 2.** Results of Trauzl tests

Parameter	Sample No.	Aluminium content [%]				
		0	1	3	5	7
Net expansion in a lead block [cm <sup>3</sup> ]	1	304.0	323.5	325.5	358.5	359.0
	2	304.0	314.5	330.5	347.5	348.5
	3	299.5	320.5	322.0	340.0	352.5
	Average	302.5	319.5	326.0	348.5	353.5
Dependence of net expansion in a lead block in relation to explosive without aluminium [%]		100.0	105.6	107.8	115.2	116.9

The results showed that the volume in lead blocks produced by the detonation of explosive samples increases with increases in aluminium content. Within the considered ranges of added aluminium, the net expansion values ranged from 5.0 to 22.5 cm<sup>3</sup> per 2% added. The linear correlation coefficient of this relationship is 2.4 at a coefficient of determination of 0.944. The maximum volume was nearly 360 cm<sup>3</sup>, which corresponds to an increase of about 20%, compared to explosive samples without aluminium.

### 3.3. Detonation velocity

Detonation velocity was determined from the slope of the plotted curve based on any 2 points selected on the graph. The results are presented in Table 3. The recorded velocity values were rounded to 10 m/s. The table also shows the percentage change in detonation velocity compared to samples without aluminium.

**Table 3.** Results of detonation velocity tests

Parameter	Sample No.	Aluminium content [%]				
		0	1	3	5	7
Velocity of detonation [m/s]	1	4410	4300	4350	4360	4270
	2	4390	4320	4360	4370	4270
	3	4400	4280	4340	4320	4300
	average	4400	4300	4350	4350	4280
Dependence of detonation velocity in relation to explosive without aluminium [%]		100.0	97.7	98.9	98.9	97.3



The obtained results do not indicate any significant influence of the added aluminium on the detonation velocity value. A slight decrease in velocity with increase in aluminium content can be observed. However, when considering average values, they do not exceed 120 m/s for 7% of aluminium. Bearing in mind that the uncertainty in the MicroTrap system is  $\pm 2\%$  of the measured value, then at an average velocity of 4400 m/s (without aluminium), the system generates an error close to 90 m/s.

### 3.4. Air blast

Results of the air blast tests recorded using the SIRIUS amplifier are presented in graphical form. Based on the obtained waveforms of pressure as a function of time  $p = f(t)$ , the positive phase impulse ( $I_s$ ) was calculated using the trapezoidal rule of numerical integration according to the following formula [21, 22]:

$$I_s = \int_{t_1}^{t_2} p(t) dt \quad [\text{Pa}\cdot\text{s}] \quad (4)$$

where  $t_1$  – positive phase start and  $t_2$  – positive phase end.

Given the amount of data, peak overpressure values as well as the positive phase impulses and positive phase durations were presented as average values determined on the basis of 3 test samples of explosive. Results, in the form of average values and degree of uncertainty, are presented in Table 4.

**Table 4.** Results of air blast tests (average values)

Parameter	Aluminium content [%]				
	0	1	3	5	7
Peak overpressure $P_{s,2m}$ [kPa]	101.1 $\pm$ 1.3	105.3 $\pm$ 2.3	113.3 $\pm$ 3.4	110.1 $\pm$ 1.0	114.1 $\pm$ 2.2
Peak overpressure $P_{s,2.5m}$ [kPa]	58.3 $\pm$ 1.8	58.9 $\pm$ 1.9	63.5 $\pm$ 1.7	62.9 $\pm$ 1.4	63.5 $\pm$ 0.7
Positive phase duration $t_{s,2m}$ [ms]	1.126 $\pm$ 0.068	1.206 $\pm$ 0.014	1.231 $\pm$ 0.039	1.233 $\pm$ 0.034	1.244 $\pm$ 0.013
Positive phase duration $t_{s,2.5m}$ [ms]	1.443 $\pm$ 0.004	1.492 $\pm$ 0.009	1.506 $\pm$ 0.002	1.537 $\pm$ 0.024	1.532 $\pm$ 0.002
Positive phase impulse $I_{s,2m}$ [Pa·s]	45.4 $\pm$ 0.7	46.7 $\pm$ 0.2	48.2 $\pm$ 0.2	49.0 $\pm$ 0.2	50.3 $\pm$ 0.1
Positive phase impulse $I_{s,2.5m}$ [Pa·s]	36.0 $\pm$ 0.4	36.5 $\pm$ 0.1	37.5 $\pm$ 0.1	38.6 $\pm$ 0.1	39.8 $\pm$ 0.1

The results indicate that peak overpressure, positive phase duration and positive phase impulse, increase with increases in aluminium content. A comparison of the blast overpressure waveforms measured during detonation of an explosive sample with 7% aluminium and without aluminium is presented in Figure 6 (values averaged from 3 samples). The peak overpressure for the explosive without aluminium, at a distance of 2.0 m from the detonated sample, was approximately 101 kPa, and 58 kPa at a distance of 2.5 m. In turn, the peak overpressure measured for the sample with 7% of aluminium were 114 and 63 kPa, respectively. This indicates an increase of nearly 13% in air blast pressure at a distance of 2.0 m and nearly 9% at a distance of 2.5 m from the detonation. Furthermore, an increase in blast wave impulse duration was observed with increases in aluminium content. This was 0.118 ms at the sensor located 2.0 m from the sample and 0.089 ms at 2.5 m, which indicates an increase of 10.5 and 6.1% respectively compared to explosive samples without aluminium. In order to determine the influence of added aluminium on these parameters, percentage increases of air blast parameters were calculated with reference to an explosive without aluminium. Then, percentage increases recorded by the sensors located 2.0 m and 2.5 m from the detonated sample were averaged. Results are presented in Figure 7.

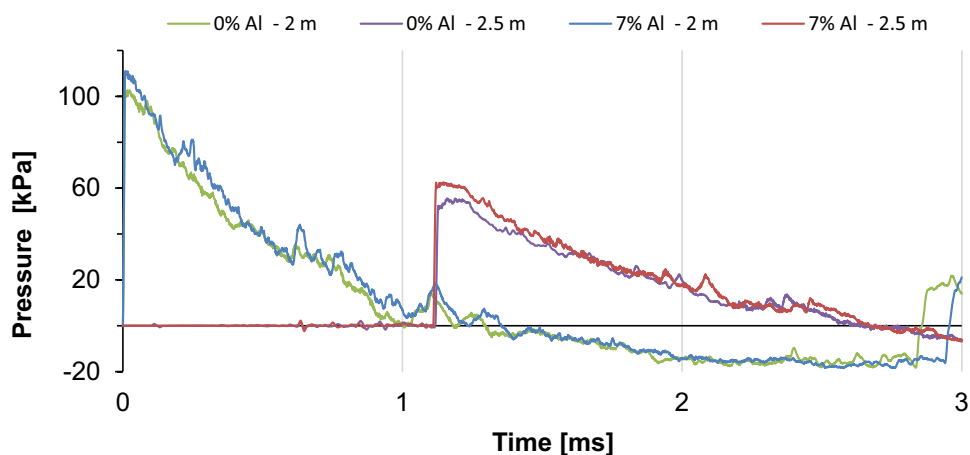

Figure 6. Blast pressure waveforms for 0 and 7% aluminium

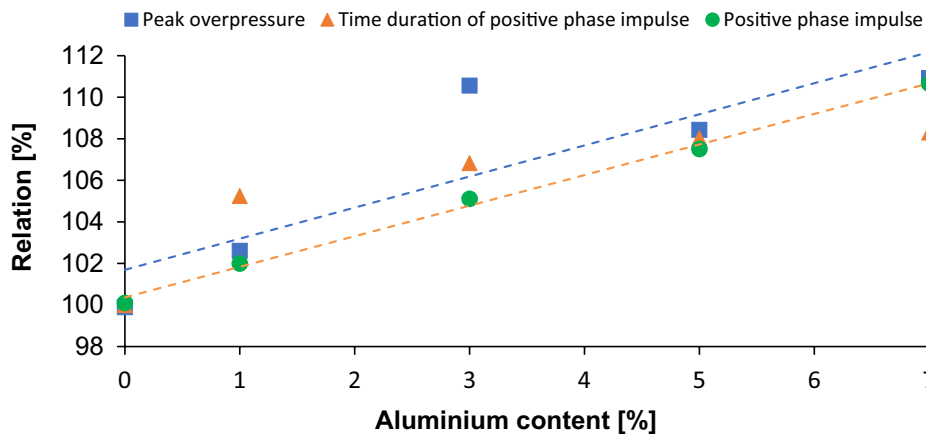

Figure 7. Percentage increases of the air blast parameters depending on aluminium content

The results show that the relationship between aluminium content and peak overpressure and positive phase impulse, is linear within the studied aluminium content range. The linear correlation coefficient of the peak overpressure is 1.49 at a coefficient of determination of 0.748. The linear character of this relationship is disrupted by the result obtained for the 3% content, for which the greatest dispersion of results around the average value was observed. Therefore, positive phase impulse seems to be the more suitable parameter for comparison of air blast characteristics. This allows any disturbances in the results to be filtered out. Thus, results are significantly improved and a smaller dispersion around the average value is observed. The linear coefficient of the positive phase impulse is 1.48, but at a much greater  $R^2$  coefficient of 0.996. In turn, the relationship of positive phase duration and aluminium content is not linear. For 1% of aluminium additive, the observed phase duration increase was 5.2%, whereas a 7% addition resulted in an increase of 8.3%, compared to an emulsion explosive without aluminium.

## 4. Discussion

Based on the presented analysis, one may conclude that no significant improvement was found by adding aluminium at an economically justified level and the detonation parameters of bulk emulsion explosives. Admittedly, the free field air blast parameters may be enhanced, but this is more important in military technology than mining. This is related to the influence of the blast pressure on a remote environment, which is not directly associated with rock fragmentation.

Determination of explosive strength using both methods, revealed divergent results. However, a linear increase in energetic parameters with an increase in aluminium in the range 0-7%, was observed. The least effect of aluminium addition was noticed in the ballistic mortar test, in which the linear correlation coefficient was 0.67. It can therefore be concluded that aluminium added to the tested emulsion explosive has a minor influence on brisance. In turn, the linear coefficient of the explosive strength in the Trauzl test was 2.40, which is over 3.5 times greater than that obtained with the ballistic mortar. This may indicate that addition of aluminium affects an improvement in the energetic properties of the analysed emulsion explosive, but that only a part of that energy is directly related to brisance, which is significant from a rock excavation point of view.

It should be noted that samples used for determining relative explosive strength with the ballistic mortar and Trauzl test are relatively small. When testing bulk emulsion explosives, some deviations and errors may occur. This is because the detonation process in such small samples is not fully developed and the detonation parameters do not achieve their optimal values. Furthermore, chemically sensitised emulsion explosives exhibit limited stability compared to those sensitised by a physical method. The placing of a detonator in a charge or handling such a small charge, can result in damage to the sensitised structure and migration of gas bubbles, which are the key factors influencing the initiation and detonation parameters. Preparation of small samples of sensitised explosive may also affect the accurate reproducibility of results.

The air blast test of a detonation of 500 g of bulk emulsion explosive, seems to be a more relevant approach. Results indicate a linear relationship between the positive phase impulse and aluminium content. In turn, the relationship between the aluminium content and positive phase duration demonstrates a significant increase for 1% of aluminium additive. Further increases in aluminium content do not correspond to the increase in positive phase duration. This is probably related to the fact that the addition of aluminium greater than 1% in the analysed case, does not react with the oxygen originating from the oxidiser phase of the matrix.

Another major issue is the addition of aluminium at the matrix production stage, which is associated with the use of additional dosing systems. The matrix of emulsion explosives is thermodynamically unstable, and any additions or inclusions have a negative influence on their stability. Moreover, they may accelerate the crystallisation process. The mixing-charging units used in Polish copper mining are equipped with static mixing devices in the form of a cross-stream static mixer. The pumping of a crystalline matrix, apart from the obvious influence on detonation parameters, results in the clogging of mixing devices. This in turn leads to increases of pressure above permissible values, which will stop the loading.

It should also be noted that an explosive matrix is delivered from the production plant to mines in tanker trucks or IBC tanks of 5.1 transport class (oxidising agents). An aluminium addition of 3% or greater may result in sensitisation of the matrix, thus changing its transport class to a higher, more restrictive, classification. It may also create an additional risks at the production stage. In most cases, infrastructure elements such as pipelines or storage tanks are not banded, and therefore they do not need to fulfil the strict requirements concerning transport and storage of explosives, since a pure emulsion matrix is not capable of detonation.

The last issue which needs to be raised is the presence of toxic aluminium oxides in the post-blast gases. This is particularly significant in underground mining. Explosives with added aluminium generate quantities of aluminium oxide nanoparticles during detonation, which has a negative impact on a mine's atmosphere, but may also increase the exposure risk of mine workers to potentially pathogenic agents [23].

## 5. Conclusions

The presented analysis concerning the influence of aluminium additives to selected detonation parameters of bulk emulsion explosives, has confirmed certain relationships between these factors. With an increase in aluminium content, the density of the analysed explosive initially decreases, and subsequently stabilises. With increases in aluminium content, the amount of oxygen in the oxidiser phase of the matrix is insufficient to burn the excess metal, which should result in a reduction of detonation velocity. However, within the considered range of aluminium addition, no significant influence on the detonation velocity was found, though a minor decrease with an increase in aluminium content was noted.

While the tests of relative explosive strength using ballistic mortar and Trauzl blocks may not reflect real detonation parameters due to the size of the sample, comparison of results obtained for the same explosive and under the same conditions, represents their character. The detonation velocity measurements and air blast tests were performed using much bigger samples. Diameters of charges were much greater than the critical diameter of the analysed explosive. This means that simulation of practical conditions was more realistic. Thus, correlation of the results from all test types is not an appropriate approach. However, certain conclusions can be drawn regarding the relationships between aluminium content and the strength and energy properties of explosive under given conditions.

From the results obtained, it can be concluded that addition of aluminium in the case of the analysed explosive affects the improvement of the detonation parameters (proportionally to the content), except the detonation velocity, which slightly decreases with an increase in aluminium content. This means that the general thermodynamic characteristic does not change significantly. The obtained results have proven that further research on alternative solutions aimed at enhancing the detonation parameters of chemically sensitised bulk emulsion explosives is justified.

## Acknowledgements

This paper has been prepared under the statutory research of the Central Mining Institute, work number 11121010. The authors would like to thank the management of NITROERG company for providing necessary facilities and assistance during the field investigations.

## References

- [1] Bluhm H.F. *Ammonium Nitrate Emulsion Blasting Agent and Method of Preparing Same*. Patent US 3447978, **1969**.
- [2] *Bulk Emulsion Explosives Emerging as Replacement of Packaged Counterparts in Underground Mining Application*. <https://www.futuremarketinsights.com/press-release/emulsion-explosive-market> [retrieved 10.06.2020].
- [3] Vadhe P.P., Pawar R.B., Sinha R.K., Asthana S.N., Subhananda Rao A. Cast Aluminized Explosives (Review). *Combust. Explos. Shock Waves* **2008**, 44(4): 461-477.
- [4] Maranda A., Paszula J., Zawadzka-Małota I., Kuczyńska B., Witkowski W., Nikolczuk K., Wilk Z. Aluminum Powder Influence on ANFO Detonation Parameters. *Cent. Eur. J. Energ. Mater.* **2011**, 8(4): 279-292.
- [5] Zygmunt B. Detonation Parameters of Mixtures Containing Ammonium Nitrate and Aluminum. *Cent. Eur. J. Energ. Mater.* **2009**, 6(1): 57-66.
- [6] Maranda A., Papiński A., Gałęzowski D. Investigation on Detonation and Thermochemical Parameters of Aluminized ANFO. *J. Energ. Mater.* **2003**, 21(1): 1-13.
- [7] Grishkin A.M., Dubnov L.V., Davidov V.Y., Levshina Y.A., Mikhailova T.N. Effect of Powdered Aluminum Additives on the Detonation Parameters of High Explosives. *Combust. Explos. Shock Waves* **1993**, 29(2): 239-241.
- [8] Bednarczyk E., Maranda A., Paszula J., Papiński A. Studies of Effect of Aluminium Powder on Selected

- Parameters of Emulsion Explosive Sensitized with Microballoons. *CHEMIK* **2016**, 70(1): 41-50.
- [9] Makhov M.N. Effect of Aluminum and Boron Additives on the Heat of Explosion and Acceleration Ability of High Explosives. *Russ J. Phys. Chem. B* **2015**, 9(1): 50-55.
- [10] Mishra A.K., Agrawal, H., Raut M. Effect of Aluminum Content on Detonation Velocity and Density of Emulsion Explosives. *J. Mol. Model.* **2019**, 25(3), 70: 1-5.
- [11] Qian H., Wu H.B., Xing H.D., Xia M.M. Effect of Aluminum Content and Particle Size on the Power of Emulsion Explosives. *Chin. J. Explos. Propell.* **2017**, 40(1): 40-44.
- [12] Mendes R., Ribeiro J.B., Plaksin I., Campos J. Non Ideal Detonation of Emulsion Explosives Mixed with Metal Particles. *AIP Conf. Proc.* **2012**, 1426(1): 267-270.
- [13] Paszula J., Trzeciński W., Sprzątczak K. Detonation Performance of Aluminum – Ammonium Nitrate Explosives. *Cent. Eur. J. Energ. Mater.* **2008**, 5(1): 3-11.
- [14] Satonkina N.P., Bordzilovsky S.A., Danilko D.A., Ershov A.P., Karakhanov S.M., Plastinin A.V., Rafeichik S.I., Yunoshev A.S. Influence of Aluminum on the Characteristics of Detonating Emulsion Explosives. *J. Phys. Conf. Series* **2018**, 1128(1): 012063.
- [15] Biegańska J. Using Nitrocellulose Powder in Emulsion Explosives. *Combust. Explos. Shock Waves* **2011**, 47(3): 366-368.
- [16] Mertuszka P., Kramarczyk B. The Impact of Time on the Detonation Capacity of Bulk Emulsion Explosives Based on Emulinit 8L. *Propellants Explos. Pyrotech.* **2018**, 43(8): 799-804.
- [17] PN-C-86035:1999: *Explosives – Determination of Relative Explosive Strength by Ballistic Mortar.* (in Polish) **1999**.
- [18] PN-C-86037:2000: *Explosives – Determination of Explosive Strength in a Lead Block.* (in Polish) **2000**.
- [19] PN-EN 13631-14:2005: *Explosives for Civil Uses – High Explosives – Part 14: Determination of Velocity of Detonation.* (in Polish) **2005**.
- [20] Mertuszka P., Pytlik M. Analysis and Comparison of the Continuous Detonation Velocity Measurement Method with the Standard Method. *Mater. Wysokoenerg. (High Energy Mater.)* **2019**, 11(2): 63-72.
- [21] Steckiewicz A., Trzeciński W.A. Investigation of Blast Wave Characteristics Produced by Improved Explosive Charges. (in Polish) *Biuletyn WAT* **2009**, 58(2): 217-230.
- [22] Ullah A., Ahmad F., Jang H., Kim S., Hong J. Review of Analytical and Empirical Estimations for Incident Blast Pressure. *KSCE J. Civ. Eng.* **2017**, 21: 2211-2225.
- [23] Krewski D., Yokel R.A., Nieboer E., Borchelt D., Cohen J., Harry J., Kacew S., Lindsay J., Mahfouz A.M., Rondeau V. Human Health Risk Assessment for Aluminum, Aluminum Oxide, and Aluminum Hydroxide. *J. Toxicol. Environ. Health Sci. B* **2007**, 10(1): 1-269.

Received: June 16, 2020

Revised: November 18, 2020

Published first time online: November 25, 2020



*Cent. Eur. J. Energ. Mater.* 2021, 18(4): 429-447; DOI 10.22211/cejem/144498

Article is available in PDF-format, in colour, at:

<https://ipo.lukasiewicz.gov.pl/wydawnictwa/cejem-woluminy/vol-18-nr-4/>



Article is available under the Creative Commons Attribution-Noncommercial-NoDerivs 3.0 license CC BY-NC-ND 3.0.

*Research paper*

## Study of the Influence of Sensitizer Content on the Density of a Bulk Emulsion Explosive Used in Underground Operations

Bartłomiej Kramarczyk<sup>1)</sup>, Piotr Mertuszka<sup>2,\*</sup>)

<sup>1)</sup> NITROERG S.A., 1 Nobla square, 43-150 Bieruń, Poland

<sup>2)</sup> KGHM Cuprum Ltd. Research & Development Centre,  
2-8 Sikorskiego Street, 53-659 Wrocław, Poland

\*E-mail: [piotr.mertuszka@kghmcuprum.com](mailto:piotr.mertuszka@kghmcuprum.com)

### ORCID information:

Kramarczyk B.: 0000-0003-0826-0002; Mertuszka P.: 0000-0002-2539-104X

**Abstract:** Emulsion matrix sensitization is typically performed by chemical reduction of the density using different sensitization agents. Mixing of the components takes place directly inside the loading hose, which is equipped with static mixing devices. Precise dosing of the components, due to the multi-ingredient nature of the mixture, has a significant impact on the detonation and operational parameters of the end product. However, the operation and maintenance of the mixing-charging units in underground mines is very difficult due to the local conditions. As a consequence, different values for the detonation parameters may be expected when charging the same explosive into blastholes using two different charging units. The present article presents the results of laboratory testing of the influence of the sensitizing agent content on the density of a bulk emulsion explosive. Analysis confirmed that increasing the concentration of the sensitizing agent by 30% and 50% led to density reductions by 4% and 7%, respectively. In turn, reducing the sensitizer content by the same percentages resulted in an increase in the final density by 7% and 8%, respectively.

**Keywords:** blasting, emulsion explosives, density measurements, chemical sensitization

## 1 Introduction

### 1.1 Emulsion explosives

Already in 1964, intensive research on slurry explosives had led to the patenting of the first composition of ammonium nitrate (AN)-containing emulsion sensitizers by the American chemists Richard Egly and Albert Neckar [1]. The developed water-in-oil emulsion explosive consisted primarily of an aqueous AN solution and fuels, plus additions like AN prills that made the emulsion capable of detonation. Later in 1969, Harold Frederick Bluhm [2], from Atlas Chemical Industries, patented the water-in-oil emulsion explosive, in what is commonly accepted as the date for the discovery of emulsion explosives. Currently, this type of explosive is primarily used worldwide for hard rock extraction in both underground and surface mining, but also in civil engineering, tunnelling and demolition. According to the forecast by Future Market Insights [3], the global sales of emulsion explosives is projected to reach 13 million tonnes by the end of 2029.

In most cases, attempts at mechanizing the process of solid rock extraction have not reached a successful level thus far [4]. In fact, certain solutions exist, but their implementation on an industrial scale is not economically feasible [5]. It can therefore be predicted that the use of explosives, including emulsion explosives, will remain at a comparable level in the coming years. A similar trend can be observed in Polish underground copper mines, where the current annual consumption of AN-based emulsion explosives varies between 16 and 18 thousand tonnes, of which over 70% are bulk emulsion explosives. The blastholes in these mines are loaded using mixing-charging units installed on blasting utility vehicles. Explosives are produced directly at the point of loading using these mixing-charging units. These units mix the emulsion with additives (gassing additives) which produce small bubbles in the final products (and the density changes due to the increase in volume). These small bubbles, which are known as “hot spots”, are able to change the detonation properties of the emulsion. Further details on the physics of this hot spot process can be found elsewhere [6]. The mixing of the emulsion and the gassing additives takes place inside the loading hose, which is equipped with static mixing devices in the form of cross-stream static mixers. Unfortunately, consistent delivery of the explosives by the mixing-charging units and their operators is very difficult due to the conditions present underground, of which the most important is a high rock mass temperature (up to 55 °C locally), high air temperature (above 30 °C) and extremely high humidity (above 95%). As a consequence, completely different results for the velocity of detonation (VOD) and fragmentation may be observed

when loading the same explosive into blastholes using two different units. This problem is also associated with the operation of piston pumps, mainly when the blasting vehicle is travelling between the faces and panels (stuck and air locked pistons). In such cases, they do not dose the sensitizer properly. This results in a discontinuity of the lubricating film, which increases the pressure in the loading hose. Finally, smaller amounts of sensitizer result in a higher final density.

The density of an emulsion explosive has a direct impact on its sensitivity and explosion capability, as well as on the efficiency of blasting operations [7-9]. Due to the scale of the blasting operations in Polish copper mines, explosives are detonated at almost 700 faces daily. This raises doubts as to whether all of the blastholes are fired at densities that are optimal for a given explosive. Operational matters are also important, since the explosives may be fired from 30 min up to 48 h after loading. Such a long period of time between the loading and firing of the explosives has a very negative influence on their detonation performance [10, 11].

The idea for the investigations described herein arose from a study of the influence of time on the density of a bulk emulsion explosive performed in 2018 in an underground Polish operation. These tests confirmed a significant relationship between these parameters [12]. In the framework of the research, 40 samples of bulk emulsion were collected from 4 randomly selected mobile mixing-charging units (10 samples from each unit). The tests were based on density measurements at selected time intervals after loading. Analysis demonstrated that the initial density values varied for samples collected from each unit. Moreover, the density of samples collected from each unit decreased at a different rate. It was also found that the final density was reached at different times. In one case, no change in the density over time was observed for any of the samples from one of the mobile mixing-charging units, which indicates incorrect mixing of the emulsion with the gassing additives (also known as the “sensitisation process”). Therefore, the present authors have attempted to assess the influence of the sensitizer content on the density of a bulk emulsion explosive under laboratory conditions.

## 1.2 Sensitization of emulsion explosives

Emulsion explosives consist primarily of oxidisers, water, fuels, emulsifiers as well as sensitizers and modifiers of their physicochemical properties [13]. The emulsion matrix itself, consisting of an oxidiser and fuel phase, is not capable of detonation, and therefore needs to be sensitized. This can be achieved by adding plastic microballoons or glass microspheres (physical sensitization) or the appropriate chemical compounds (chemical sensitization). Chemical



sensitization can be performed in many ways by means of chemical reactions that generate gaseous products evenly distributed in the emulsion [14]. The most popular method is based on the reaction of sodium nitrite with AN (present in the emulsion). After mixing, the sodium nitrite and the matrix, the following reaction occurs:



The ammonium nitrite formed is very unstable and decomposes in an acidic environment, giving off nitrogen, as follows:



Since the saturated AN solution is trapped in the organic continuous phase and its contact with the sodium nitrite is hindered, the diffusion process is very slow, and thus a high component temperature is required to ensure proper kinetics of the system. To accelerate the reaction at lower temperatures, the addition of a nucleophilic activator, in the form of thiourea, should be applied:

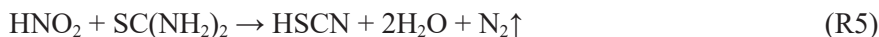

This also leads to further reactions by the diffusion of the reagents, as well as their intermediate forms, through a thin oil film [6]. Furthermore, the nitrous acid molecule undergoes decomposition with the release of gas:



Based on the above formulas, one may conclude that reaction in the emulsion sensitization is a multi-stage process, and that each stage involving emission of gaseous products affects the final density. The exact course of these reactions is not fully known, and their order and rate are influenced by numerous factors, such as the type and content of the emulsifier (the thickness of the oil film determining the speed of the diffusion process), the degree of dispersion (characteristics of the production plant), the acidification method, the influence of salt additives in the oxidizing phase, the type and content of the buffering agent, *etc.* Overall, it can be stated that the process of sensitization using sodium nitrite for various emulsion matrix formulations is complex and

strictly unique, depending on the ingredients used and the technical parameters of the manufacturing plant.

In some cases, the abovementioned optimisation measures on the rate of the sensitization process are insufficient. In open-pit mining, where the rock mass temperature varies widely with the season, an additional acidifier, such as an acetic acid solution during winter, should be utilised in order to accelerate the sensitization reaction. Then, the reaction takes place outside the emulsion structure, avoiding the diffusion processes, according to the following formulas:



The excess of nitrogen oxide is released outside the reaction zone, where it forms nitrogen dioxide by reaction with oxygen from the air, visible as brown smoke in the area of the blasthole, as per reaction R9:



In turn, additional acidification is avoided in underground mining in order to decrease the toxic products (nitrogen oxides ( $\text{NO}_x$ ) released from the gassing process). A single sensitizing agent is used, which is mixed into the emulsion matrix using the mixing-charging unit. This reaction occurs in the entire volume of the mass, and results in uniform gassing of the mixture and activates the matrix [15]. The most important operational parameter in the case of chemical sensitization is the rate of gas bubble production, and thus the time required to achieve the required final density of the emulsion.

In practice, the kinetics of this reaction depend primarily on the pH of the reagents, temperature and concentration of the active components. Industrially, the pH is already regulated at the preparation of the oxidiser solutions stage. The safety constraints for handling large amounts of acidified AN allow for a slight and strictly controlled reduction of the pH, as there have been cases of self-decomposition of hot acidified AN solutions in the past [16].

The temperature of the reaction in mines depends primarily on the rock mass temperature, as the reaction is initiated after mixing of the components and loading into the blasthole. The change in rock mass temperature affects the speed of sensitization. Moreover, in many cases the firing of the explosives is delayed due to unpredictable situations related to the complex nature of mining operations.

During that time, the density of the emulsion explosive forming in the blasthole is changing, and leads to changes in VOD.

The concentrations of the reagents are strictly defined according to the formula specified by the components manufacturer. The proportions of the components may change during working due to the difficult operating conditions of the dosing systems. The proportions, and thus the concentrations of the reagents, affect the speed of the sensitization reaction, but their influence on the final density is much greater. This is also a problem from a technical point of view, as the flow of the sensitizer in the loading hose serves as a lubricant coating of the inner surface of the hose in order to improve the flow of the matrix. Feeding of insufficient amounts of the sensitizing agent may result in clogging of the hose with the emulsion and blocking of the entire system. In such a case calibration of the unit is required in order to verify whether the desired volumes of matrix and sensitizer are dispensed at specific pump rotations.

Keeping the mixing-charging units in good working order is very difficult due to the conditions present in the mine described earlier. This is particularly true for underground mining. It may therefore lead to situations where the components of the emulsion explosive are pumped into the blastholes in the wrong proportions. This has a direct impact on the sensitization and the VOD (and potentially the detonation pressure) of the end product [17].

## 2 Materials

The first part of the study was to verify the density values of bulk emulsion explosives measured underground by shotfirers. According to the implemented procedure, each loading of blastholes must be preceded by a sensitization test. The density is determined by dividing the weight of the sample by the volume of the cup. During this test, a plastic cup is filled with the mixture of the matrix and sensitizer. While gassing, the emulsion is levelled with the top edge of the cup and weighed. The result is the value of the density 30 min after loading, which is noted in the form of a face charging report. The result is acceptable if the density value lies within the defined range, according to the applicable instruction.

The present analysis covered results of the density measurements obtained over a period of 4-5 months and included 4 randomly selected underground mixing-charging units. The number of measurements for each unit was different, as it was dependent on the frequency of the tests. Thus, the analysis included:

- 219 tests for unit #1,
- 184 for unit #2,

- 212 for unit #3, and
- 232 tests for unit #4.

The results are shown in Figure 1, where the horizontal axis represents the successive tests. The red dashed horizontal lines are the minimum and maximum densities for the considered explosive, which should be within the range of 0.95 to 1.25 g/cm<sup>3</sup>.

Analysis confirmed a significant dispersion of the emulsion densities, both when comparing the individual units, and in terms of the values obtained for each unit during the period considered. In total, nearly 4% of the results were outside the required range. Particularly unfavourable results were observed for unit #1, for which as many as 22 values were outside the correct density range, and means a deviation of 10%. The average densities were as follows:

- 1.11 g/cm<sup>3</sup> for unit #1,
- 1.10 g/cm<sup>3</sup> for unit #2,
- 1.11 g/cm<sup>3</sup> for unit #3, and
- 1.14 g/cm<sup>3</sup> for unit #4,

which gives an average density of 1.12 g/cm<sup>3</sup> (for all tests and units). The standard deviation of the results ranged from 0.06 g/cm<sup>3</sup> for unit #3 to 0.09 g/cm<sup>3</sup> for units #1 and #4 (0.08 g/cm<sup>3</sup> for the overall data).

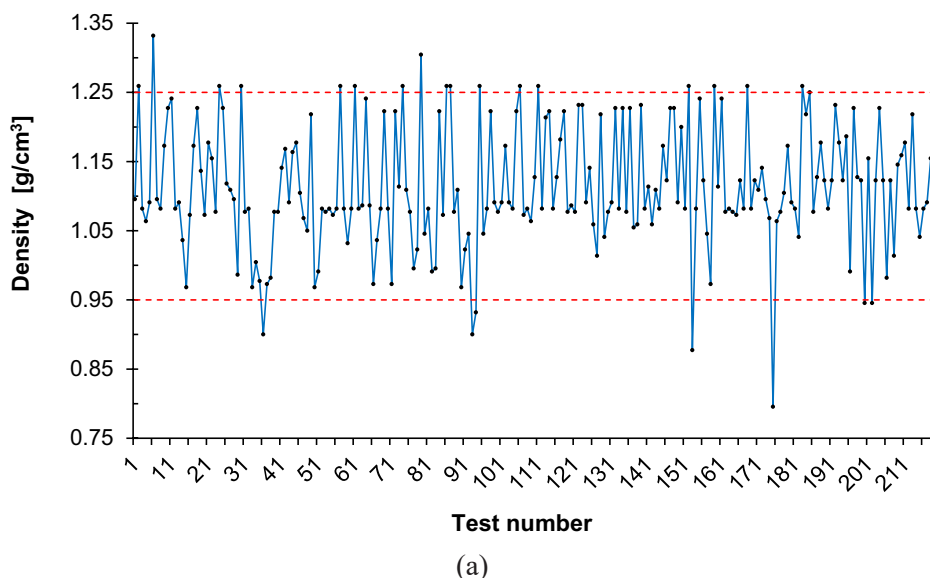

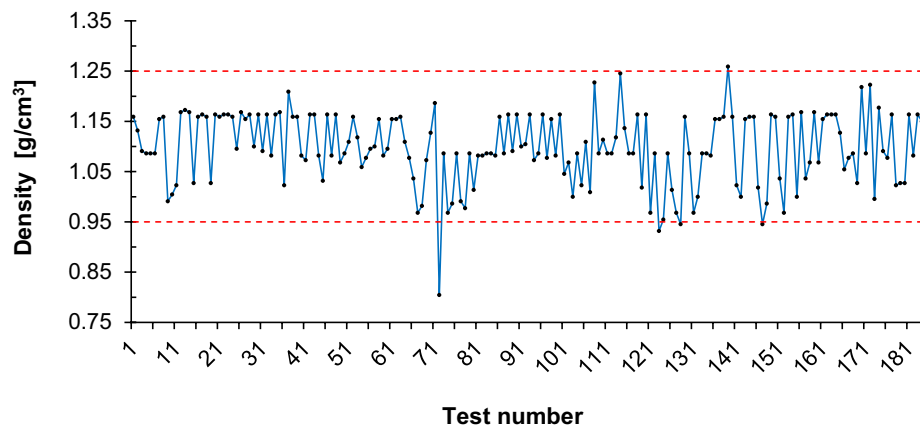

(b)

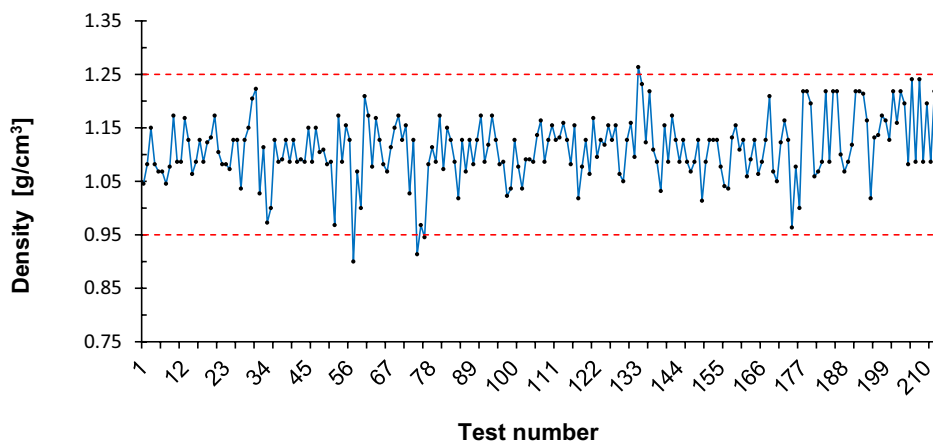

(c)

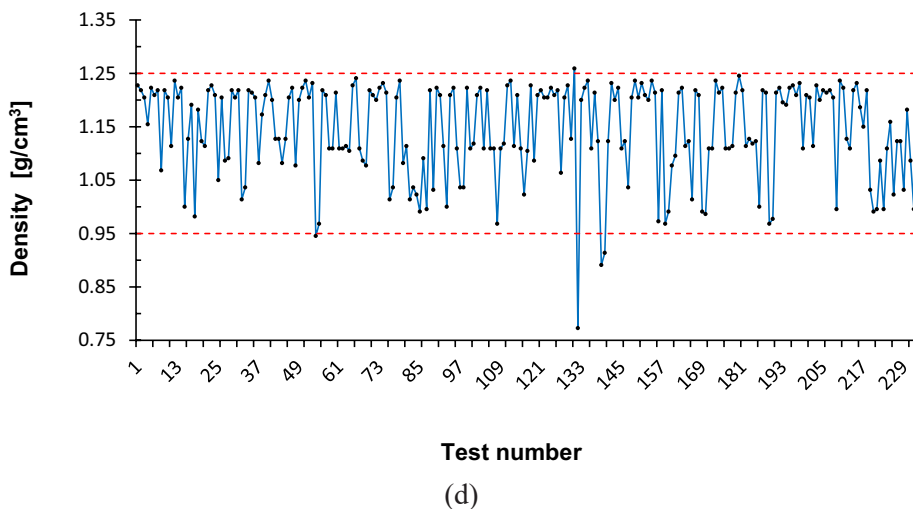

**Figure 1.** Results of density measurements for the selected units #1 (a), #2 (b), #3 (c) and #4 (d)

This indicates that sensitization under underground conditions is not fully controlled. Consequently, different densities may be observed when loading the same explosive into a blasthole using different units. This means that completely different VODs may be expected. Moreover, this may have a significant impact on the rock fragmentation. This can result from incorrect blending of the components in the loading hose. Inappropriate component dosing may also be an issue, since it can lead to the acceleration or deceleration of the sensitization. In such cases, calibration of the mixing unit is required.

It should also be highlighted that an incorrect density of an emulsion explosive may affect propagation of the detonation wave and cause other issues, such as partial burn or misfire, as such an explosive does not contain the necessary amount of reacting hot spots. Low-density emulsions are characterised by a high initiation sensitivity. Such explosives are less energetic than high-density ones, which in turn are characterised by lower sensitivity but higher detonation velocity and concentration of energy [18].

Based on the above, the authors have attempted to pursue the study under laboratory conditions, the purpose of which was to determine the influence of sensitizer content on the density of a bulk emulsion explosive. Laboratory testing has allowed other factors present at the firing site to be eliminated. It was assumed that this type of research would verify whether sensitization of an emulsion matrix, consisting in changes of density over time, is a fully controllable process. The tests were based on the Emulinit bulk emulsion

explosive manufactured by NITROERG S.A. (Poland), the same one as used for the density tests from different units (presented earlier). Selected parameters of the tested explosive, according to the EU-type examination certificate, are shown in Table 1. All of these were obtained for densities in the range of 0.95-1.05 g/cm<sup>3</sup>. Unfortunately, the authors did not have access to the formulation of the sensitizer solution due to the manufacturer's proprietary information.

**Table 1.** Selected parameters of the tested explosive

Parameter	Value
Critical diameter [mm]	34
VOD [m/s]	3,800 <sup>a)</sup>
Oxygen balance [%]	0.05
Trauzl lead block test [cm <sup>3</sup> ]	225
Friction sensitivity [N]	360
Impact sensitivity [J]	>30
Energy [kJ/kg]	3,546 <sup>b)</sup>

<sup>a)</sup> for a diameter of 40 mm (unconfined VOD measurement), <sup>b)</sup> for a density of 1 g/cm<sup>3</sup>

The explosive samples were prepared using matrixes differing in storage times following their collection from the production line, including matrix M-1 collected 21 days before testing, matrix M-2 collected 7 days prior to testing and matrix M-3 collected 1 day before testing. This allowed the influence of matrix storage time on sensitization to be assessed. The matrix temperature was stable at 24.5 °C. The samples were prepared in the plastic cups. The analysis covered a standard dose of sensitizer for the tested explosive, as well as doses reduced by 30% and 50%, and doses increased by 30% and 50%. Six samples were prepared for each of the three matrixes and each sensitizer dose, giving a total of 90 samples. The first step was to measure the required doses of matrix and sensitizer. For this purpose, an electronic laboratory balance and plastic cups were used (Figure 2). The components were blended manually in 500 mL plastic cups using a glass rod. The blending time of a single sample was 30 s. After that, the mixture was poured into a 115 mL plastic cup. The sensitization time was controlled independently for each sample. As the volume of the matrix mixed with the sensitizer increased as a result of the chemical reaction, the excess of emulsion was scrapped off from the top of the cup and the samples were weighed at 5-min intervals for 60 min using an electronic laboratory balance. The samples were additionally weighed after 24 h. A view of the samples during the sensitization is presented in Figure 3.

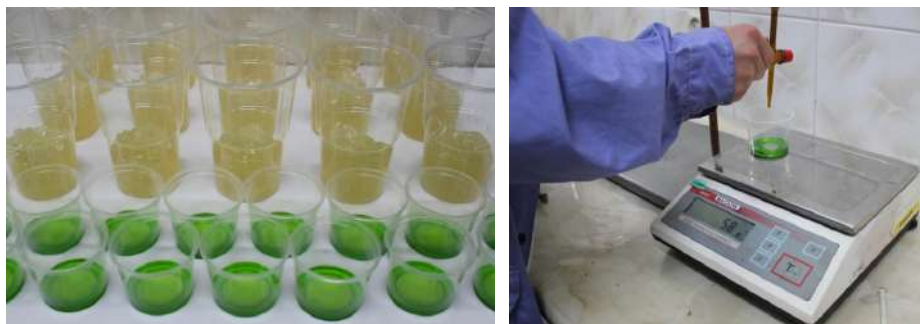

**Figure 2.** Preparation of the emulsion components



**Figure 3.** Selected samples during sensitization

The relevant matrix/sensitizer ratio for the Emulinit explosive was 95.5% to 4.5% (by mass). The modified sensitizer contents for the purposes of the tests were:

- 2.25% (–50% in relation to the standard content),
- 3.15% (–30%),
- 5.85% (+30%), and
- 6.75% (+50%).

### 3 Method

The explosive density ( $\rho$ ) was determined based on the ratio of the net sample mass to the cup volume, according to the following formula:

$$\rho = \frac{m}{V} \left[ \frac{\text{g}}{\text{cm}^3} \right] \quad (1)$$

where:  $m$  – sample mass (without cup) [g],  $V$  – cup volume [ $\text{cm}^3$ ].



## 4 Test Results

Due to the large number of measurements and the repeatability of the results for individual samples within a given series, the analysis involved the average values for 6 samples (Table 2). The analysis showed that the density values for the samples prepared from matrixes collected from the production line at different time intervals are very similar. This indicates that the storage time of the matrix does not affect the sensitization. However, this only applies to the considered period of time, *i.e.* three weeks. An analysis of longer storage times of matrix is not justified, as the average consumption of bulk emulsion explosives in Polish copper mines is about 40 tonnes per day. Given such a high demand for explosives, the time between the production of the matrix and underground firing does not usually exceed 7 days.

The analysis confirmed the clear influence of the percentage content of the sensitizer on the density of the bulk emulsion explosive and the changes in density over time. Reducing the sensitizer content by 30% resulted in an average increase in the density of the end product by 6-8% ( $0.07 \text{ g/cm}^3$ ) after 60 min. Further reduction of the sensitizer content to 2.25% led to an increase in density to  $1.10 \text{ g/cm}^3$ . In turn, increasing the percentage sensitizer content from 4.5% to 5.85% resulted in a decrease in density by  $0.04 \text{ g/cm}^3$ . The clearest downward trend can be observed for the highest sensitizer content (+50%), which resulted in a decrease in density to  $0.93\text{-}0.94 \text{ g/cm}^3$ . In this case, sensitization is faster, which caused that emulsion to become oversensitized.

The results of these measurements are also presented in graphical form in Figures 4-6. In these cases, the density values were also averaged for samples from the individual measurement series. The results indicated that sensitization in each case progressed in a similar way. This confirmed that the manual blending of components had no negative impact on the course of the chemical reaction. The trend of the decrease in density over time was very similar for each matrix tested. The same applied to the trend in density decrease between different sensitizer contents.

**Table 2.** Average results of the density measurements

Matrix	Time [min]	Density [g/cm <sup>3</sup> ] for sensitizer content [%]				
		2.25	3.15	4.50	5.85	6.75
		(-50%)	(-30%)	Nominal value	(+30%)	(+50%)
M-1	5	1.31	1.33	1.31	1.29	1.28
	10	1.26	1.27	1.24	1.22	1.21
	15	1.23	1.23	1.19	1.17	1.16
	20	1.22	1.20	1.17	1.14	1.11
	25	1.20	1.19	1.14	1.11	1.09
	30	1.18	1.18	1.12	1.09	1.06
	35	1.17	1.17	1.10	1.07	1.04
	60	1.11	1.09	1.02	0.98	0.94
	1440	1.02	0.92	0.79	0.71	0.67
M-2	5	1.31	1.34	1.31	1.29	1.28
	10	1.27	1.28	1.25	1.22	1.22
	15	1.23	1.22	1.19	1.17	1.16
	20	1.22	1.21	1.16	1.13	1.12
	25	1.19	1.18	1.15	1.11	1.09
	30	1.18	1.17	1.12	1.10	1.07
	35	1.17	1.16	1.11	1.07	1.03
	60	1.10	1.09	1.01	0.97	0.93
	1440	1.01	0.91	0.80	0.70	0.65
M-3	5	1.31	1.33	1.30	1.29	1.29
	10	1.27	1.27	1.24	1.22	1.22
	15	1.23	1.23	1.19	1.17	1.16
	20	1.22	1.21	1.16	1.13	1.12
	25	1.20	1.19	1.14	1.12	1.10
	30	1.18	1.17	1.12	1.09	1.07
	35	1.17	1.16	1.10	1.06	1.04
	60	1.10	1.08	1.02	0.98	0.94
	1440	1.02	0.93	0.78	0.71	0.65

The explosive densities after 60 min ranged from 0.93 g/cm<sup>3</sup> for the increased content of sensitizer to as much as 1.11 g/cm<sup>3</sup> for the lowest content. Particularly important are the values of density obtained after 60 min from the beginning of sensitization and with increased content of the sensitizer. This indicated that the density was within the lower range of the value defined as correct and may suggest that the explosive will be characterised by a lower VOD.

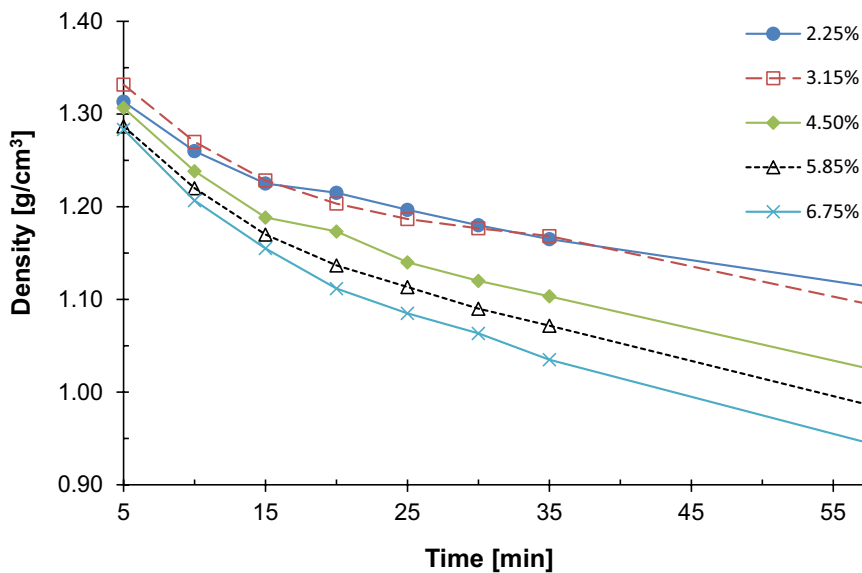

Figure 4. Changes in density over time during sensitization (matrix M-1)

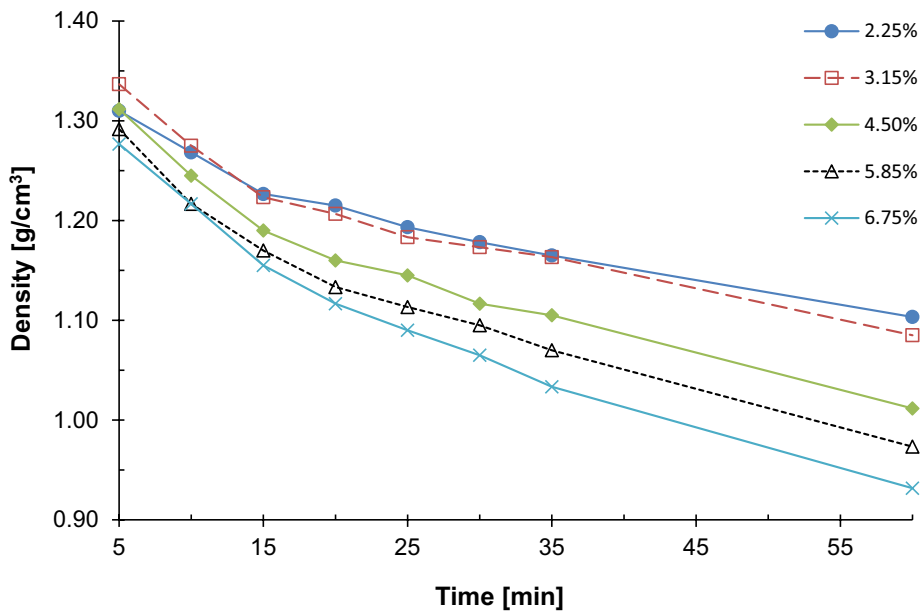
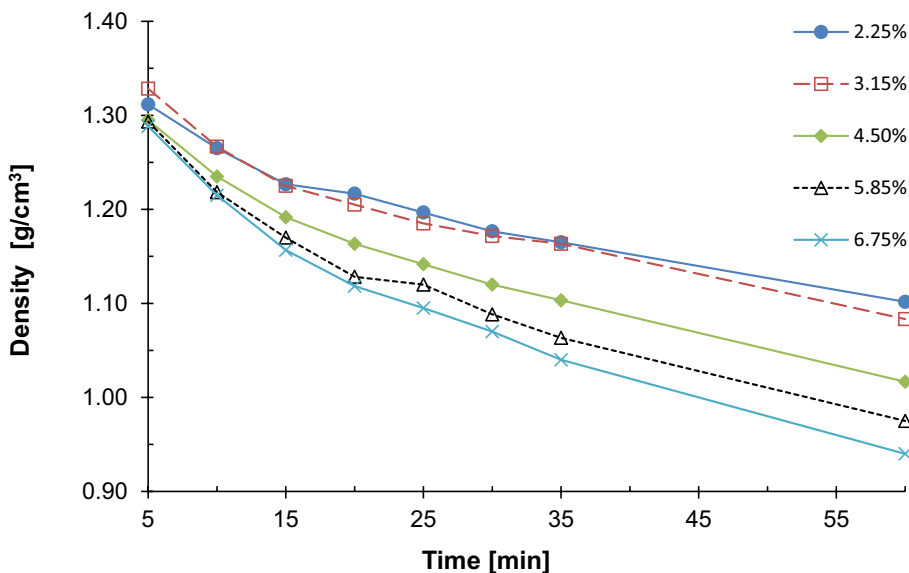

Figure 5. Changes in density over time during sensitization (matrix M-2)



**Figure 6.** Changes in density over time during sensitization (matrix M-3)

The analysis confirmed that incorrect dosing of components has a significant impact on the density of the tested bulk emulsion explosive. In fact, a decrease in density during the first 60 min will result in a VOD increase. However, as shown on the last line of Table 2, a density below  $0.8 \text{ g/cm}^3$  could translate into lower VODs. Therefore, the periodic calibration of the mixing-charging units is such an important factor, and has a direct impact on the detonation properties of emulsion explosives, and thus on the effectiveness of the blasting operations.

## 5 Discussion of Results

This study has confirmed that the sensitizer content has a significant effect on the density of a bulk emulsion explosive and that there are changes in density over time from the moment of sensitization. According to the EU-type examination certificate issued by a notified body, the density of the Emulinit explosive should be between  $0.80$  and  $1.25 \text{ g/cm}^3$ . However, according to the universal instructions for sensitization process control for this type of explosive at a nominal sensitizer content of  $4.5\%$ , the density after 30 min at  $25 \text{ }^\circ\text{C}$  should range from  $0.95$  to  $1.25 \text{ g/cm}^3$ . It should therefore be assumed that values below  $0.95 \text{ g/cm}^3$  are defined as incorrect. Furthermore, the certificate also states

that this explosive may be stored in blastholes for up to 48 h. For technological and organizational reasons, explosives in blastholes in Polish copper mines can be fired from 30 min to 48 h after loading. It can, therefore, be assumed, that not all of the charges are fired at optimal densities.

Consequently, the densities of all of the samples were measured again after 24 h and then after 48 h. The samples were stored in a room with a stable temperature of 25 °C. The results are presented only for the measurements after 24 h, as no further changes in the volumes of the explosive samples were observed after this time.

The density values measured after 24 h indicated that the considered explosive is very sensitive to the passage of time. Reducing the sensitizer dose by 50%, *i.e.* to 2.25% by mass, resulted in an average density increase of 0.29 g/cm<sup>3</sup> (in relation to the initial value) to 1.02 g/cm<sup>3</sup>. Such a density should not affect the detonation parameters of the explosive. On the other hand, increasing the sensitizer content led to a decrease in density to a value below the acceptable level. The actual values were 0.71 g/cm<sup>3</sup> for 5.85% of sensitizer and 0.65 g/cm<sup>3</sup> for 6.75%. In principle, such a low-density of a bulk emulsion explosive is characterised by a very high sensitivity to initiation, but they are less energetic than high-density ones. This is usually accompanied by a lower VOD and low energetic content by volume. Furthermore, it should be noted that an incorrect density was also observed for a standard sensitizer dose after 24 h, which was 0.79 g/cm<sup>3</sup>. Certainly, such a low density can only be achieved under laboratory conditions, when the blending of the components is very precise. Mixing of components using charging units in mines is not as precise as manual mixing, hence the nominal content of the sensitizer will not effect such a significant decrease in density. This is because during the mechanical charging, the flow of components in the loading hose is laminar and mixing takes place using a cross-stream static mixer. Due to large differences in the viscosity of both components, the fast flow and relatively short mixing time limited by the length of the static mixer (optimized pressures in the loading hose), complete mixing is not possible, compared with manual mixing under laboratory conditions. Obviously, the density obtained does not have to influence the detonation capacity of the explosive, but it may significantly influence its detonation parameters.

## 6 Conclusions

- ◆ The results of this experimental research on the impact of sensitizer content on the density of a bulk emulsion explosive, carried out under laboratory conditions, have confirmed that there is a significant relationship between these two parameters. The sensitizer content affects both the final density value (complete conversion of components) and changes in density over time from the moment of sensitization. Reducing the sensitizer content below the recommended level results in a higher density, which is related to a lower amount of lubricant coating on the inner surface of the loading hose. From a mining perspective, this makes proper mixing of the components and the pumping of explosives into the blastholes more difficult, and has a negative impact on the operational parameters of emulsion explosives.
- ◆ Analysis confirmed that increasing the concentration of the sensitizing agent by 30% and 50% led to density reductions of 4% and 7%, respectively. In turn, reducing the sensitizer content by the same percentages resulted in increases in the final density by 7% and 8%, respectively. Bulk emulsion explosives with densities outside the recommended range may exhibit different detonation parameters compared to the declared ones, which in turn may affect the effectiveness of blasting operations.
- ◆ Retaining the optimal emulsion densities in mines until firing in blastholes is a key factor directly influencing the efficiency of blasting.
- ◆ From the perspective of mining operations, the following significant factors should therefore be taken into consideration:
  - verifying the gassing reaction according to instructions before charging of blastholes,
  - controlling the sensitizer content in the explosive and maintaining it at the recommended level,
  - firing of faces in the shortest possible time after charging (considering the recommended 30 min) in order to ensure the maximum efficiency of blasting,
  - training and verification of knowledge and skill of the mixing-charging units' operators, which seems to be one of the most important factors.

## References

- [1] Egly, R.S.; Neckar, A.E. *Ammonium Nitrate-containing Emulsion Sensitizers for Blasting Agents*. Patent US 3161551, **1964**.
- [2] Bluhm, H.F. *Ammonium Nitrate Emulsion Blasting Agent and Method of Preparing Same*. Patent US 3447978, **1969**.
- [3] *Bulk Emulsion Explosives Emerging as Replacement of Packaged Counterparts in Underground Mining Applications*. Future Market Insights, Press release, **2020**.
- [4] Sifferlinger, N.A.; Hartlieb, P.; Moser, P. The Importance of Research on Alternative and Hybrid Rock Extraction Methods. *Berg Huettenmaenn Monatsh.* **2017**, *162*(2): 58-66.
- [5] Pickering, R.G.B.; Young, C. Controlled Foam Injection: A New and Innovative non-Explosive Rockbreaking Technology. *J. South. Afr. Inst. Min. Metall.* **2017**, *117*(3): 237-243.
- [6] Da Silva, G.; Dlugogorski, B.; Kennedy, E. Water-in-Oil Emulsion Foaming by Thiourea Nitrosation: Reaction and Mass Transfer. *AIChE J.* **2006**, *52*(4): 1558-1565.
- [7] Agrawal, H.; Mishra, A.K. A Study on Influence of Density and Viscosity of Emulsion Explosive on Its Detonation Velocity. *Model. Meas. Control. C* **2017**, *78*(3): 316-336.
- [8] Lee, J.; Persson, P.A. Detonation Behavior of Emulsion Explosives. *Propellants Explos. Pyrotech.* **1990**, *15*(5): 208-216.
- [9] Sitkiewicz-Wołodko, R.; Maranda, A. Analysis of Selected Parameters of Saletrols and Emulsion Explosives. *CHEMIK* **2016**, *70*(1): 11-18.
- [10] Pradhan, M. Sleep Time: Its Consequences on Performance of Bulk Emulsion Explosive. *J. Sci. Ind. Res.* **2010**, *69*(2): 125-128.
- [11] Mertuszka, P.; Kramarczyk, B. The Impact of Time on the Detonation Capacity of Bulk Emulsion Explosives Based on Emulinit 8L. *Propellants Explos. Pyrotech.* **2018**, *43*(8): 799-804.
- [12] Mertuszka, P.; Fuławka, K.; Pytlik, M.; Wincenciak, J.; Wawryszewicz, A. The Influence of Time on the Density and Detonation Velocity of Bulk Emulsion Explosives – A Case Study from Polish Copper Mines. *Cent. Eur. J. Energ. Mater.* **2019**, *16*(2): 245-258.
- [13] Mahadevan, E.G. Emulsion Explosives. In: *Ammonium Nitrate Explosives for Civil Applications: Slurries, Emulsions and Ammonium Nitrate Fuel Oils*. Wiley, Weinheim, **2013**; ISBN 978-3-527-33028-7.
- [14] Kabamba, K.J. *Development of Two-Component Gassing System to Sensitize Explosive Emulsions*. MEng. dissertation, Cape Peninsula University of Technology, **2019**.
- [15] Field, J.E. Hot Spot Ignition Mechanism for Explosives. *Acc. Chem. Res.* **1992**, *25*: 489-496.
- [16] Negovanović, M.; Kričak, L.; Milanović, S.; Đokić, N.; Simić, N. Ammonium Nitrate Explosion Hazards. *Undergr. Min. Eng.* **2015**, *27*: 49-63.

- [17] Tao, T.J.; Zhang, J.H.; Chi, E.A.; Zhao, M.S.; Kang, Q. Study of Influence of Sensitization Process on Quality of Mixed Emulsion Explosive. *Adv. Mat. Res.* **2014**, *1033-1034*: 1305-1308.
- [18] Mishra, A.K.; Rout, M.; Singh, D.R.; Pada Jana, S. Influence of Gassing Agent and Density on Detonation Velocity of Bulk Emulsion Explosives. *Geotech. Geol. Eng.* **2018**, *36*(1): 89-94.

Received: September 22, 2020

Revised: December 3, 2021

First published online: December 21, 2021



## Article

# Novel Sensitizing Agent Formulation for Bulk Emulsion Explosives with Improved Energetic Parameters

Bartłomiej Kramarczyk <sup>1,2</sup> , Mateusz Pytlik <sup>3</sup> , Piotr Mertuszka <sup>4</sup> , Katarzyna Jaszcz <sup>2</sup>  and Tomasz Jarosz <sup>2,\*</sup> <sup>1</sup> NITROERG S.A., 1 Alfred Nobel Square, 43-150 Bierun, Poland; b.kramarczyk@nitroerg.pl<sup>2</sup> Department of Physical Chemistry and Technology of Polymers, Silesian University of Technology, 44-100 Gliwice, Poland; katarzyna.jaszcz@polsl.pl<sup>3</sup> Conformity Assessment Body, Central Mining Institute, 1 Gwarków Square, 40-166 Katowice, Poland; mpytlik@gig.eu<sup>4</sup> KGHM CUPRUM Ltd. Research & Development Centre, 2-8 Sikorskiego Street, 53-659 Wrocław, Poland; piotr.mertuszka@kgmcuprum.com

\* Correspondence: tomasz.jarosz@polsl.pl

**Abstract:** Bulk emulsion explosives, although they are very convenient and safe to use, also have disadvantages, with the main one being the relatively low power in relation to cartridge emulsion explosives or classic nitroesters (e.g., dynamites). Therefore, materials of this type currently have only limited use. In addition, these materials are characterized by the variability of blasting parameters over time from loading into the blasthole, which is closely dependent on the utilised mining method of the mine, which makes it difficult to precisely control the fragmentation. The industry is trying to respond to the demand for bulk emulsion explosives with increased energy and improved parameter stability, but so far it has not been possible to do so in a safe and effective way. Methods of improving blasting parameters mainly rely on additives to oxidant solutions during production, which creates additional risks at the production stage, as it involves handling hot and concentrated ammonium nitrate solutions, for which there are known cases of uncontrolled decomposition of such solutions, even leading to an explosion. This paper presents a method of improving the thermodynamic parameters and the stability of the sensitization reaction without the need for changes in the oxidant solution.

**Keywords:** emulsion explosive; velocity of detonation; ability to perform mechanical work



**Citation:** Kramarczyk, B.; Pytlik, M.; Mertuszka, P.; Jaszcz, K.; Jarosz, T. Novel Sensitizing Agent Formulation for Bulk Emulsion Explosives with Improved Energetic Parameters. *Materials* **2022**, *15*, 900. <https://doi.org/10.3390/ma15030900>

Academic Editor: Aleksander B. Vorozhtsov

Received: 1 December 2021

Accepted: 18 January 2022

Published: 25 January 2022

**Publisher's Note:** MDPI stays neutral with regard to jurisdictional claims in published maps and institutional affiliations.



**Copyright:** © 2022 by the authors. Licensee MDPI, Basel, Switzerland. This article is an open access article distributed under the terms and conditions of the Creative Commons Attribution (CC BY) license (<https://creativecommons.org/licenses/by/4.0/>).

## 1. Introduction

Emulsion explosives (EEs) are a fairly recently developed and constantly evolving class of energetic materials [1–3] that feature high safety parameters and excellent performance benchmarks, comparable in some cases to the performance of dynamites. EEs are obtained by sensitizing an EE matrix—a water-in-oil emulsion of ammonium nitrate—either physically (e.g., with the use of glass microspheres) or chemically (e.g., through tractions, in which gas is released within the entire volume of the matrix), with the two types of processes being used to produce cartridge and bulk EEs, respectively. Regardless of their form of use, the development of EEs with continuously improving properties is a highly-active and multidisciplinary field that attracts significant scientific interest, focused on various aspects of those materials, be it their rheology [4,5], their energetic properties [6,7] or their safety features [8]. Most of the recent developments in the field focus on introducing a variety of additives into the EE formulations [9,10].

In the case of bulk EEs, which are produced in-situ using special mixing and loading units, the possibility of supplementing the EE with powdered raw materials is very limited. This results from the fact that static mixers, which are widely used in mixing-pumping units, are not suited to mixing solid components, with any larger solid aggregates posing the risk of blocking the mixer, making further loading impossible. Consequently, the sensitizing agent must be employed in the form of a liquid, so as to provide lubrication of the loading hose.

In the case of cartridged EEs, the above limitations can be avoided and it is therefore much easier to modify the detonation parameters of such blasting agents. Many studies report the use of demilitarised high explosives, such as TNT [11], RDX [12], Composition B, HMX and NC/NG-based smokeless powders [13], as supplements to EEs, allowing disposal of those explosives and increasing the energetic parameters of such supplemented EEs formulations [14], but those high explosives need not originate from reclamation efforts, as pristine high explosives are reported to be used as EE sensitizing supplements [15]. It should be noted, however, that emulsion explosives should, by design, consist of safe and non-explosive components, supplementing them with high explosives does not comply with this design and compromises the increased production, handling and usage safety of emulsion explosives.

Among other potential additives to EEs, the use of concentrated hydrogen peroxide was also investigated, as a possible method of minimising the amount of harmful gases (i.e. carbon monoxide, nitrogen oxides) emitted upon detonation [16,17]. The drawback to this approach is that concentrated hydrogen peroxide is highly reactive, with even traces of contaminants or elevated temperatures inducing its decomposition. Consequently, alternative methods of sensitizing EEs, without compromising their safety features, are of significant research interest. Titanium and magnesium hydrides are examples of some among the newly proposed sensitizing agents [18,19]. Although such supplements are theoretically promising, they are not without drawbacks. To exemplify, in the case of metal hydrides, which are highly reactive, the risk of hydrogen evolution and formation of an explosive atmosphere needs to be considered (particularly so in conditions of poor ventilation, such as is common in underground mining). Additionally, the price and sophisticated storage requirements result in the use of metal hydrides as EE supplements being impractical.

Additions of perchlorates to the solutions of the oxidising phase of emulsions are also known [20], but due to the production process, where we are dealing with concentrated solutions of ammonium nitrate at a temperature of about 90 °C, adding any reactive ingredients may increase the risk of uncontrolled decomposition or even explosion. It has been proven that aluminium additives do not give satisfactory results [21]. Additionally, the presence of aluminium can cause problems during production because it requires the use of additional dosing systems. Blasting fumes containing  $\text{Al}_2\text{O}_3$  have a negative effect on the health of employees. All of the above methods of improving parameters may pose a safety risk. The main assumption of emulsion explosives is to achieve a high degree of safety during production, transport, use and decontamination of waste. Therefore, including high-energy additives directly in the emulsion matrix should be avoided, as it should remain a safe system of primary oxidising agents and safe fuels. The sensitizer should not be a hazardous substance, as well. High concentrations of sodium nitrite increase the risk of poisoning. In the case of contamination, nitrogen oxides may be released. Such a formulation of components allows them to remain classified into transport category 5.1 (oxidising agent). The assumption of the work was not to change the composition of the emulsion matrix. The change in the formulation of the sensitizer was aimed at improving the sensitization parameters (speed and stability) with an additional improvement of detonation parameters and obtaining a more favorable and ecological composition of blasting fumes.

The current reference composition of the sensitizing component is comprised by approx. 4.5 wt.% of active ingredients and as much as 95.5 wt.% of water. Introducing water into the mixed bulk EEs reduces its sensitivity to detonating stimuli, increases the critical diameter and negatively affects the detonation parameters, lowering the velocity of detonation and the explosion temperature. The presented research topic aims to develop safe bulk EEs that exhibit increased energy. The most promising of the considered solutions seems to be the replacement of a part of the water of the sensitizing component with oxidizing, reducing and active sensitizing components. The mixture contained in the new component during detonation would react in an explosive way, increasing the energy

effect of the reaction, while active sensitization is to support the gas sensitization process, the optimal form of which is nitrogen gasification.

Sensitizing the EE charges chemically results in the formation of gas bubbles in the bulk of the charge. This process is a type of foaming and its progression is associated with a gradual decrease in the density of the charge over time. The rate of the reaction, through which gas is formed is dependent on temperature. This dependence is undesirable, particularly when conducting blasting operations in rocks, whose temperature is either particularly high or particularly low, as it can significantly accelerate or decelerate the progression of the EE sensitizing process. Unfortunately, within safe pH values of the oxidising solution in the EE matrix, the sensitization rate is strictly dependent on the temperature of the components. Typically, the EE charges become sensitive to initiation once their density drops below  $1.25 \text{ g/cm}^3$ , although the degree of mixing of the components is also a key factor that needs to be taken into account. The performance of the charges is strongly dependent on their density [22,23]. The instability of density over time is a significant issue that limits the application of chemically sensitized bulk emulsion explosives. The key aims of this work were to:

- Improve the detonation parameters of new bulk explosives,
- Improve the quality of the spoil fraction,
- Increase the sensitivity of bulk explosives to shock and reduce their critical diameter,
- Improve the stability of bulk EE performance over time,
- Streamline and improve the reliability of existing loading systems in the context of their application in underground and open pit mines,
- Increase the oxygen balance value and limit the amount of nitrogen oxides and carbon monoxide produced during blasting,
- Maintain the current transport classification (Class 5.1, as per the guidelines for the transport of dangerous goods [24]) and the level of safety during production and transport.

## 2. Materials and Methods

### 2.1. Materials

#### 2.1.1. Components of the Emulsion Explosive Formulation

All tests were performed on the same batch of emulsion matrix (supplied by Nitroerg S.A.) for underground bulk emulsion formula, containing ammonium nitrate, calcium nitrate, water, oil, emulsifier and auxiliary components.

The main sensitizing component was an aqueous solution of sodium nitrite (>95%, Standard Sp. z o.o., Lublin, Poland). This was used to sensitize the standard product Emulinit 8L bulk emulsion explosive matrix. As a modification, sensitizing components were made in which, in addition to sodium nitrite as a sensitizing agent, auxiliary components such as ammonium nitrate (fertilizer grade, Zakłady Azotowe Puławy, Puławy, Poland), sodium perchlorate (>95%, Arkema, Colombes, France), pH modifier and dye were added. The inclusion of these components is what differentiates the BK-1 and BK-2 formulations from the previous Emulinit 8L bulk emulsion explosive formulation. The relevant details of the composition of the EE matrix and tested EE formulations are given in Table 1.

**Table 1.** Summary of the components of the tested explosive formulations.

EE Matrix			
Component	Concentration (wt.%)		
Ammonium nitrate	55–60		
Calcium nitrate	15–20		
Organic phase	5–7		
Water	12–15		
Tested sensitizing agent formulations <sup>1</sup>			
Component	Concentration (wt.%)		
	Emulinit 8L	BK-1	BK-2
Ammonium nitrate	-	30	47
Water	95.45	61.6	41
Sodium perchlorate	-	4	8
Sodium nitrite	4.5	3	3.3
pH modifier and dye	0.05	1.5	0.7

<sup>1</sup> The Emulinit 8L formulation has been described in earlier works [21,25–28].

### 2.1.2. Auxiliary and Reference Materials

1,3,5-Trinitro-1,3,5-triazinane (RDX) and flaked 2,4,6-trinitrotoluene provided by Nitrochem (Bydgoszcz, Poland) were used as reference explosive materials for investigating the ability of the samples to perform mechanical work and for investigating brisance via the Hess method.

The probes used for velocity of detonation (VoD) measurements were produced by MREL, model PROBEROD (electrical resistivity 331.7  $\Omega$ /m) were used. The lead rods (purity > 99.97%,  $\Phi$  = 40 mm) were used as received.

## 2.2. Experimental Procedures

### 2.2.1. Preparation of Emulsion Explosives and Experimental Samples

The explosive components were blended mechanically in a plastic vessel with a capacity of 2 dm<sup>3</sup> using an electrically powered mechanical stirrer equipped with a propeller-shaped stirring rod. The components were stabilized to a constant temperature of 25 degrees Celsius and the mixing took place each time at the same temperature. The material prepared in this way was quickly elaborated into charges and conditioned at a constant temperature for a period of 3 h at constant temperature. The large batches of each explosive type were used as the reservoir, from which samples for the individual tests were taken.

Samples for microscopic observations were placed on the base microscope glass slide in the form of thin layers.

Samples for the determination of the composition of post-detonation gases were prepared in glass pipes, with one end sealed with clay, due to the fact that glass and clay are inert materials that are known not to interfere with gas analysis.

The samples for the ballistic mortar test were produced by mixing the components by hand, due to the sample amounts being insufficient for using the mechanical stirrer. After mixing, 10 g samples were accurately weighed.

The fundamental properties and performance parameters of the tested EE formulations were predicted using EXPLO5 software provided by OZM Research s.r.o. and the most relevant parameters were verified experimentally, as described in the following subsections.

### 2.2.2. Investigation of the Density of Charges over Time

Open vessels with a set volume of 115 cm<sup>3</sup> were weighed and loaded with the EE samples without leaving any voids or bubbles. Any excess of the EE was scraped off from the top of the cup to maintain the set volume of the samples, followed by weighing of the vessel. This was repeated every 5 min for the first hour, as well as after 180 and

1440 min have elapsed, in order to establish a time-resolved density profile for each of the investigated EE formulations.

### 2.2.3. Microscopic Observations

A ZEISS Primotech polarised light microscope was used to observe the structure of samples. Both the pure EE matrix and complete EE formulations (Emulinit 8L, BK-1, BK-2) were observed, at a magnification of 10×.

### 2.2.4. Determination of the Ability to Perform Mechanical Work

The ability of the EE charges to perform mechanical work was evaluated using a ballistic mortar. The detonation of a set mass (10 g charges were used, as is most common) of an explosive propels the mortar, moving it out of equilibrium. The maximum angle, to which the mortar was moved out of equilibrium, is recorded and used as the measure of the ability of the sample to perform mechanical work. Due to the nature of this method, it is most suitable for comparative trials. Therefore, a reference explosive is employed, against which the samples are tested. In this work, 1,3,5-trinitro-1,3,5-triazinane (RDX) was used as the reference material, with flaked 2,4,6-trinitrotoluene acting as a secondary reference material. Consequently, the relative ability of a sample to perform mechanical work ( $X$ ) is given as a relative value (% of the ability of RDX to perform mechanical work), calculated using Equation (1).

$$X = \frac{m}{m_R} \cdot 100\% \quad (1)$$

where:

- $m$ —arithmetic average of  $(1 - \cos(\alpha))$  values for the tested explosive
- $m_R$ —arithmetic average of  $(1 - \cos(\alpha))$  values for the reference explosive

### 2.2.5. Determination of Air Blast Parameters

The parameters of the shock wave generated by the investigated EE charges were determined using two pressure sensors—type 137B23B piezoelectric pressure sensors (PCB PIEZOTRONICS) were used. In this test, the EE charge was hung vertically, 100 cm above the ground. The pressure sensors were placed at different angles, at a distance of 200 and 250 cm, respectively, from the axis of the tested EE samples (Figure 1). Sensor data was recorded using a DEWESoft SIRIUS high-speed amplifier coupled with a computer capable of sampling data at a frequency of 1 MHz.

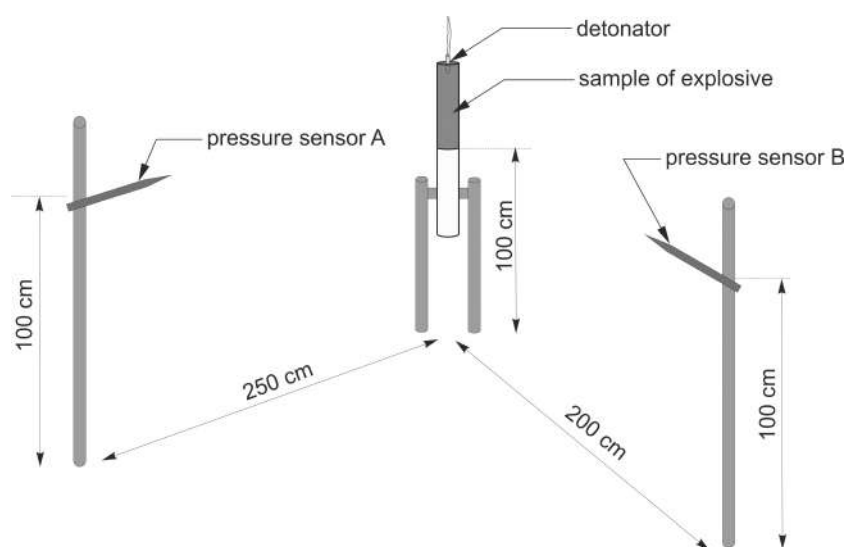

**Figure 1.** Outline of the experimental set-up for determining shock wave parameters.

### 2.2.6. Determination of Detonation Velocity

Detonation velocity values were investigated by the electrical method, based on the change of electrical resistance of a conducting probe, using a MicroTrap (MREL, Kingston, ON, Canada) velocity of detonation recorder. The VOD ProbeRod with a unit resistance of 331.7 ohm/m was inserted axially into the EE sample from the opposite end of the detonator. Then the ProbeRod was connected to the coaxial cable to transmit the signal to a MicroTrap™ VOD/Data Recorder, as shown in Figure 2. The detonation velocity experiments were conducted after the sensitised charges were left to stand in ambient conditions for 3 h. Samples were prepared by filling clear glass tubes, length of 500 mm, internal diameter of 46.4 mm and wall thickness of 1.8 mm, with the explosive. The VoD value was determined from the slope of the distance vs. time curve recorded for the VoD probe, as exemplified by the sample curve presented in Figure A1.

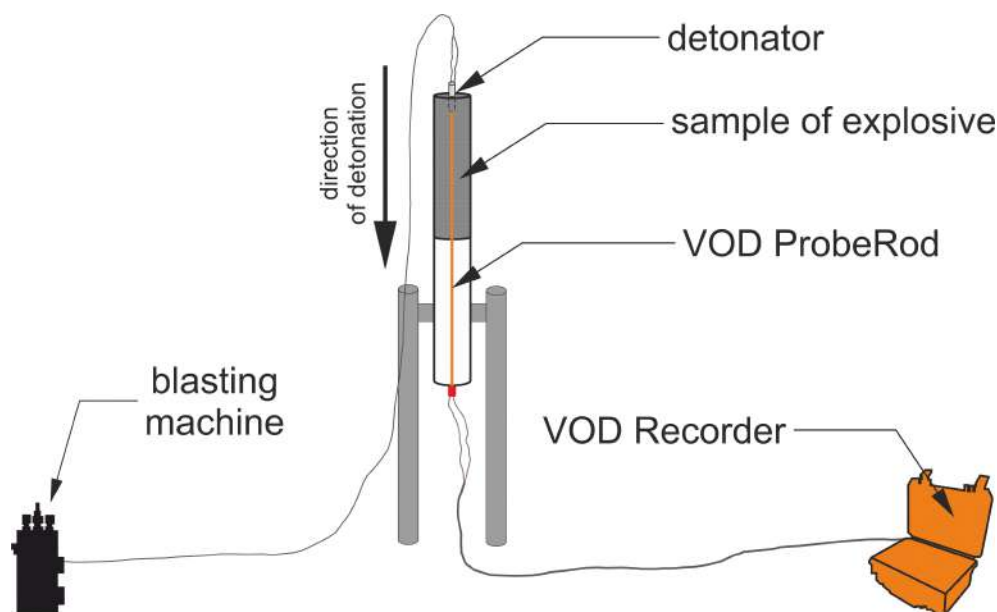

**Figure 2.** Schematic depiction of the experimental set-up for measuring velocity of detonation.

### 2.2.7. Determination of the Composition of Post-Detonation Gases

The experiments were conducted in accordance with the EN 13631-16:2006 standard [29]. The EE charges of a set mass of 530 g were placed in glass tubes and stemmed with clay. The load was placed in the mortar inside the blasting chamber with a volume of 15 m<sup>3</sup> (Figure 3). The tested explosive is initiated from the bottom by a secondary charge of 650 mg pentaerythritol tetranitrate. After the detonation of the tested charge, a mixing system is run for three minutes, in order to homogenize the gas mixture composition in the entire volume of the test chamber. The amounts of toxic oxides in the post-detonation gases were determined using continuous measurement chemiluminescent (TOPAZE 32M using a dual chamber for NO, NO<sub>x</sub> and NO<sub>2</sub> determination) and infrared (MIR 25 for CO and CO<sub>2</sub> determination) absorption analyzers. The concentration of each gas is recorded 20 min after the detonation of the test charge. Based on these values, the volume of each gas generated per unit mass (1 kg) of the explosive is calculated. The tests are conducted for three samples of each tested explosive and the final result is the average of the three values.

Interpretation of the results of the analysis is conducted based on the fact that the concentrations of carbon monoxide (CO) and carbon dioxide (CO<sub>2</sub>) is constant after the initial mixing period (homogenization of the post-detonation gas mixture). Due to the occurrence of consecutive reactions between the detonation products, the initial concentrations of nitrogen oxides (NO, NO<sub>x</sub> and NO<sub>2</sub>) are determined by plotting a dependence of the concentration of each substance over time that has elapsed since detonation and extrapolating the experimental curve to the moment of detonation [30]. The initial concentrations

of post-detonation gases ( $C_G$ ) are used to calculate the quantity of each gas ( $Q_G$ ) at normal conditions (273 K, 760 mm<sub>Hg</sub>) via Equation (2):

$$Q_G = \frac{V_{ch} \cdot 273}{10^6 \cdot m \cdot 760} \cdot \frac{p_1}{T_1} \cdot C_G \left[ \frac{\text{dm}^3}{\text{kg}} \right] \quad (2)$$

where:

- $p_1$ —measured pressure in the chamber after detonation [mm<sub>Hg</sub>]
- $T_1$ —measured temperature in the chamber after detonation [K]
- $V_{ch}$ —volume of the experimental chamber [dm<sup>3</sup>]
- $m$ —mass of the detonated explosive sample [kg]

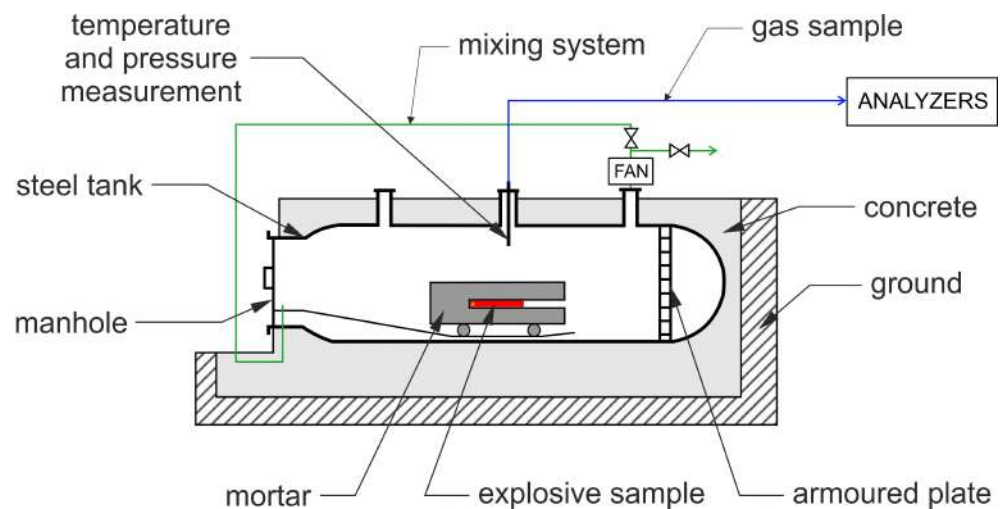

**Figure 3.** Blasting chamber for post-detonation gases analysis (based on [29]).

#### 2.2.8. Determination of Brisance via the Hess Method

A lead cylinder (99.97% purity, diameter  $40 \pm 0.2$  mm, height  $60 \pm 0.15$  mm; face surfaces were machined to 10 grade) was placed vertically on the ground. A cylindrical steel disc (1.7035 steel, diameter  $41 \pm 0.2$  mm, height  $10 \pm 0.2$  mm; face surfaces were machined to 2.5 grade and hardened to 150–200 HB) was placed on top of this cylinder. A set mass (50 g) of the tested sample, loaded into a 3D printed plastic (PET-G) testing cup (inner diameter 40 mm, height 65 mm), was placed onto this plate and initiated, as depicted in Figure 4. This resulted in axial compression of the lead cylinder, with the change in the height of this cylinder being used as a measure of brisance. Similarly to other procedure for the ballistic mortar test, RDX was used as the reference material. The sample was initiated using a standard 0.65 g PETN detonator.

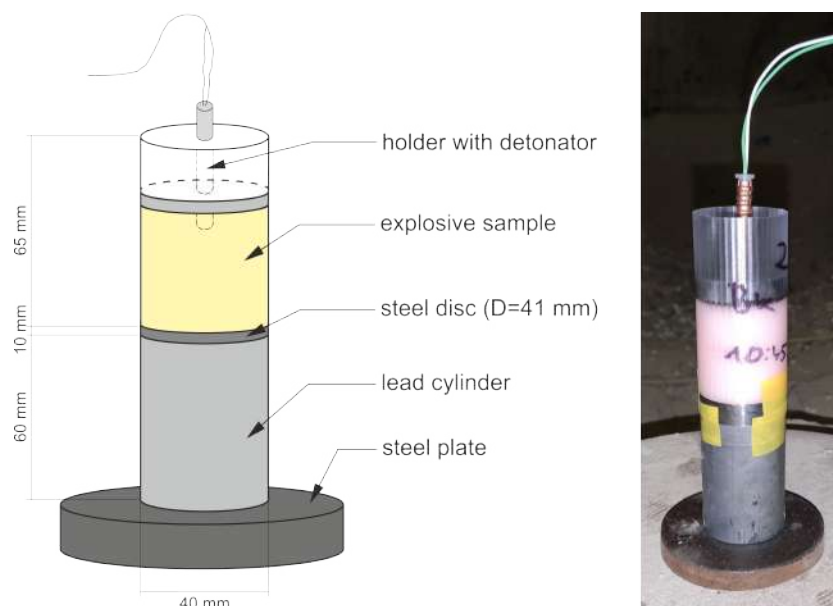

**Figure 4.** Experimental setup for determining brisance using the Hess method.

### 3. Results

#### 3.1. Projected Detonation Parameters

The properties of the EEs utilising the proposed sensitizing agent formulations were predicted theoretically in comparison with the commonly used Emulinit 8L EE, using EXPLO5 software. Although this software is an accurate tool for predicting the fundamental properties and performance parameters of a variety of explosives, based on their composition, it is unable to take into account some physical processes taking place in emulsion explosives, which are non-ideal explosives, such as the precipitation of microscopic grains of ammonium perchlorate in the bulk of the EE.

Despite the above, the software was able to predict that both BK-1 and BK-2 will outperform Emulinit 8L in terms of both velocity of detonation (VoD) and compression energy (Table 2). It is worth noting that the volume of evolving gases for BK-2 is the lowest out of the three EE formulations, despite it showing both the highest detonation pressure and VoD, indicative that the energy contained within this formulation is used significantly more efficiently in its case than in the case of the other two formulations.

**Table 2.** Summary of detonation parameters calculated using EXPLO5 software.

Parameter/Sample	Emulinit 8L	BK-1	BK-2
Density ( $\text{g}/\text{cm}^3$ )	0.85	0.90	0.92
Oxygen balance (%)	0.129	0.356	0.485
Detonation parameters at the C-J point			
Heat of detonation (kJ/kg)	2865	2931	2987
Detonation pressure (GPa)	4.40	4.98	5.24
Velocity of detonation (m/s)	4400	4594	4678
Volume of evolved gases ( $\text{dm}^3/\text{kg}$ )	992	987	983
Compression energy (kJ/kg)	691	725	741

#### 3.2. Changes in Sample Density

The EE samples were sensitised chemically, through a reaction between ammonium nitrate(V) and sodium nitrite(III) that resulted in the gradual evolution of nitrogen gas [31]. In the case of bulk explosives, loaded directly into boreholes, control over the course of this reaction is virtually non-existent after the EE matrix and sensitizing agent are mixed.



Simultaneously, however, the progress of this reaction results in a gradual decrease in EE density, affecting its detonation parameters, which is a significant issue in the planning of blasting operations. Consequently, bulk EEs, which show only a weak dependence of density on time elapsed after loading the EE into boreholes, or whose density quickly stabilises at a quasi-constant level, are highly desirable. The specific time period, in which this density stabilisation should take place, is dependent on the particular application. In the case of underground mining, 30 min are often given as the minimal time elapsed between loading boreholes with bulk EE and carrying out the blasting operation. Hence, this time period was used as a benchmark of comparison between the investigated EE formulations.

In the case of the investigated samples, the “traditional” 8L EE formulation shows an almost linear dependence of density on time elapsed since the sensitizing process began (Figure 5). Although the rate of density changes decreases slightly after approx. 20 min, there is no evidence for the density of the samples stabilising in the investigated time period and the density continues to change rapidly after the benchmark 30 min time period.

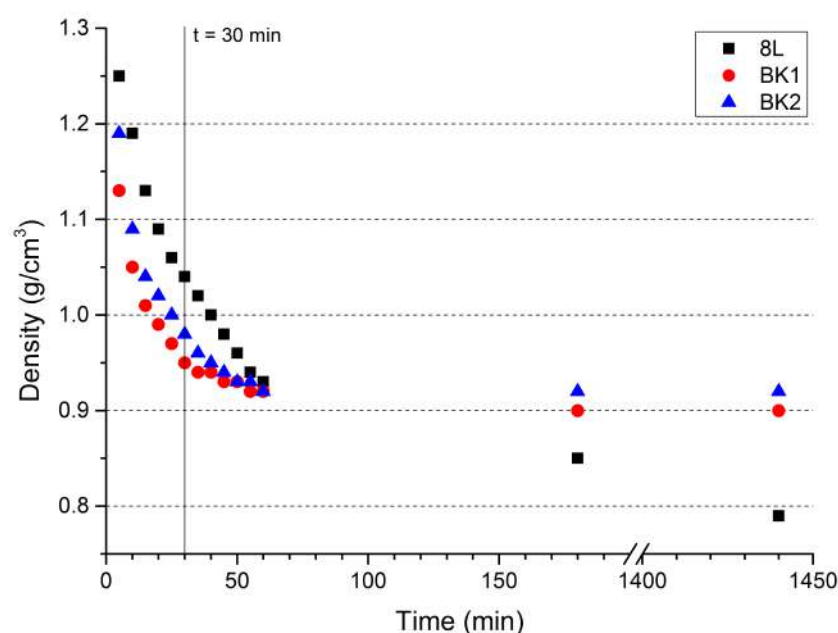

**Figure 5.** Comparison of changes in the density of the EE samples over time.

The two new formulations, BK-1 and BK-2, initially show a much faster density decrease than what is observed for 8L. Unlike 8L, the density of BK-1 and BK-2 formulations quickly begins stabilising, with density changes after 30 min have elapsed being only minor, particularly in the case of BK-1.

The postulated density stabilisation for BK-1 and BK-2 is supported by the fact that the same density values (0.90 and 0.92 g/cm<sup>3</sup>, respectively) are observed after 180 and 1440 min have elapsed, unlike with the 8L sample, whose density continues to decrease (0.85 and 0.79 g/cm<sup>3</sup>, respectively, after 180 and 1440 min have elapsed).

### 3.3. Microscopic Observations

The EE matrix is largely amorphous (Figure 6), with only marginal amounts of crystalline species, originating from crystallisation of the EE matrix on impurities or defects. A similar amount of crystallites is present for Emulinit 8L, with the centre of the micrograph showing a vertically-aligned region with an altered structure, indicating the on-going formation of gas bubbles due to the reaction between the matrix and sensitizing agent used.

In the case of BK-1 and BK-2 (Figure 7), larger crystalline species are present. These species are most likely crystals of ammonium perchlorate that precipitated in the reaction of the highly soluble sodium perchlorate with the concentrated ammonium nitrate solution. Because ammonium perchlorate is an explosive in itself, when the EEs are exposed to a

shock wave, its crystals may promote the formation of additional hot spots. This phenomenon will act in synergy with the evolution of gas bubbles in the EE matrix, further sensitizing the EE sample and facilitating the evolution, propagation and maintaining the detonation wave in the EE.

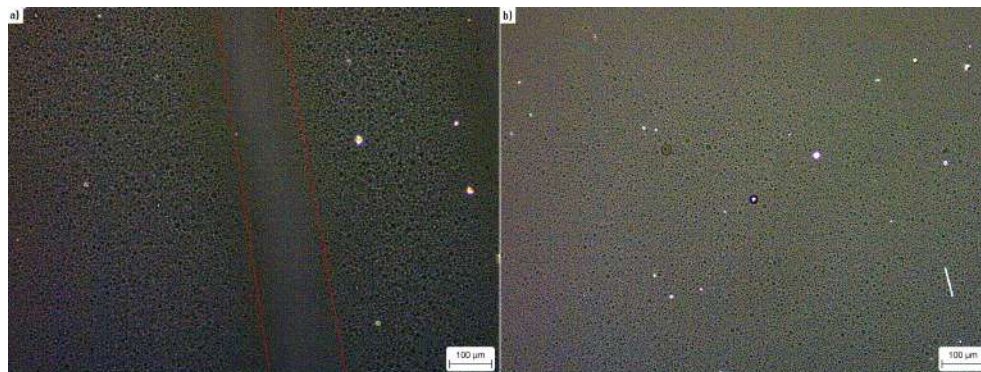

**Figure 6.** Polarised light micrograph of (a) Emulinit 8L; (b) Bulk EE matrix. The diagonal red lines indicate the region, in which sensitizing is on-going.

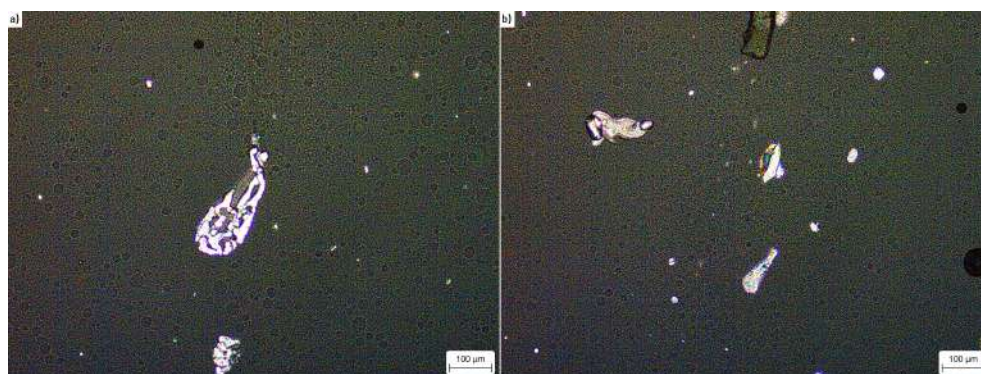

**Figure 7.** Polarised light micrograph of (a) BK-1; (b) BK-2.

### 3.4. Ability to Perform Mechanical Work

In the case of the mechanical work ability test, slightly better results were obtained for BK-1 and BK-2 compositions than for the reference material (Emulinit 8L) due to their higher energy (Table 3). This is due to the fact that there is less water in the composition in favor of the components reacting in an explosive way. A better conversion degree of reaction at a higher detonation velocity gives a higher detonation pressure, which has an impact on the projectile launch capacity.

**Table 3.** Summary of the ability of the tested explosive charges to perform mechanical work.

Explosive	Mortar Inclination Angle [deg]	Relative Ability to Perform Work	Ref.
RDX (reference explosive)	17.20	100%	-
Dynamite	-	84%	[32]
ANFO	-	51%	[32]
TNT (flaked)	14.13	67.7%	-
Emulinit 8L	13.60	62.6%	-
BK-1	14.23	68.8%	-
BK-2	14.33	69.6%	-

### 3.5. Shock Wave Parameters

Very slight variations in the pressure of the blast wave were observed (Table 4). This may be due to a small difference in the detonation temperature. There are no additives, e.g., aluminium, which could increase the explosion temperature and extend the time of impact of the blast wave pressure.

**Table 4.** Summary of the results of air blast parameter tests. Each value given is the of at least three independent measurements.

Explosive	$P_{MAX}$ [kPa] <sup>a</sup>		Duration [ms] <sup>b</sup>		Impulse [Pa · s] <sup>c</sup>	
	$P_{S_{2m}}$ <sup>d</sup>	$P_{S_{2.5m}}$	$P_{S_{2m}}$	$P_{S_{2.5m}}$	$P_{S_{2m}}$	$P_{S_{2.5m}}$
Emulinit 8L	123.73 ± 7.91	73.33 ± 7.02	1.27 ± 0.01	1.46 ± 0.02	57.20 ± 0.89	43.83 ± 0.60
BK-1	127.13 ± 5.67	74.30 ± 1.01	1.26 ± 0.01	1.49 ± 0.04	57.53 ± 0.86	44.37 ± 0.67
BK-2	131.20 ± 6.49	75.93 ± 1.71	1.27 ± 0.01	1.46 ± 0.03	58.60 ± 1.04	44.80 ± 0.26

<sup>a</sup> Peak overpressure recorded during the experiment; <sup>b</sup> Air blast positive phase duration; <sup>c</sup> Air blast total positive phase impulse; <sup>d</sup> Position of the sensor, with the subscript value denoting the distance of the sensor from the axis of the EE sample.

### 3.6. Detonation Velocity

The lower water content in the new formulations causes the velocity of detonation (VoD) to increase (Table 5). Additionally, there is some perchlorates content which improves the propagation of the detonation wave.

**Table 5.** Summary of the results of velocity of detonation measurements.

Explosive	Detonation Velocity [m/s]			
	Sample 1	Sample 2	Sample 3	Average
Emulinit 8L	4220	4270	4210	4233 ± 32
BK-1	4650	4650	4650	4647 ± 6
BK-2	5040	5030	5030	5033 ± 6

### 3.7. Composition of Post-Detonation Gases

Due to the better distribution of hot spots and a certain content of ammonium perchlorate microcrystals, compositions BK-1 and BK-2 are characterized by better detonation and better conversion of reagents. Especially in the case of the BK-1 composition, the conversion rate causes the fuel oxidation reaction to trend towards the formation of carbon dioxide and water. As a result, the amount of harmful gases is partially reduced (Table 6).

**Table 6.** Summary of the average composition of post-detonation gases for the tested explosives.

Emulinit 8L	CO <sub>2</sub>	CO	NO <sub>2</sub>	NO
Concentration [ppm]	4583 ± 45	162 ± 11	1.4 ± 0.2	20.0 ± 7.4
Unit mass emission [dm <sup>3</sup> /kg]	114.8 ± 1.1	4.11 ± 0.28	0.04 ± 0.01	0.51 ± 0.19
BK-1	CO <sub>2</sub>	CO	NO <sub>2</sub>	NO
Concentration [ppm]	4664 ± 6	100 ± 4	1.5 ± 0.2	11.6 ± 2.8
Unit mass emission [dm <sup>3</sup> /kg]	117.1 ± 0.9	2.51 ± 0.12	0.04 ± 0.01	0.29 ± 0.07
BK-2	CO <sub>2</sub>	CO	NO <sub>2</sub>	NO
Concentration [ppm]	4553 ± 24	136 ± 18	1.2 ± 0.2	11.0 ± 5.3
Unit mass emission [dm <sup>3</sup> /kg]	115.3 ± 0.4	3.45 ± 0.46	0.03 ± 0.01	0.28 ± 0.13

### 3.8. Investigation of Brisance

Brisance is directly dependent on the velocity of detonation. It is a measure of the effect of pressure on objects closest to the explosive. It is especially visible in the case of

the BK-2 composition, because in a similar density range the detonation velocity is much higher than for the reference material (Figure 8).

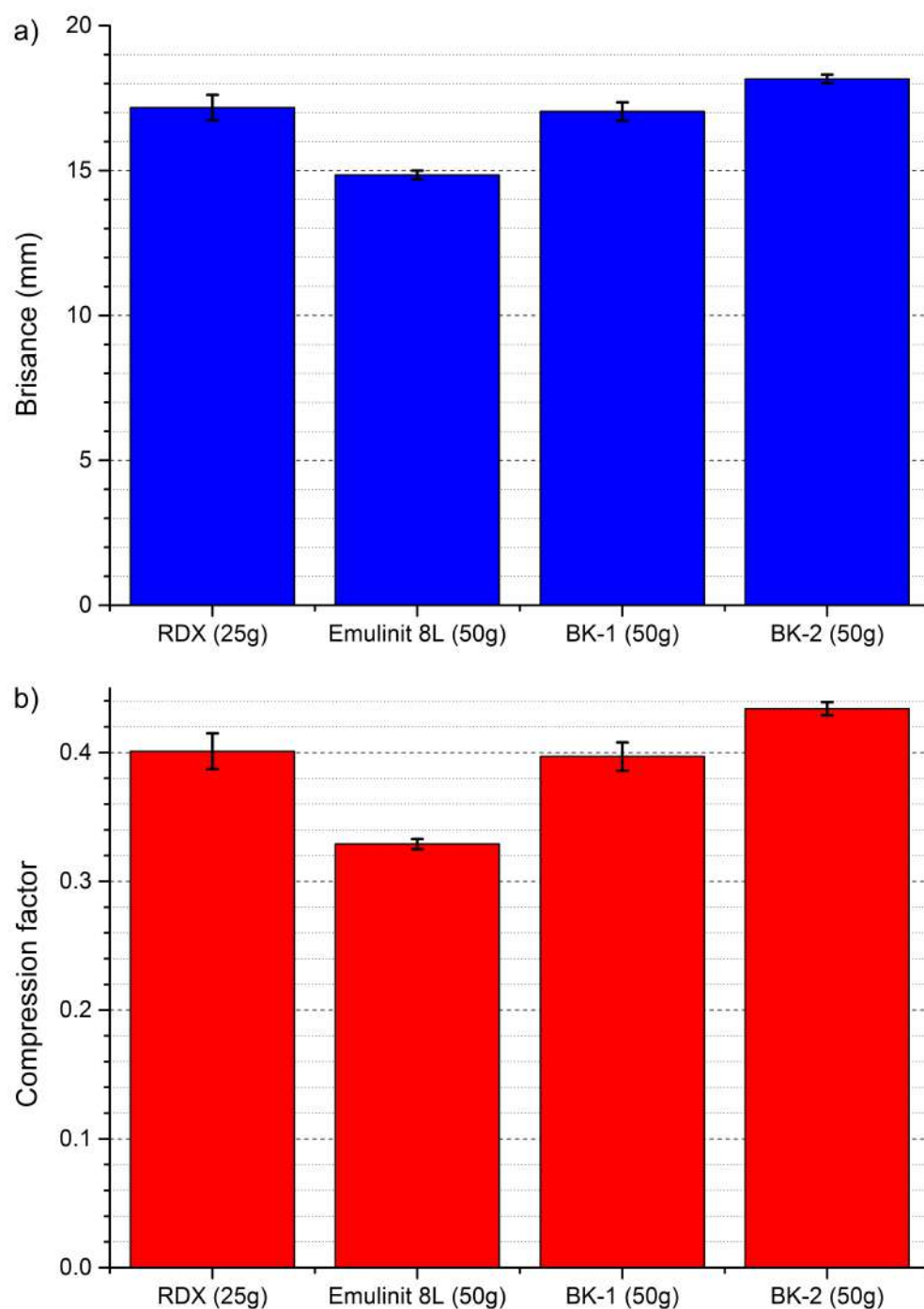

**Figure 8.** Comparison of (a) brisance and (b) compression factors determined for the tested EE samples and reference explosive (RDX) using the Hess test.

#### 4. Discussion

The results of the research showed that the parameters of the new BK-1 and BK-2 formulas were better in every aspect compared to the standard, commercially used Emulinit 8L emulsion explosive. In addition, the performance of BK-1 and BK-2 exceeded theoretical predictions collated with the use of EXPLO5 software. This is likely due to the precipitation of ammonium perchlorate crystals (Figure 7) in the bulk of the BK-1 and BK-2 EEs that were

not present in the case of Emulinit 8L (Figure 6). These crystals are hypothesised to act as additional “hot spots”, further sensitizing the explosives and facilitating their detonation.

The inclusion of sodium perchlorate in the EE formulations (Table 1) is an interesting matter in terms of material safety. Supplementing the EE matrix with perchlorates would be a source of risk due to its processing at elevated temperatures [20]. Hence, we have opted to include sodium perchlorate in the sensitising agent formulation, as it consists primarily of water and even with the inclusion of sodium perchlorate, it remains classified as an oxidising solution. Mixing the EE matrix with the sensitizing agent formulation, upon loading the EE formulation into boreholes, results in the in situ precipitation of ammonium perchlorate. Even though this process is expected to increase the sensitivity of BK-1 and BK-2 formulations to initiating stimuli, it does not translate into any significant increase of risk. This is due to the fact that once the EE is loaded into boreholes, it is protected from virtually all sources of accidental initiation.

The sensitization of the tested formulations is much faster and more stable, so the temperature of the components does not have such a significant influence on the reaction rate. In standard conditions of underground mines (at temperatures in the range of 25–35 °C), it is capable of detonation after 5 min and the final density is obtained after approx. 30 min, while the standard reference material in these conditions is capable of reliable detonation after 30 min at the very least and achieves its final density only after more than 12 h. This aspect is very important in practice, because the temperature conditions in underground mines can vary significantly between different locations. Simultaneously, procedures employed in blasting may involve various time intervals between loading the boreholes and initiation of the explosive charges. Consequently, an explosive, whose performance changes only marginally with time or environment temperature, is both much more predictable and desirable for use than one, whose performance varies significantly.

In terms of the relative ability to perform mechanical work (Table 3), the BK-1 and BK-2 formulations achieved noticeably higher performance than Emulinit 8L and were even comparable to the performance of TNT.

Despite the current research focus on supplementing EEs with a variety of additives, the efficacy of such supplementation has its limitations, particularly since the additives are introduced only in limited amounts. This is illustrated well by considering the blast wave parameters that would be expected for the three types of EE formulation samples. The blast wave parameters are strongly tied to the detonation temperature and volume of gases evolving in the decomposition of a unit mass of the EE formulation. These parameters, in turn, are determined to a much greater extent by the chemical composition of the EE formulation rather than by its physical state. Consequently, even if the composition of the sensitizing phase, which constitutes less than 5 wt. % of the formulation, is changed significantly, as has been implemented for BK-1 and BK-2, in comparison with Emulinit 8L, the composition of the entire formulation is changed only to a small extent. Consequently, it is expected that those parameters will be similar for all three EE formulations, even though a very slight elevation of those parameters was observed for BK-1 and BK-2 in comparison with Emulinit 8L (Table 4).

Conversely, the brisance and velocity of detonation (VoD) are influenced to a much greater degree by physical factors than blast wave parameters. In this aspect, the introduction of a modified sensitizing phase yields the most outstanding improvement, with the brisance of BK-1 and BK-2 increasing by 20.67% and 31.91%, respectively, in comparison with Emulinit 8L (Figure 8). Simultaneously, the VoD was observed as 9.8% and 18.9% greater for BK-1 and BK-2, respectively, than for Emulinit 8L.

In the case of the BK-1 and BK-2 formulations, blasting fumes have a lower content of toxic gases compared to the standard formula. This is due to a better conversion rate and more perfect reaction during detonation. Summarizing the results new formulas of explosives are characterized by a greater efficiency of the explosive transformation, a more controlled and faster sensitization reaction and a more favorable composition of blasting fumes. The first tests under operating conditions were also carried out. The resulting

explosive is capable of working properly. The obtained results require confirmation in subsequent tests carried out under operating conditions, the aim of which will be to improve the performance of the formulations via optimising the process of mixing components, which should confirm the results and conclusions obtained in laboratory conditions. In fact, the price of the new explosive bulk emulsion will be higher, but it is expected to allow carrying out blasting works in a wider range of conditions. The increased brisance of the two formulations is also expected to facilitate the use of EEs in the exploitation of hard rocks.

## 5. Conclusions

Based on the presented experimental results, we can conclude that the modified sensitizing agent formulations are an all-round improvement in comparison to the traditional formulation used for Emulinit 8L. Although the performance of BK-1 was slightly inferior to that of BK-2, the sensitizing agent formulation contains approx. 20 wt. % more water than the one used for BK-2 (Table 1). This translates directly to BK-1 having a lesser unit cost than BK-2, while affording better performance than Emulinit 8L. Consequently, we envision BK-1 to serve as the general replacement for Emulinit 8L, while BK-2 may be used for more specialised applications and with some further optimisation will have the potential to serve as a replacement for nitroester-based explosives (e.g., dynamites) due to its high relative ability to perform mechanical work (Table 3), velocity of detonation (Table 5) and brisance (Figure 8).

The optimisation of the two formulations can also be targeted at fine-tuning the sensitizing agent composition to further shorten the sensitising time of the explosives and to further promote their ability to perform mechanical work. Regardless of optimisation pathway, both types of the BK EE formulations are promising energetic materials with broad future applications, possibly setting a new direction for development in the field of modern emulsion explosives.

**Author Contributions:** Conceptualization, B.K.; Methodology, B.K., M.P., P.M., T.J.; Validation, B.K., T.J., K.J.; Investigation, B.K., M.P., P.M.; Data curation, B.K., P.M., T.J.; Writing—original draft preparation, B.K., M.P., P.M., T.J.; Writing—review and editing, T.J., K.J.; Visualization, B.K., P.M., M.P., T.J.; Supervision, B.K., T.J.; Funding acquisition, T.J., K.J. All authors have read and agreed to the published version of the manuscript.

**Funding:** The Authors acknowledge the support of the Silesian University of Technology project no. 04/040/BK\_21/0145. T.J. gracefully acknowledges the scientific and innovative merit grant no. 04/040/RGJ22/0201 of the Rector of the Silesian University of Technology.

**Institutional Review Board Statement:** Not applicable.

**Informed Consent Statement:** Not applicable.

**Data Availability Statement:** Data is available on request from any of the Authors.

**Acknowledgments:** The authors would like to sincerely thank OZM Research s.r.o. and Forcepol Sp. z o.o. for providing the EXPLO5 software for calculating detonation parameters.

**Conflicts of Interest:** The authors declare no conflict of interest.

## Appendix A. Velocity of Detonation—Sample Experimental Plot

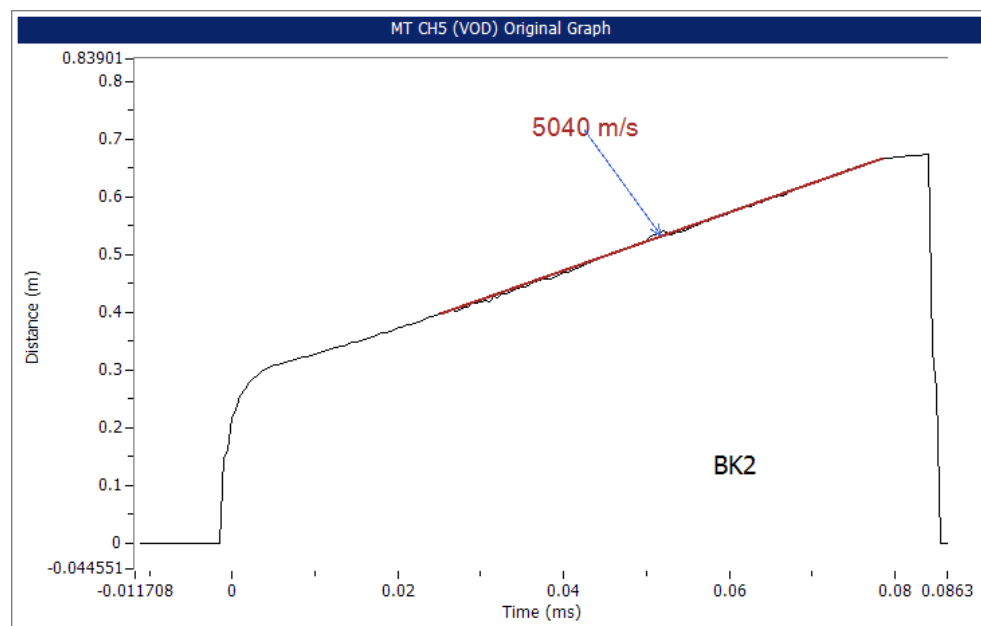

**Figure A1.** Sample distance vs. time curve, from which the velocity of detonation for the BK2 EE formulation was determined graphically.

## References

1. Tag, A.; Petterson, B.R.; Nygaard, E.C. Emulsion Explosive. U.S. Patent 4,500,369, 19 February 1985.
2. Yates, D.E.; Dack, S.W. Emulsion Explosive Composition. U.S. Patent 4,710,248, 1 December 1987.
3. Chattopadhyay, A.K. Emulsion Explosive. U.S. Patent 5,500,062, 19 March 1996.
4. Zhao, H.R.; Wu, J.; Xu, M.X.; Zhang, K.M. Advances in the rheology of emulsion explosive. *J. Mol. Liq.* **2021**, *336*, 116854. [[CrossRef](#)]
5. Zhou, J.; Wang, X.; Gong, M.; Zhao, M. The effect of surfactant on the rheology and stability properties of emulsion explosive matrices. *J. Dispers. Sci. Technol.* **2021**, 1–9. [[CrossRef](#)]
6. Fang, H.; Cheng, Y.F.; Tao, C.; Su, H.; Gong, Y.; Chen, Y.; Shen, Z.W. Effects of content and particle size of cenospheres on the detonation characteristics of emulsion explosive. *J. Energetic Mater.* **2021**, *39*, 197–214. [[CrossRef](#)]
7. Yao, Y.L.; Cheng, Y.F.; Zhang, Q.W.; Xia, Y.; Hu, F.F.; Wang, Q.; Chen, Y. Explosion Temperature Mapping of Emulsion Explosives Containing TiH<sub>2</sub> Powders with the Two-color Pyrometer Technique. *Def. Technol.* **2021**, *in press*. [[CrossRef](#)]
8. Yao, Y.L.; Cheng, Y.F.; Liu, R.; Hu, F.F.; Zhang, Q.W.; Xia, Y.; Chen, Y. Effects of Micro-Encapsulation Treatment on the Thermal Safety of High Energy Emulsion Explosives with Boron Powders. *Propellants Explos. Pyrotech.* **2021**, *46*, 389–397. [[CrossRef](#)]
9. Stanković, S.; Škrlec, V.; Dobrilović, M.; Bohanek, V. Velocity of detonation of AN base blasting agent with addition of hay and recycled rubber. *New Trends Res. Energ. Mater.* **2018**, *2018*, 1042–1050.
10. Ospanov, S.; Ospanova, R.; Kerimbekova, Z.; Zhumatayeva, S. Explosive Substances with Powder of Emulsion Mixture Samples to Test on Polygon. In *Industrial Technologies and Engineering (ICITE-2017)*; M. Auezov South Kazakhstan State University: Shymkent, Kazakhstan, 2017; pp. 349–352.
11. Němec, O.; Jungová, M.; Mareček, R.; Novotný, M.; Zeman, S.; Šelešovský, J. Fortification of W/O emulsions by demilitarized explosives. Part I. Use of TNT. *Cent. Eur. J. Energetic Mater.* **2011**, *8*, 193–207.
12. Yang, M.; Ma, H.; Shen, Z. Effect of RDX powders on detonation characteristics of emulsion explosives. *J. Energetic Mater.* **2019**, *37*, 459–474. [[CrossRef](#)]
13. Biegańska, J. Using nitrocellulose powder in emulsion explosives. *Combust. Explos. Shock Waves* **2011**, *47*, 366–368. [[CrossRef](#)]
14. Renick, J.; Sanchez, J. *Detonation Characteristics of Mixtures of HMX and Emulsion Explosives*; Technical Report; Air Force Weapons Lab Kirtland Afb Nm: Fort Belvoir, VA, USA, 1989.
15. Mei, Z.; Qian, H.; Liu, D.; YE, Z.W.; Lü, C.x. Preparation of emulsion explosive for military-civil. *Chin. J. Explos. Propellants* **2012**, *35*, 32–34.
16. Lownds, C.M. Emulsified Gassing Agents Containing Hydrogen Peroxide and Methods for Their Use. U.S. Patent 5,397,399, 14 March 1995.
17. Araos, M.; Onederra, I. Detonation characteristics of a NO<sub>x</sub>-free mining explosive based on sensitised mixtures of low concentration hydrogen peroxide and fuel. *Cent. Eur. J. Energetic Mater.* **2017**, *14*, 759–774. [[CrossRef](#)]

18. Cheng, Y.F.; Ma, H.H.; Shen, Z.W. Detonation characteristics of emulsion explosives sensitized by MgH<sub>2</sub>. *Combust. Explos. Shock Waves* **2013**, *49*, 614–619. [[CrossRef](#)]
19. Cheng, Y.F.; Meng, X.R.; Feng, C.T.; Wang, Q.; Wu, S.S.; Ma, H.H.; Shen, Z.W. The effect of the hydrogen containing material TiH<sub>2</sub> on the detonation characteristics of emulsion explosives. *Propellants Explos. Pyrotech.* **2017**, *42*, 585–591. [[CrossRef](#)]
20. Wade, C.G. Cap Sensitive Emulsions Containing Perchlorates and Occluded Air and Method. U.S. Patent 4,149,916, 17 April 1979.
21. Kramarczyk, B.; Pytlik, M.; Mertuszka, P. Effect of aluminium additives on selected detonation parameters of a bulk emulsion explosive. *Mater. Wysokoenergetyczne* **2020**, *12*, 99–113. [[CrossRef](#)]
22. Agrawal, H.; Mishra, A.K. A study on influence of density and viscosity of emulsion explosive on its detonation velocity. *Model. Meas. Control C* **2018**, *78*, 316–336. [[CrossRef](#)]
23. Yunoshev, A.; Plastinin, A.; Sil'vestrov, V. Effect of the density of an emulsion explosive on the reaction zone width. *Combust. Explos. Shock Waves* **2012**, *48*, 319–327. [[CrossRef](#)]
24. United Nations Economic Commission for Europe. *European Agreement Concerning the International Carriage of Dangerous Goods by Road (ADR)*; United Nations Economic Commission for Europe: Geneva, Switzerland, 2021; ISBN 978-92-1-139179-4.
25. Mertuszka, P.; Kramarczyk, B. The impact of time on the detonation capacity of bulk emulsion explosives based on Emulinit 8L. *Propellants Explos. Pyrotech.* **2018**, *43*, 799–804. [[CrossRef](#)]
26. Trzeciński, W.A.; Szymańczyk, L.; Kramarczyk, B. Determination of the Equation of State for the Detonation Products of Emulsion Explosives. *Cent. Eur. J. Energetic Mater.* **2019**, *16*. [[CrossRef](#)]
27. Baranowski, P.; Mazurkiewicz, Ł.; Małachowski, J.; Pytlik, M. Experimental testing and numerical simulations of blast-induced fracture of dolomite rock. *Meccanica* **2020**, *55*, 2337–2352. [[CrossRef](#)]
28. Baranowski, P.; Kuciewicz, M.; Gieleta, R.; Stankiewicz, M.; Konarzewski, M.; Bogusz, P.; Pytlik, M.; Małachowski, J. Fracture and fragmentation of dolomite rock using the JH-2 constitutive model: Parameter determination, experiments and simulations. *Int. J. Impact Eng.* **2020**, *140*, 103543. [[CrossRef](#)]
29. Zawadzka-Małota, I. Testing of mining explosives with regard to the content of carbon oxides and nitrogen oxides in their detonation products. *J. Sustain. Min.* **2015**, *14*, 173–178. [[CrossRef](#)]
30. Biessikirski, A.; Gotovac Atlagić, S.; Pytlik, M.; Kuterasiński, Ł.; Dworzak, M.; Twardosz, M.; Nowak-Senderowska, D.; Napruszewska, B.D. The Influence of Microstructured Charcoal Additive on ANFO's Properties. *Energies* **2021**, *14*, 4354. [[CrossRef](#)]
31. Kramarczyk, B.; Mertuszka, P. Study of Influence of Sensitizer Content on Density of Bulk Emulsion Explosive Used in Underground Operations. *Cent. Eur. J. Energetic Mater.* **2021**, *18*, 429–447.
32. Szastok, M. Comparative study of anfo's and dynamite's capability to perform work determined with lead block and ballistic pendulum. *Zesz. Nauk. Inst. Gospod. Surowcami Miner. Pol. Akad. Nauk.* **2018**, 75–90. [[CrossRef](#)]



## Article

# Implementation and Verification of Effectiveness of Bulk Emulsion Explosive with Improved Energetic Parameters in an Underground Mine Environment

Piotr Mertuszka <sup>1,\*</sup>, Bartłomiej Kramarczyk <sup>2</sup>, Mateusz Pytlik <sup>3</sup>, Marcin Szumny <sup>1</sup>, Katarzyna Jaszcz <sup>4</sup> and Tomasz Jarosz <sup>4,\*</sup>

<sup>1</sup> KGHM Cuprum Ltd. Research & Development Centre, 2-8 Sikorskiego Street, 53-659 Wrocław, Poland

<sup>2</sup> NITROERG S.A., 1 Alfred Nobel Square, 43-150 Bieruń, Poland

<sup>3</sup> Conformity Assessment Body, Central Mining Institute, 1 Gwarków Square, 40-166 Katowice, Poland

<sup>4</sup> Department of Physical Chemistry and Technology of Polymers, Silesian University of Technology, 44-100 Gliwice, Poland

\* Correspondence: piotr.mertuszka@kghmcuprum.com (P.M.); tomasz.jarosz@opayq.com (T.J.)

**Abstract:** Explosives are commonly used in the mining industry to extract minerals from hard rock deposits. Therefore, an efficient explosive should ensure that the appropriate blast outcome is achieved, taking into account the desired rock-breaking parameters and the costs of drilling and blasting works. Depending on the type of deposit and follow-up processes, a proper blast result may be characterized by fragmentation, muckpile shape, overbreaks, etc. Industry has struggled to respond to the demand for bulk emulsion explosives with improved energetic parameters, having so far been unable to do so safely, effectively, and cost-efficiently. Methods of improving blasting parameters mainly rely on introducing a variety of additives to the emulsion explosive formulation during production, which creates additional hazards at that stage. Alternative, safe methods of achieving an improved energetic performance of emulsion explosives are, therefore, highly desirable. This paper is focused on one such proposed method as a continuation of previous research works and the performance of a novel bulk emulsion formulation under real mining conditions during the firing of mine faces is described. The tests included density measurements over time, measurements of impact and friction sensitivity, measurements of the detonation velocity in blastholes, determination of brisance via Hess test, and analysis of rock fragmentation. Results were compared with those obtained with a commercially available bulk emulsion explosive, highlighting that the performance improvement achieved by the proposed emulsion modification method is not limited to artificial test conditions, but translates well into actual application conditions.

**Keywords:** underground mining; blasting; explosives; detonation velocity

**Citation:** Mertuszka, P.; Kramarczyk, B.; Pytlik, M.; Szumny, M.; Jaszcz, K.; Jarosz, T. Implementation and Verification of Effectiveness of Bulk Emulsion Explosive with Improved Energetic Parameters in an Underground Mine Environment. *Energies* **2022**, *15*, 6424. <https://doi.org/10.3390/en15176424>

Academic Editor: Krzysztof Skrzypkowski

Received: 31 July 2022

Accepted: 26 August 2022

Published: 2 September 2022

**Publisher's Note:** MDPI stays neutral with regard to jurisdictional claims in published maps and institutional affiliations.



**Copyright:** © 2022 by the authors. Licensee MDPI, Basel, Switzerland. This article is an open access article distributed under the terms and conditions of the Creative Commons Attribution (CC BY) license (<https://creativecommons.org/licenses/by/4.0/>).

## 1. Introduction

The growing demand for metals and minerals translates into the need for economically sound, effective, time- and material-efficient methods of mining. However, there are still some technical constraints associated with underground mining. Over the last few decades, the development of mining explosives has led to a continuous improvement in their energetic parameters while maintaining the highest effectiveness and safety of blasting operations. Emulsion explosives, frequently referred to as “the latest generation explosives”, are a prime example of this trend, even though they were invented more than 50 years ago [1]. According to the data provided by the Federation of Explosives Manufacturers, the share of bulk emulsion explosives in the total usage of emulsions in Europe is more than 85%, with this share expected to increase even further in the

coming years. This is mainly because no alternative methods of solid rock extraction have so far proven to be effective enough [2,3].

The mining industry is facing various challenges, such as the need for increased production, reducing the time of the entire technological cycle, lowering deposit exploitation costs and ensuring personnel safety, including the issue of the stability of underground openings [4,5]. One such challenge, related to drilling and blasting operations, is the general effectiveness of blasting, mainly in terms of explosive performance. The effect of blasting is directly influenced by the working capacity of explosives—which, in a much wider sense, may be defined as the quality of explosives. It should, however, be noted that, apart from a number of manufacturing parameters which influence the working capacity [6,7], the results of blasting are affected by many different technological parameters. They are only observed in real mining conditions and cannot be evaluated under laboratory conditions [8,9]. The most important factors from the adopted technology point of view are the diameter of the blastholes, method of initiation or time between charging of explosives, and firing.

According to recent studies [10], the detonation velocity increases with an increase in blasthole diameter. Velocity of detonation (VOD) is used as a basic parameter in the determination of the detonation pressure, which in turn represents the energy of the explosive [11,12]. The problem of the blasthole diameter is especially significant when high rock pressures are observed. This may lead to a reduction in blasthole diameters, while causing a reduction in the charge diameter, but may also cause some problems with charging (when using bulk emulsions). The initiation method in turn is important for the effectiveness of the production. When initiating with the detonator only, the distance between the detonator position and the stable detonation velocity value is much greater than when using proper boosters. However, according to previous research studies, this does not affect the final detonation velocity value of bulk emulsions [13] but may affect the VOD of ANFO explosives [14]. From a safety point of view, the time between charging the blastholes and firing seems to be the most important factor. This problem should be considered from two perspectives. The first is associated with the density changes in time, which means that detonation velocity decreases with reductions in density. Such an explosive becomes less energetic over time [15,16]. The second problem is connected with the sleep time of bulk emulsions [17]. The sleep time is the time after which the bulk emulsion loses its detonation capacity. As shown during field investigations, the sleep time may even reach 6 months after the charging [18], meaning that each undetonated explosive should be treated with extreme caution.

Other important factors that may only be observed in underground mines are the temperature of rock mass and ambient temperature. With the increase in depth, the primary rock mass temperature increases. Under such conditions, lower thermodynamic parameters of bulk emulsions may be expected and their efficiency, expressed as velocity of detonation, may be much lower [19,20]. A very important issue in the field of blasting effectiveness is also detailed identification of the interaction between the explosive and the rock mass, i.e., propagation of blast-induced fractures around the blasthole [21,22]. This should be treated as the first step in the selection of relevant explosives for given geologic and mining conditions. Therefore, it may be concluded that the determination of relationships between the above parameters and their efficiency is critical in formulating reliable and credible computational models describing the detonation process [23].

A recent study was conducted to develop and evaluate, under laboratory conditions, a novel sensitizing agent formulation for bulk emulsion explosives with improved energetic parameters [24]. The purpose of the study was to improve the effectiveness of blasting by replacing the commonly used sensitizer by novel formulations. The results proved that energetic parameters of new formulas were actually better in every aspect in relation to the standard explosive, used commercially. The greatest advantage is that the sensitization process is much faster and much more stable. Moreover, it was confirmed

that new formulations are capable of detonation after 5 min and the final density remains stable after 30 min.

Since the mixing of components using mixing–charging units in mines is not as precise as manual mixing in laboratory conditions [25], the authors have made an attempt to verify selected detonation parameters under real mining conditions. For this purpose, one of the developed formulas was verified during regular faces firing and compared with the standard bulk emulsion. Finally, the effectiveness evaluation of such an emulsion was conducted. The tests included: density measurements over time, measurements of the detonation velocity in blastholes, determination of brisance via Hess test, and analysis of blasted rock fragmentation. In this paper, results of in situ trials using the underground mixing–charging units are presented, which should be treated as the continuation of work under development of a novel formulation of bulk emulsion explosive with improved energetic parameters.

## 2. Materials and Methods

Evaluation of the blasting effect has been conducted under real mining conditions in a deep mine in Poland and consisted of two rounds of trials, in each of which explosives in four faces were fired. Each trial included the firing of two faces charged with BK-2 and two with the commercially available E8L explosive for reference. The time interval between the two rounds of trials was two weeks.

### 2.1. Trial Site

A trial panel was located in a deep underground copper mine in Poland, in which the room-and-pillar mining method with roof deflection and pillar softening is practiced. The average depth of excavations is approximately 800 m below the surface. The orebody thickness does not exceed 1.8 m and is almost flat. It is formed from sandstone (2.8 m) and a thin shale stratum located near the roof (Figure 1).

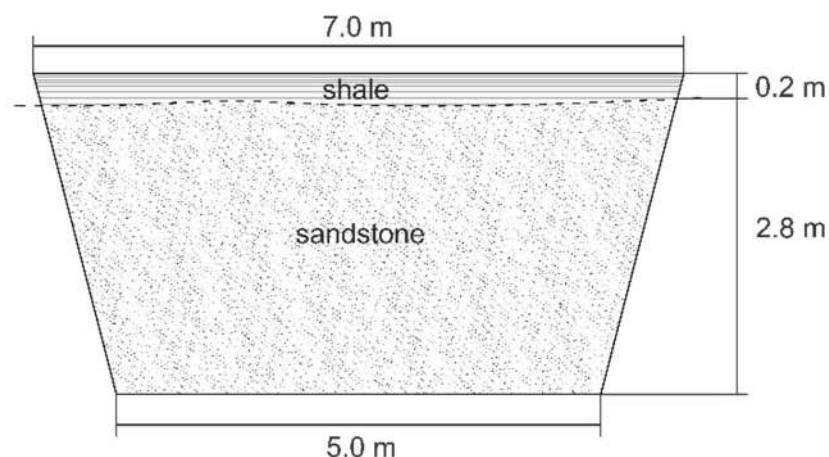
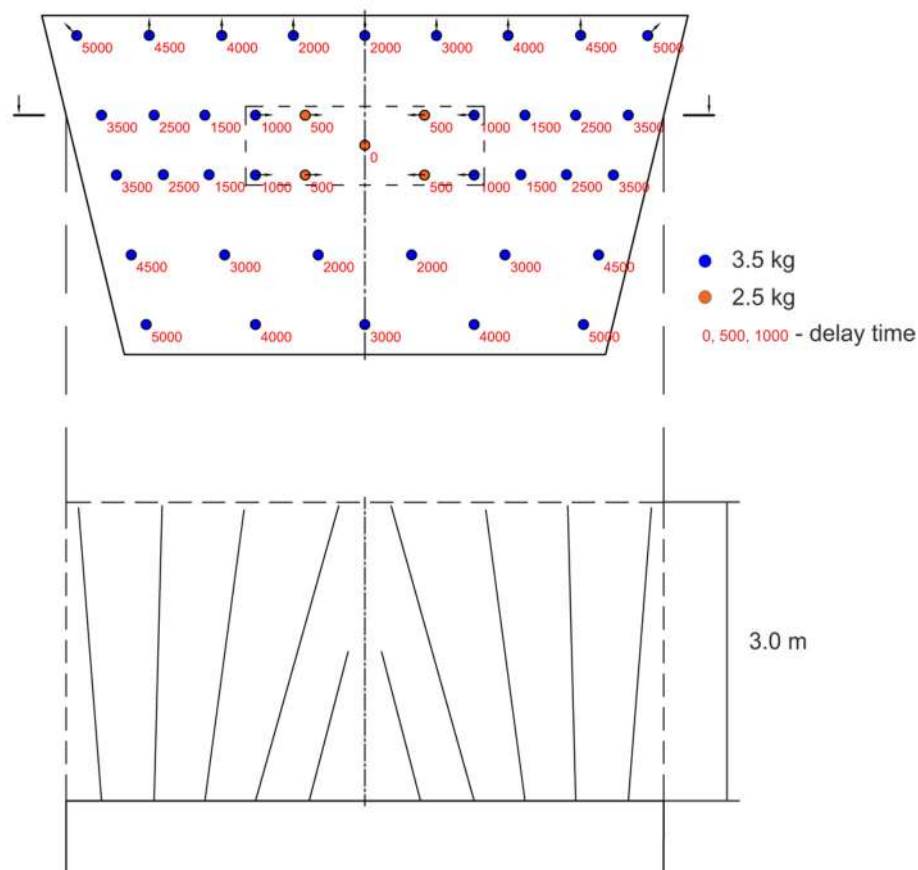

**Figure 1.** Scheme of the mining face cross-section, depicting the geologic structure and dimensions of the typical face over the considered panel.

Drifts are excavated using the drilling and blasting method. The shape of excavations is in the form of an inverted trapezoid, with the average base of 5 m and an average width of 7 m in the roof stratum. The height is approximately 3 m. Faces are fired using bulk emulsion explosives charged by standardized mixing–charging units installed on blasting utility vehicles. Explosives are initiated by non-electric detonators and explosive boosters. No stemming is used in blastholes.

The same drilling and blasting pattern with the V-cut was used on each trial and each face (same distribution of blastholes, same mass of explosives, same delays, etc.), as presented in Figure 2. The blastholes had a length of 3 m, except those charged with 2.5 kg of explosives (central ones), which were slightly shorter, and a diameter of 48 mm;

thus, 3 m was also the expected advance per blast. The total number of blastholes was 41 per face, total mass of explosives per face was 138.5 kg, and the total firing time was 5000 ms. The calculated powder factor was 2.40 kg/m<sup>3</sup>.



**Figure 2.** Drilling and blasting pattern used during underground trials: cross-section of the face (**upper**), topside view of the drilled blastholes (**lower**).

## 2.2. Formulations of Explosives and Mixing–Charging Unit

All tests, except the impact and friction sensitivity tests, were performed on the same batch of emulsion matrix (supplied by Nitroerg) for the underground bulk emulsion formula. The matrix contains ammonium nitrate, calcium nitrate, water, oil, emulsifier, and auxiliary components. The E8L emulsion was sensitized with a standard sensitizing agent—an aqueous solution of sodium nitrite. For the modified BK-2 formulation, a more comprehensive sensitizing agent formulation was utilized, as per the authors' earlier work [24], characterized by a lower water concentration (Table 1).

**Table 1.** Tested sensitizing agent formulations.

Component	Concentration (wt.%)	
	E8L	BK-2
Ammonium nitrate	–	47
Water	95.45	41
Sodium perchlorate	–	8
Sodium nitrate	4.5	3.3
ph modifier and dye	0.05	0.7

The mixing–charging unit was installed on a blasting utility vehicle. It mainly consists of the matrix and sensitizer tanks and pumps for the transfer of these components (Figure 3). The production unit is controlled by a computer for accurate dosing of ingredients. The mixing takes place in the middle of the loading hose, using a static mixer (Figure 4). Former constructions were based on a single mixer, while new ones already have a double static mixer.

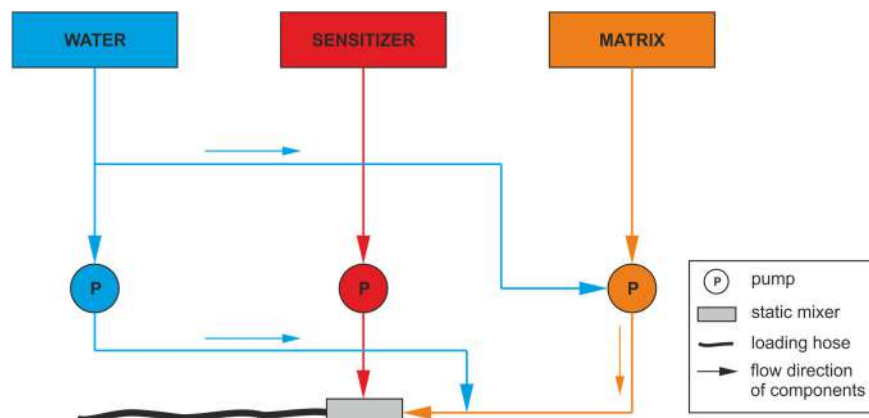

**Figure 3.** Simplified scheme of the mixing–charging units for bulk emulsions. Arrows indicate flow direction of the components.



**Figure 4.** Photographs of the single (**left**) and double (**right**) static mixers.

The flow of components in the loading hose is laminar, thus, the mixing takes place using a cross-stream static mixer. However, due to large differences in the viscosity of components, the fast flow, and relatively short mixing time limited by the length of the static mixer, complete mixing is not possible, compared with manual mixing under laboratory conditions. Thus, in order to investigate the significance of this aspect for the first and second rounds of trials, a single mixer and a double mixer were employed, respectively.

### 2.3. Auxiliary Materials and Software

The probes used for the determination of detonation velocity were manufactured by MREL (Kingston, Canada). They were VOD ProbeCables green with a unit resistance of  $10.80 \Omega/\text{m}$ . Dedicated software, DAS—Data Acquisition Suite, was used for data analysis from the VOD recorder.

Fragmentation analysis was carried out using WipFrag software, version 3.2.11.1, developed by WipWare (North Bay, ON, Canada). Photos of the muckpile after firing were taken using an Olympus Tough TG-6 camera (resolution 12 megapixels, lens aperture  $f/2.0$ ) dedicated for extreme environments.

Statistical analyses were conducted using Statistica 13 software developed by StatSoft (Kraków, Poland).

#### 2.4. Preparation of Explosive Samples and Charging of Blastholes

The explosive components were blended mechanically via standardized mixing–charging units used for charging blastholes in the mine hosting the study. In the case of the BK-2 formulation, the dosing settings of the sensitizer have been reduced by 3.5% due to much greater reaction activity.

Blastholes were loaded following a standard procedure, using the charging hose with 3.5 kg of bulk emulsion, except the cut holes, into which 2.5 kg were loaded. Due to the bottom initiation, the VOD in blastholes could be measured. The average length of the explosive column was 130–140 cm.

During the blastholes charging, the samples for the density measurements and brisance determination were loaded from the mixing–charging unit to the piping bag and then were carefully elaborated into the relevant plastic cups. For this purpose, a precise mobile digital balance was used.

The samples for the impact and friction sensitivity tests in turn were produced by the manual mixing of components, due to the relatively small mass of the sample required for such tests—the sample volume was insufficient for the use of a mechanical stirrer. After mixing, 10 mg samples were accurately weighed. The tests were conducted after the density had stabilized.

#### 2.5. Measurements of the Density over Time

Plastic cups with a set volume of 500 cm<sup>3</sup> were used for the determination of density changes over time. They were weighed and filled with the mixture of the matrix and sensitizer directly from the mixing–charging unit. Due to the chemical reaction (sensitization), the mixture increased in volume, thus, the excess was removed from the top edge of the cup to maintain the set volume of the samples, followed by weighing of the cup. Each sample was weighed using an electronic balance, first at 5 min intervals for 60 min and then once each after 180 min and 1440 min. The density was determined based on the ratio of the net sample mass to the cup volume.

#### 2.6. Determination of the Detonation Velocity

Detonation velocity values were obtained using the electrical method, via the continuous resistance wire technique. In this method, a precise measuring probe of known linear resistance is placed axially in the explosive column. When the detonation front progresses, the probe is destroyed, and the resistance of the entire circuit drops in proportion to the length reduction of the probe. Thus, a decrease in probe voltage vs. time is recorded by a dedicated measuring device.

In this research, a DataTrap II Data/VOD recorder manufactured by MREL (Kingston, ON, Canada) was used. This device allows independent measurements of detonation velocity to be taken using eight channels, allowing the simultaneous measurement of VOD in eight blastholes. The maximum recording rate in this system is 10 MHz per channel. The uncertainty of the measurements declared by the manufacturer is  $\pm 2\%$ .

During underground trials, six-meter sections of the VOD ProbeCables were attached by electrical tape to the booster with a detonator and placed at the end of the loading hose. Blastholes were then charged according to the standard procedure, i.e., the loading hose was inserted to the bottom of the blasthole and the desired mass of the explosive was loaded. After that, the VOD probes from each tested face were connected to the communication (coaxial) cable and plugged to the recorder, which was located between the fired faces (Figure 5). The VOD probes were put into two cut holes in each of the four tested faces, which were fired with the first delay (same).

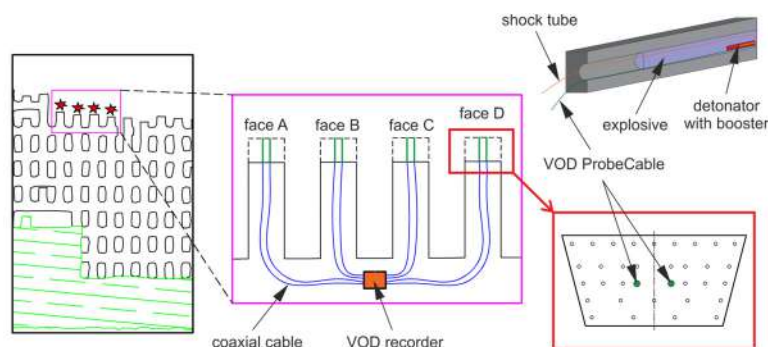

**Figure 5.** Scheme of the VOD measurements in blastholes with construction of the explosive charge.

The data analysis was performed with Data Acquisition Suite software, which converts the recorded data into a graph as a function of distance versus time. The software automatically calculates and displays the VOD of an explosive at any selected location in the graph.

### 2.7. Determination of Rock Fragmentation

Determination of the rock fragmentation was based on the image analysis method, which is one of the most common methods utilized to measure rock fragment size distribution in mines. It was carried out using a 2D photogrammetry method based on analysis of digital images of the muckpile using WipFrag software. The software applies an algorithm to detect edges, which are used to render a polygon around the particles, in order to determine the size–distribution [26,27]. To avoid issues caused by the spatial distribution of rock fragments in the muckpiles, each one was imaged multiple times during the hauling process (Table 2).

**Table 2.** Summary of images used for fragmentation analysis.

Trial Round	Face No.	Explosive Type	Number of Images
#1 (single mixer)	1	E8L	11
	2		12
	3	BK-2	10
	4		12
#2 (double mixer)	1	E8L	15
	2		14
	3	BK-2	16
	4		14

The photogrammetry method includes the following steps: (1) acquisition of multiple images representing each muckpile—pictures should be taken during hauling to depict different cross-sections of the muckpile, (2) image processing and analysis using a dedicated application—fragmentation analysis, and (3) determination of the size–distribution curve.

Since underground conditions are very difficult (no natural light, dust, humidity), one of the challenges is to ensure good quality of the photographs and reliable input data for analysis. Hence, pictures were taken by a camera with a low aperture and an additional light source in the form of a high-power LED flashlight. It should, however, be noted that this fragmentation assessment method has certain limitations caused by the image resolution and delineation algorithm. Therefore, photos were delineated automatically and corrected manually by adding or removing particle boundaries. At this stage, some fine areas were also indicated if needed. The images were scaled using an object with known dimensions; in this case, a bright foam ball, as presented in Figure 6.

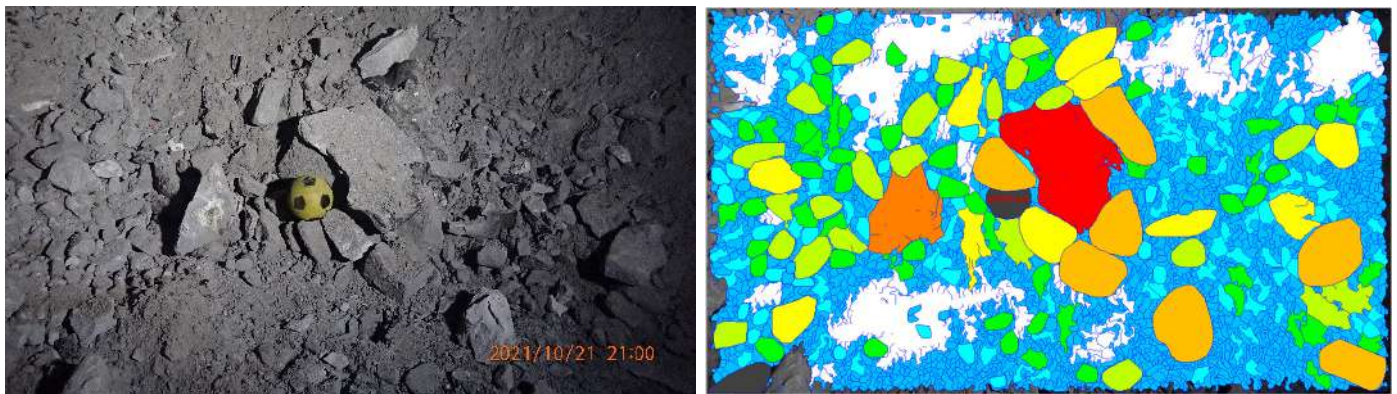

**Figure 6.** Sample photo of muckpile cross-section with a scaling ball (**left**) and part of the delineation process (**right**).

Any systems using photogrammetry methods can be characterized by a limiting size called fines cut-off (FCO), which means that below this value, the delineation is not reliable. Consequently, for fines regions (below FCO), an error between the real size of particles and those determined by analysis reaches the maximum value. Calculations of size–distribution below FCO can be performed using calibrated distribution models, such as Rosin-Rammler or Swebrec [28]. It should be noted that the calibration of distribution models requires the provision of sieving analysis data, which is very problematic or even impossible in normal underground operations. Thus, the model parameters were calculated statistically with the input of raw data obtained from image analysis. Statistical analysis was conducted using Statistica software. Calculation of model parameters was performed using the non-linear estimation method (user regression, least squares method). As the estimation function, the Swebrec equation was applied, which seems to be much better suited for blasting fragmentation and determination of fines regions [29,30].

The Swebrec model can be expressed by the following equation:

$$f(x) = \frac{1}{1 + [\ln(x_{max}/x)/\ln(x_{max}/x_{50})]^b} \quad (1)$$

where:  $f(x)$ —cumulative percent passing [%],  $x_{max}$ —size of the largest particle [mm],  $x$ —particle size [mm],  $x_{50}$ —particle size at 50% passing [mm],  $b$ —curve undulation.

The size of the largest particle was estimated in WipFrag software. Other parameters, such as  $x_{50}$  and  $b$ , were calculated in Statistica. In addition, it must be noted that, even in calibrated models, the error level below FCO can be significant (maximum value reaches 25–30% of FCO). Nevertheless, even non-calibrated models can provide valuable information on the fines distribution.

The rock fragmentation analysis consisted of firing explosives in 8 faces divided into 2 trials differing in mixer type, i.e., 4 faces per trial (2 charged with E8L and 2 with BK-2). Hence, all images in each trial concerned with a given type of explosive were analyzed together as one database. This was the basis for the determination of histograms and fragmentation curves.

### 2.8. Determination of Brisance via the Hess Method

Cylindrical lead rods of 99.97% purity were used for the determination of brisance, from which the cylinders with a diameter of  $40 \pm 0.2$  mm and height of  $60 \pm 0.15$  mm were made. The face surfaces were machined to 10 grade. They were placed vertically on the floor of excavation. Then, on the top of this cylinder, a cylindrical 1.7035 steel disc with a diameter of  $41 \pm 0.2$  mm and height of  $10 \pm 0.2$  mm was placed. Surfaces of steel discs were machined to 2.5 grade and hardened to 150–200 HB. A 50 g explosive sample loaded into a 3D printed plastic (PET-G) testing cup with an inner diameter of 40 mm and



height of 65 mm was placed on this plate and initiated, according to the scheme in Figure 7. As a result of firing, the lead cylinder was axially compressed. The change in the cylinder height was used as a measure of brisance. Samples were initiated using a standard 0.65 g PETN detonator. Since no reference material was tested underground due to the relatively high temperature, the results were compared with each other.

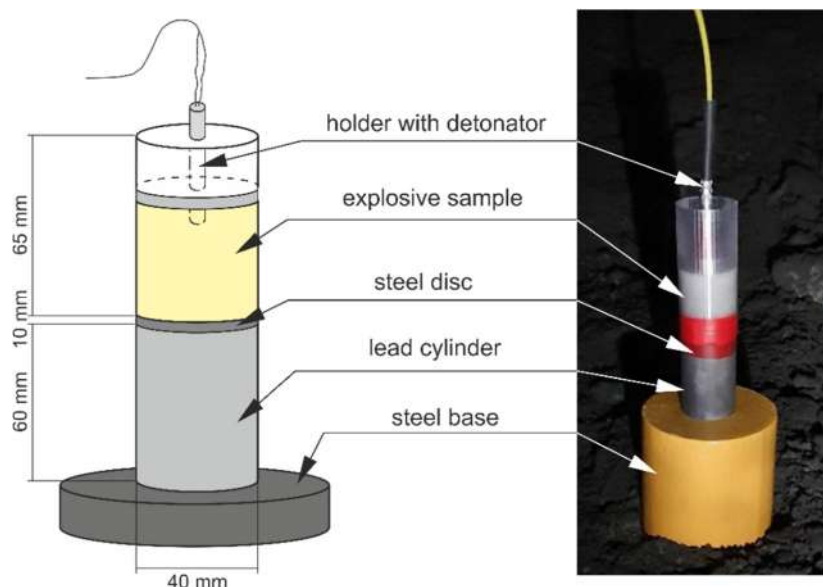
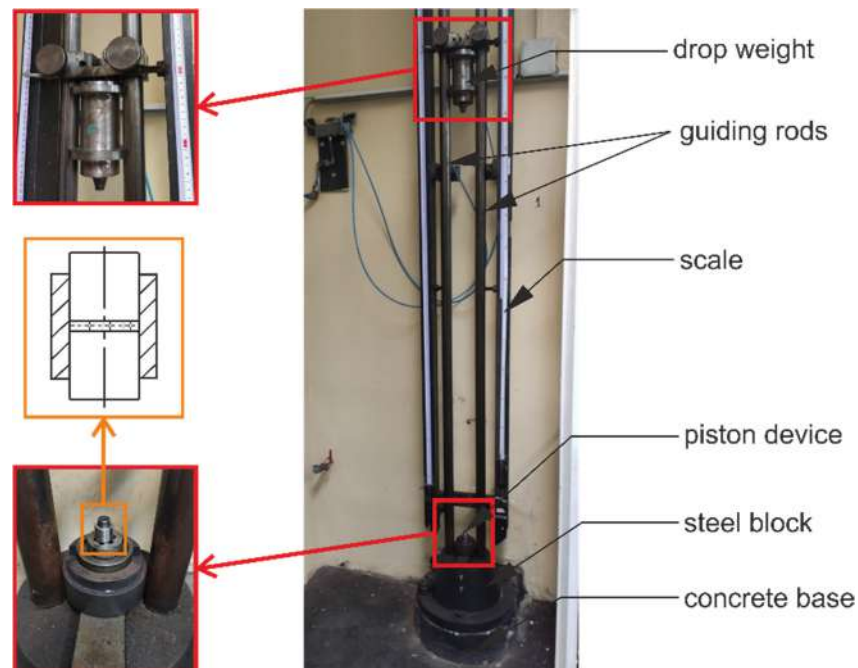

**Figure 7.** Scheme (left) and view of the sample (right) for determining brisance via the Hess method.

### 2.9. Determination of Impact and Friction Sensitivity

Determination of the sensitivity of explosives to mechanical stimuli covered the impact and friction sensitivity tests. As accepted, due to dynamic stimuli, stress and strain may appear in the explosive, which results in local heating. Those areas of local heating are the most likely causes of the explosive's initiation [31]. Both tests were conducted under laboratory conditions prior to large-scale underground trials.

The principle of the impact sensitivity test is that the sample of the tested explosive is subjected to the action of a drop weight. As a result, the mass of the drop weight and the drop height at which the initiation may occur is determined. For the impact sensitivity determination, the Kast fall hammer was used (Figure 8). In this test, a 40 mm<sup>3</sup> sample of the explosive was placed using a spatula into the open piston device, which is comprised of two steel rollers and a hollow cylinder. Then, the second roller was carefully placed onto the piston to not damage the structure of chemical sensitization and pushed up to the sample. The drop weight was then positioned at the desired height using a locking device. In this test, drop weights with a mass of 5 kg and 10 kg were used. The height varied from 20 cm to 50 cm, which represents the impact energy from 10 J to 50 J (5 J interval from 10 J to 40 J and also 50 J). Six trials were conducted for each energy and each type of explosive, which gives 2 × 48 samples. The results of the test are reported as initiation (sound, light effect, smoke) or non-initiation, in accordance with the EN 13631-4:2002 standard [32].



**Figure 8.** Scheme of the Kast fall hammer test.

For the friction sensitivity determination in turn, the Peters friction apparatus was used (Figure 9), in which friction is created electromechanically between the porcelain cylinder and the plate with the explosive sample. In this test, similar to the impact sensitivity test, a  $10 \text{ mm}^3$  sample of explosive was placed on a flat porcelain plate attached to the sliding carriage of the device. The porcelain cylinder clamped on the carriage was then lowered using the weight mounted on the loading arm. The movement of the plate with the sample was provided by a motor (stroke length 10 mm). In this test, six trials were conducted for each loading, representing the normal force starting from 360 N (load of 10.8 kg lowered at a distance of 360 mm). If detonation was observed at least once in six trials, the next six samples were tested using smaller loading at intervals specified in the EN 13631-3:2004 standard [33]. As before, the tests were conducted for each type of explosive.

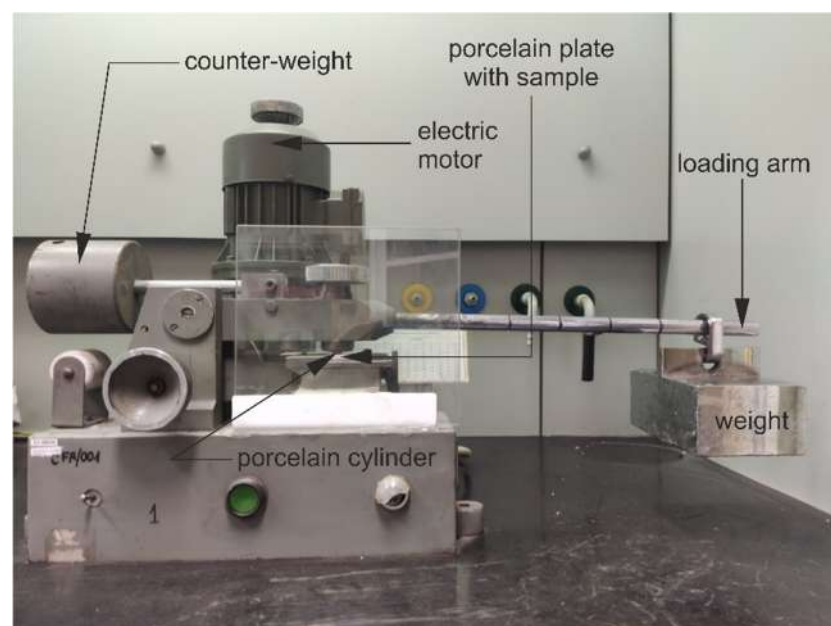

**Figure 9.** Peters friction apparatus.

### 3. Results

#### 3.1. Impact and Friction Sensitivity

The tests of impact and friction sensitivity were carried out under laboratory conditions to verify the sensitivity level of explosives to mechanical stimuli, before underground trials could be conducted. A criterion was set that the proposed explosive formulation cannot be more sensitive to impact and friction than the commercial E8L explosive.

Among 48 samples tested in the energy from 10 J to 50 J, no sample showed initiation (no sound, no light effect, no smoke) by impact. The same applies to the E8L and BK-2 formulations, which means that the impact sensitivity value of both explosives exceeded 50 J.

No detonation was observed during the friction sensitivity tests of the two explosive formulations either. None of the 12 tested samples were initiated under the loading of 10.8 kg lowered at a distance of 360 mm, indicating that the friction sensitivity value of both the E8L and BK-2 explosives exceeded 360 N.

#### 3.2. Density

The explosive samples were sensitized chemically and, due to the reaction of ammonium nitrate and sodium nitrite, a gradual decrease in sample density over time was observed. This directly affects the detonation parameters and is the key issue for mine operators to maintain high effectiveness of mining. Thus, such emulsions are desired, achieving the final density and stabilizing within a relatively short and practically justified time. This time depends on the type of mine and adopted technology. The density measurements were conducted for each trial and each type of explosive was tested based on three samples. The results are presented in Figure 10 as the average values from three samples and deviation between the maximal and minimal.

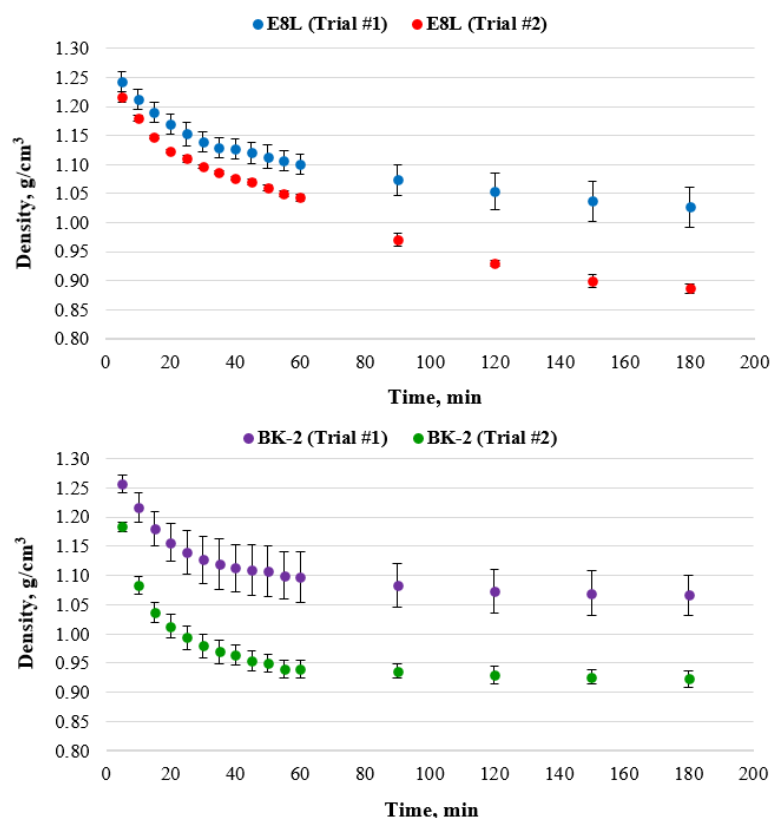

Figure 10. Graphs of changes in the density of explosives in time: E8L (top) and BK-2 (bottom).

The analysis results indicate that the blending of components using a double static mixer (#2) is much more precise than blending with a single mixer (#1). This is shown by different density values of specific samples in trial #1. In turn, the differences between densities measured in trial #2 are much closer to each other. Smaller dispersion is also observed. This indicates that thorough blending is critical for maintaining higher detonation parameters, since the sensitizer is more evenly distributed throughout the entire mass of the matrix—greater reaction surface, and thus, greater gas volume and lower density. Thus, a double static mixer is highly recommended for further blasting operations.

The novel BK-2 formulation initially showed a much more rapid density decrease than the E8L formulation. However, the density of the BK-2 formulation stabilized after approximately 30 min, unlike E8L, whose density continued decreasing noticeably, even after 180 min. In fact, all the densities measured in trial #2 reached a similar final density value; nevertheless, the decrease observed between 30 min and 180 min for BK-2 was approximately  $0.06 \text{ g/cm}^3$ , and as much as  $0.21 \text{ g/cm}^3$  for E8L.

### 3.3. Brisance

Detonation performance is fundamental in the evaluation of high explosive power and describes the energetic capacity of explosives, and therefore, their power, strength, or energy. The results are presented without units using other parameters, such as degree of compression of the metal cylinder in the case of the brisance test. The results of Hess lead block compression tests for the E8L and BK-2 formulations are presented in Figure 11.

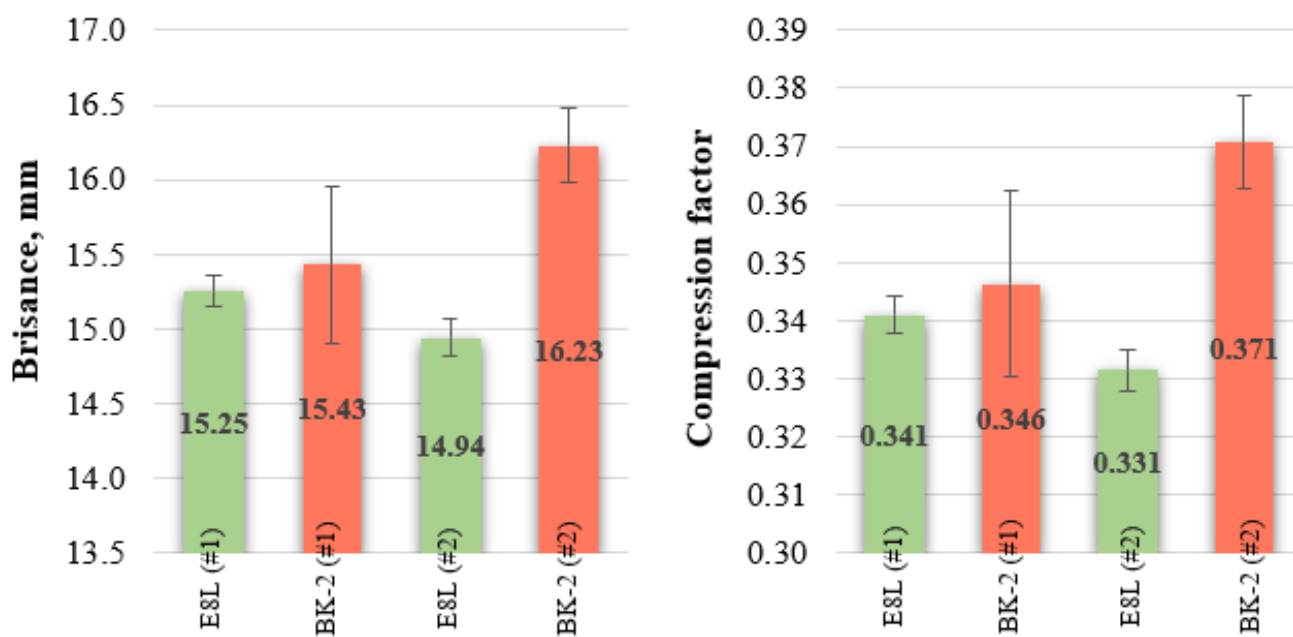

**Figure 11.** Comparison of brisance (left) and compression factors (right) determined for the tested explosives using the Hess method.

The in situ trials have proven that the brisance of the BK-2 formulation is higher than that of the standard E8L explosive. This may be mainly observed for the BK-2 samples in trial #2, in which a double mixer was used. The average compression factors for a single mixer in trial #1 for both explosives are similar and remained within the uncertainty of measurement. However, high dispersion between samples for BK-2 in trial #1 may be observed, indicating some mixing problems and that the explosive was not homogeneous. In the case of the double mixer, a 12% increase in the compression factor was observed for BK-2 in relation to E8L.

### 3.4. Detonation Velocity

In principle, the results of detonation velocity measurements of confined explosives (in blastholes) are higher than those detonated in the open air. This is mainly because the force and pressure produced by detonation is intensified on a much smaller area. However, as stated before, the VOD is affected by many parameters, especially when measuring in situ. The VOD measurements were conducted during each trial and each type of explosive was tested (four tests per explosive per trial). The time between charging the blastholes and faces firing was approximately 150 min. The results are presented in Table 3.

**Table 3.** Summary of the results of detonation velocity measurements.

Trial no.	Test No.	Velocity of Detonation [m/s]	
		E8L	BK-2
#1 (single mixer)	1	3710	3760
	2	3850	3735
	3	3880	3890
	4	3720	3895
#2 (double mixer)	1	4030	4000
	2	4060	3990
	3	4000	4060
	4	3990	4070

As proven during laboratory tests, the lower water content in the new formulation causes an increase in the velocity of detonation. However, such a conclusion has not been confirmed by underground tests. The average VOD of E8L measured in trial #1, in which a single static mixer was used, reached 3790 m/s, while the average VOD of BK-2 was 3820 m/s. The difference in the average values was 30 m/s only. However, having in mind that the uncertainty of the measurements in the system used is  $\pm 2\%$ , it may be assumed that the achieved VOD is similar for both explosive formulations.

Similar conclusions may be drawn from trial #2, in which a double mixer was applied. The average value of VOD in the case of E8L was 4020 m/s and 4030 m/s for BK-2. This means that the detonation velocity of BK-2 was not improved during the large-scale field tests in comparison with the results obtained during laboratory testing.

When analyzing the average VOD from both trials, an almost 6% increase was observed in trial #2, in which the double static mixer was used. The average detonation velocity (based on eight blastholes) increased from 3805 m/s in trial #1 to 4025 m/s in trial #2. This proved that precise blending is crucial to maintain higher detonation parameters of AN-based bulk emulsions.

### 3.5. Rock Fragmentation

Taking of the muckpile pictures started after approximately 90 min following the completion of blasting. This was required for ventilation and removing of post-blast fumes. A loader with a bucket capacity of 4 m<sup>3</sup> was used to haul the excavated rocks. The total volume of the ore from a single face was approximately 55 m<sup>3</sup>. The pictures were taken immediately after each bucket was collected. While hauling, 104 pictures in total were taken, including 45 in trial #1 and 59 in trial #2.

The analysis of the data collected during trial #1 included 23 pictures for E8L and 22 for BK-2 (sum from two faces). In the case of trial #2, the analysis of the size-distribution curves was based on 29 and 30 images, respectively, for the E8L and BK-2 explosives. The calculated fragmentation curves for both trials are shown in Table 4.

**Table 4.** Cumulative fragment size–distribution curves (blue) and histograms (red) for considered cases.

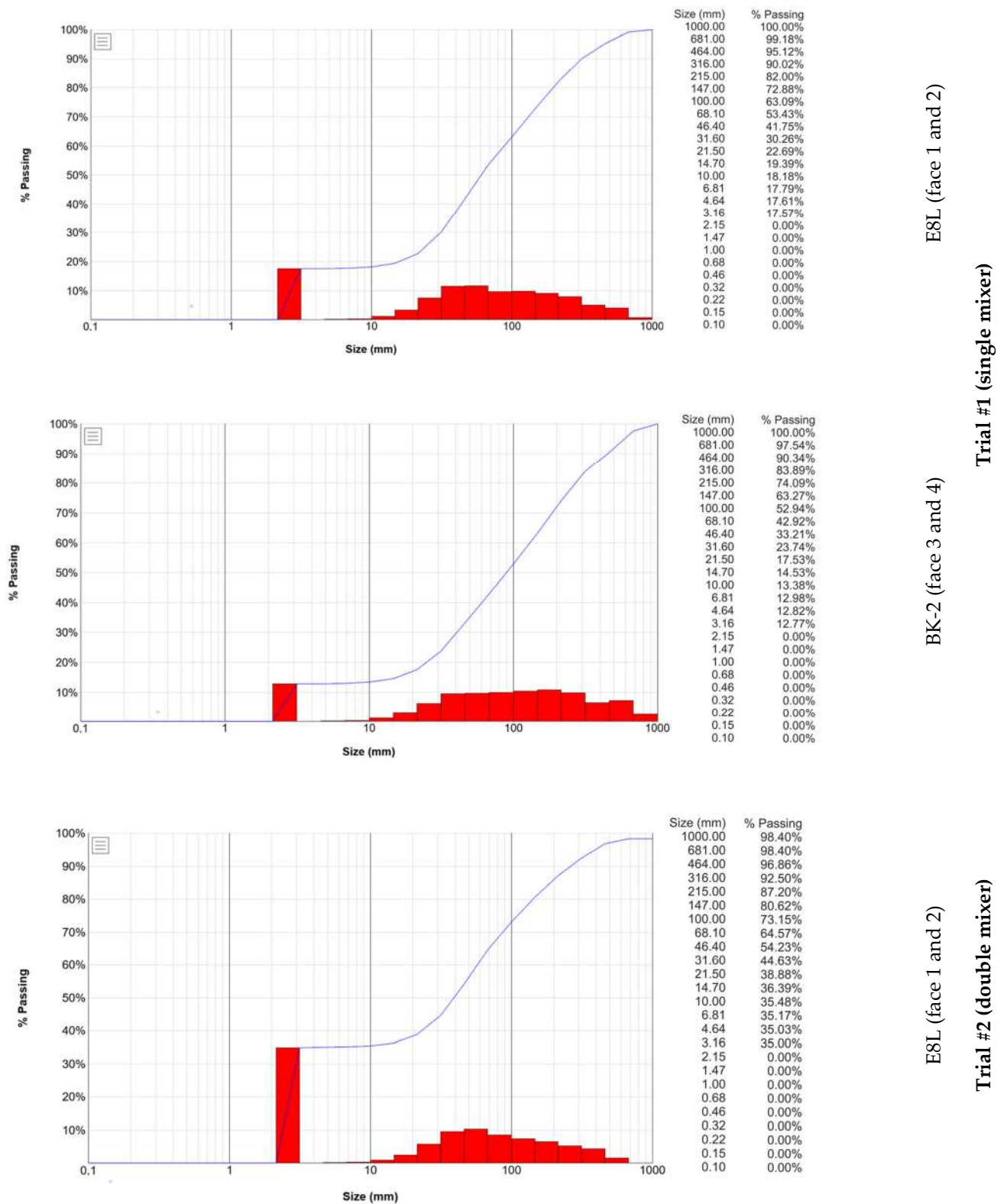

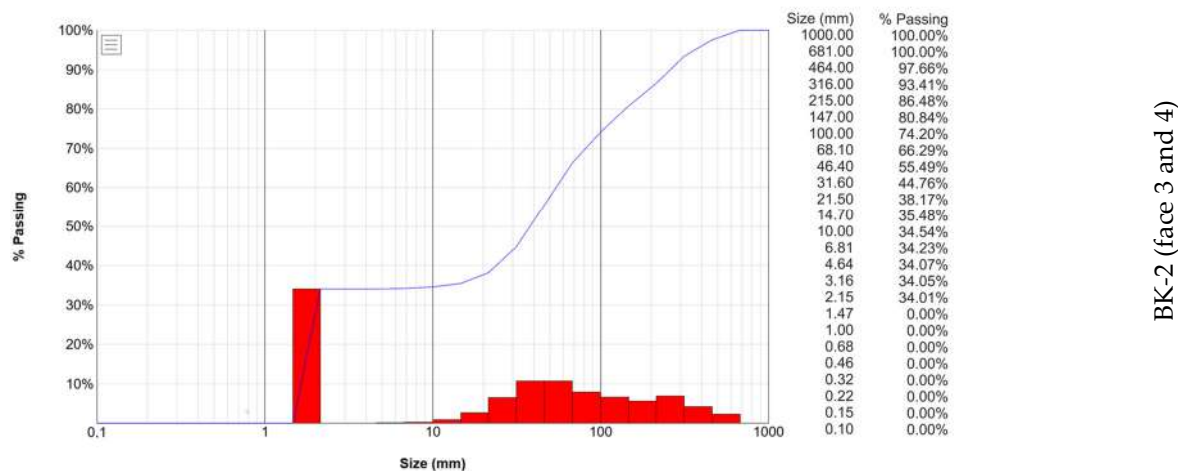

Based on Table 4, one may conclude that there is a slight difference in fragmentation between faces blasted with E8L and BK-2. The size–distribution of the outcome from E8L in trial #1 shows that more “fines” were produced in comparison with BK-2, which is a little coarser. Nevertheless, the differences do not exceed 10%. The difference in fines fraction (<3.16 mm) is approximately 5% and the content of particles bigger than 465 mm reaches 4.9% for BK-2 and 9.7% for E8L. In trial #2 in turn, there is hardly any difference in fragmentation between faces blasted using E8L and BK-2. In the range of 3.16 mm up to 1000 mm, the difference does not exceed 2% (the content of fines was approximately 35.00% for E8L and 34.05% for BK-2). Similar results were observed for coarse fractions (>465 mm), in which the content was 3.14% for E8L and 2.34% for BK-2.

For reliable determination of the fines content in both cases, the Swebrec model was applied and model data parameters were estimated using WipFrag software. Determination of parameters was based on data above FCO, which was set for 10.0 mm. Below this value, the fragmentation curve is almost flat up to 3.16 mm, which is a limit value for the applied system (lower particles cannot be recognized by the algorithm). This indicates that resolution of the system in this area was poor and the error increased rapidly. All estimated parameters for both trials are presented in Table 5. The confidence level was 95%.

**Table 5.** Estimated model parameters of the distribution model for both trials.

Explosive Type	Parameter	Value	Standard Error	Confidence Limit	
				Lower	Upper
Trial #1 (single mixer)					
E8L	$x_{max}$	684 mm	n/a	n/a	n/a
	$x_{50}$	69.50 mm	3.03 mm	62.75 mm	76.25 mm
	$b$	2.50	0.13	2.21	2.82
BK-2	$x_{max}$	866 mm	n/a	n/a	n/a
	$x_{50}$	100.14 mm	4.30 mm	90.57 mm	109.72 mm
	$b$	2.48	0.13	2.20	2.77
Trial #2 (double mixer)					
E8L	$x_{max}$	1080 mm	n/a	n/a	n/a
	$x_{50}$	35.09 mm	1.56 mm	31.66 mm	38.52 mm
	$b$	2.61	0.11	2.37	2.86
BK-2	$x_{max}$	608 mm	n/a	n/a	n/a
	$x_{50}$	35.86 mm	1.85 mm	31.73 mm	39.99 mm
	$b$	2.08	0.11	1.83	2.32

As mentioned before, the Swebrec function is much more reliable for the description of the fines region in terms of blasting. Since very good fitting of the model to the data (above FCO) was observed, cumulative fragmentation curves for both trials and both types of tested explosives using the Swebrec function were compared, as shown in Figure 12.

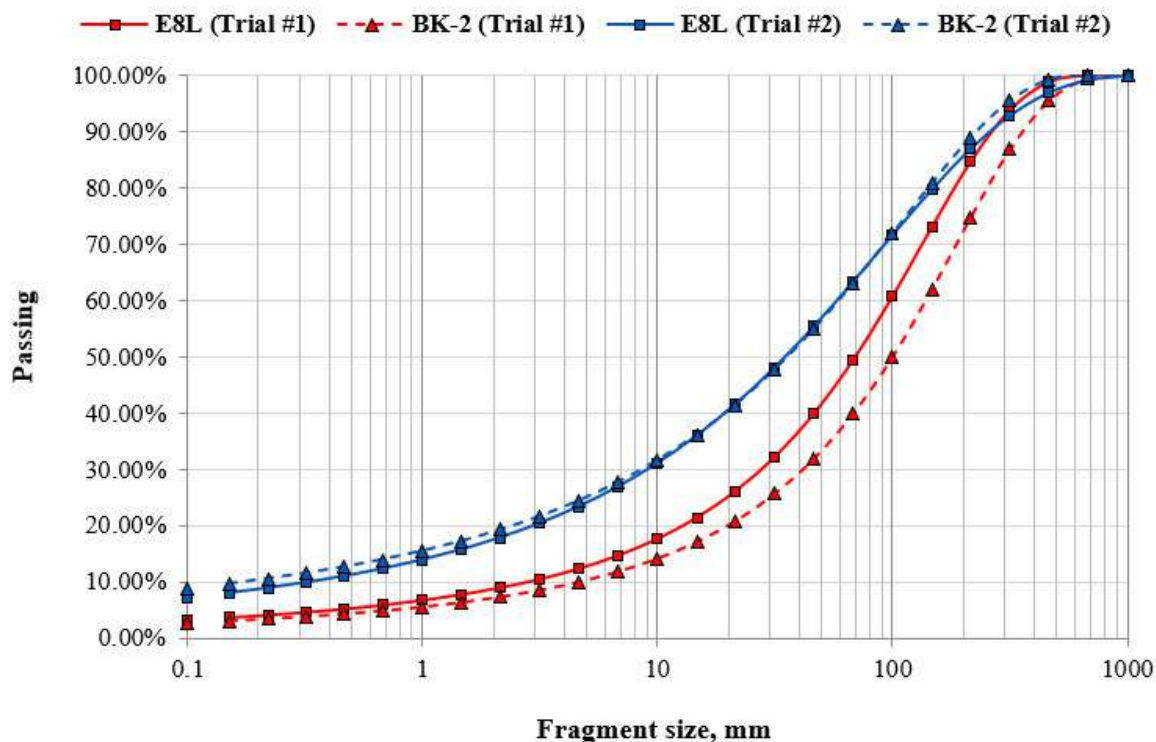

Figure 12. Comparison of Swebrec models for both trials.

From Figure 10, one may conclude that the maximum differences between the given fractions in trial #1 slightly exceed 11%. The maximum difference is 11.1% and can be observed in the range of particle size between 50 mm and 200 mm. In the fines region in turn, the differences are negligible. Finally, it can be concluded that, from a practical point of view, the changes in the fragmentation distribution obtained in trial #1 using two types of explosive are insignificant and do not have a major impact on the blast outcome in relation to fragmentation. Similar conclusions may be drawn from the results of trial #2, in which a double static mixer was used. The plotted curves showed that there was hardly any difference between both cases. It can, therefore, be concluded that the type of explosive and the mixing method did not affect the fragmentation of blasted rocks. However, it should be emphasized that there is a visible difference between the fragmentation achieved in trial #1 and trial #2, indicating a significant influence of the mixing method. Much better fragmentation was achieved for both explosives in trial #2, in which a double mixer was used.

#### 4. Discussion

The results of the research showed that parameters of the novel bulk emulsion explosive with improved energetic parameters obtained during underground trials are not, in principle, consistent with results obtained in the first phase of investigations under laboratory conditions. Differences in the energetic performance of the two explosive formulations are relatively minor. Most of the tested parameters are similar for each type of explosive and each type of component mixing (single or double static mixer). The



novel BK-2 formulation exhibits a similar sensitivity level to mechanical stimuli (impact and friction) as the standard E8L explosive.

The sensitization of BK-2 is much faster and much more stable than that of E8L. In underground conditions, where temperature usually ranges from 25 °C to 35 °C, it is capable of detonation after 5 min. Moreover, the final density is obtained after approximately 30 min. In comparison, the standard E8L explosive in such conditions is capable of detonation after at least 30 min. It usually achieves the final density after more than 12 h. In addition, the time between the loading of blastholes and firing varies depending on the location of the blasting site, which is limited by the ventilation constraints.

It should, however, be noted that sensitization cannot be too rapid, because an excessively fast reaction will cause certain difficulties from a practical point of view, such as an increase in pressures and other problems related to the mixing–charging unit. However, there were no significant problems with the loading unit for the BK-2 formulation and all the pressures and flows were normal. On the other hand, it is much better and safer, while charging, to operate with emulsion that is not capable of detonation. Thus, this time should not be too short. It should definitely be reduced in relation to the standard E8L, but within reason. More important, however, is the stability of the BK-2 formulation, which became stable after about 30 min.

In terms of the brisance determination via the Hess method, the BK-2 and E8L formulations achieved comparable values when using a single mixer. In the case of a double mixer (trial #2), an approximately 12% increase in the compression factor was observed for the BK-2 formulation in relation to E8L. In comparison, the difference in brisance obtained under laboratory conditions for BK-2 was almost 32% higher than the brisance of E8L. This shows how precise mixing influences the working capacity of novel formulations of explosives. It should also be noted that the brisance results cannot be referenced to results of high explosive samples due to safety constraints. Moreover, the impact of high temperatures of lead cylinders on results has not been defined so far. Thus, the results were compared with each other.

The measurements of detonation velocity did not prove the results obtained during laboratory tests, i.e., that lower water content in the new formulation will cause an increase in the detonation velocity. In conditions where the emulsion components were blended manually, the VOD of BK-2 was, on average, almost 19% higher than that obtained for E8L. The in situ tests have confirmed that the differences in the average values remained within the uncertainty of the measuring system in both trials, which means that the detonation velocity of novel formulations was not improved during the large-scale field tests.

In the case of blast fragmentation analysis, it may be stated that the differences in the fragment size–distribution in both trials are insignificant. The shape of plotted curves from each trial and for each type of explosive are similar. Thus, it may be concluded that for given mining and geologic conditions, the type of explosive and the method of component mixing did not affect the fragmentation of blasted rocks.

There is, however, one issue to which special attention should be paid. This is the method of component mixing using a static mixer. In this research, single (trial #1) and double (trial #2) static mixers were implemented and verified. The mixture of the matrix and sensitizer is much more homogeneous when using a double mixer than when using a single one. In fact, the mixture is not homogeneous, but far better blended using a double mixer, which was confirmed by different density values of specific samples in trial #1. Meanwhile, the differences between densities measured in trial #2 are much closer to each other. This proves that precise blending is critical for maintaining higher detonation parameters and a double static mixer is recommended for both the E8L and BK-2 formulations. In the case of BK-2, a much greater effect of precise mixing on the spread of density values may be observed. Thus, one can expect that the refinement of the mixing system for a novel formulation will result in a significant improvement in energetic parameters, which has been proven during laboratory tests where the mixing was very

precise and almost perfect. In contrast to E8L, the BK-2 formulation is based on a hybrid sensitization, i.e., that apart from the gassing reaction, the reaction of precipitating fine ammonium perchlorate crystals in the matrix occurs in parallel, which can only be achieved with very precise mixing of components.

The same conclusion can be drawn from the brisance tests, in which the highest compression factor was obtained for BK-2 when a double mixer was used. From a detonation velocity point of view, an approximately 5–6% increase in average values was observed in tests with a double static mixer. The average VOD measured for E8L increased from 3790 m/s to 4020 m/s and from 3820 m/s to 4030 m/s for BK-2. This proves that slightly higher detonation velocities may be achieved when a double static mixer is used. Finally, this finding also applies to the results of fragmentation, which was improved by more than 20% in some fragment size ranges, when the double mixer was used.

## 5. Conclusions

A comparison of the results of experiments conducted in actual use conditions and those conducted in laboratory conditions, discussed in our previous work [24], shows that the emulsion explosive densities obtained under laboratory conditions cannot be obtained using commonly used mixing–charging units, due to the method of component mixing. Despite the inadequate mixing of BK-2, its performance is comparable to that of E8L.

Consequently, developing a mixing–charging system that would allow a sufficient degree of mixing to be achieved and, therefore, allow peak performance of BK-2, is an important aspect of future work on modifying emulsion explosive formulations. Taking into account the prospective results of laboratory tests and the observations from the presented work, achieving the above goal necessitates further tests, so as to refine and redevelop the mixing method for the BK-2 formulation.

On the other hand, despite the use of a single mixer and inaccurate mixing, no misfires were observed for BK-2, and the produced explosive has similar physical parameters to those of the standard E8L emulsion explosive formulation. This indicates that the BK-2 formulation exhibits a high degree of tolerance to technical issues or errors taking place during the charging of the blastholes, potentially alleviating occurrences which would otherwise compromise the viability of a less error-tolerant emulsion explosive formulation.

It should also be highlighted that the faces were loaded using a mixing–charging unit that was designed specifically for the standard E8L emulsion explosive formulation. Nevertheless, the results achieved for the novel BK-2 formulation are very promising. From a mining point of view, the greatest advantage of this formulation is its rapid stabilization of the density over time.

In summary, a significant improvement in the sensitization rate, a shorter time required to reach the final emulsion explosive density, and an increased stability of the sensitized bulk emulsion have all been achieved. This is especially important when firing several faces loaded at different times. Although the rate, at which the final parameters of the bulk emulsion explosive are achieved can in principle be further shortened, further work needs to take into account that the sensitization process cannot be too rapid, because an excessively fast reaction will cause certain practical and technical difficulties, such as increased pressure in the blastholes, as well as possibly introducing inhomogeneity defects in the sensitized emulsion explosives.

**Author Contributions:** Conceptualization, P.M. and B.K.; methodology, P.M., B.K. and M.P.; validation, P.M., T.J. and K.J.; formal analysis, P.M., B.K., M.P. and M.S.; investigation, P.M., B.K., M.P. and M.S.; data curation, P.M., B.K., M.P. and T.J.; writing—original draft preparation, P.M., B.K., M.P., M.S. and T.J.; writing—review and editing, P.M., T.J. and K.J.; visualization, P.M., B.K., M.P., M.S. and T.J.; supervision, P.M. and T.J.; project administration, P.M. and B.K.; funding acquisition, T.J. and K.J. All authors have read and agreed to the published version of the manuscript.

**Funding:** T.J. acknowledges the Silesian University of Technology grant No. 04/040/BKM22/0215.

**Data Availability Statement:** Not applicable.

**Conflicts of Interest:** The authors declare no conflicts of interest.

## References

- Bluhm, H.F. Ammonium Nitrate Emulsion Blasting Agent and Method of Preparing Same. U.S. Patent 3447978, 3 June 1969.
- Sifferlinger, N.A.; Hartlieb, P.; Moser, P. The importance of research on alternative and hybrid rock extraction methods. *Berg. Huettenmaenn. Monatsh.* **2017**, *162*, 58–66.
- Pickering, R.G.B.; Young, C. Controlled foam injection: A new and innovative non-explosive rockbreaking technology. *J. S. Afr. Inst. Min. Metall.* **2017**, *117*, 237–243.
- Ranjith, P.G.; Zhao, J.; Ju, M.; De Silva, R.V.S.; Rathnaweera, T.D.; Bandara, A.K.M.S. Opportunities and challenges in deep mining: A brief review. *J. Eng.* **2017**, *3*, 546–551.
- Fairhurst, C. Some challenges of deep mining. *J. Eng.* **2017**, *3*, 527–537.
- Sil'vestrov, V.; Plastinin, A.; Karakhanov, S.; Zykov, V. Critical diameter and critical thickness of an emulsion explosive. *Combust. Explos. Shock Waves* **2008**, *44*, 354–359.
- Mendes, R.; Ribeiro, J.; Plaksin, I.; Campos, J.; Tavares, B. Differences between the detonation behavior of emulsion explosives sensitized with glass or with polymeric micro-balloons. *J. Phys. Conf. Ser.* **2014**, *500*, 427052030.
- Balakrishnan, V.; Pradhan, M.; Dhekne, P. Field investigation in the detonation behavior of emulsion explosive column induced with air gaps. *Min. Sci.* **2019**, *26*, 55–68.
- Lyashenko, V.; Vorob'ev, A.; Nebohin, V.; Vorob'ev, K. Improving the efficiency of blasting operations in mines with the help of emulsion explosives. *Min. Miner. Depos.* **2018**, *12*, 95–102.
- Mertuszka, P.; Szumny, M.; Fuławka, K.; Maślej, J.; Saiang, D. The effect of the blasthole diameter on the detonation velocity of bulk emulsion explosive in the conditions of selected mining panel of the Rudna mine. *Arch. Min. Sci.* **2019**, *64*, 725–737.
- Kabwe, E. Velocity of detonation measurement and fragmentation analysis to evaluate blasting efficacy. *J. Rock Mech. Geotech. Eng.* **2018**, *10*, 523–533.
- Cooper, P.W. Acceleration, formation and flight of fragments. In *Explosives Engineering*, 1st ed.; Cooper, P.W., Ed.; Wiley-VCH: New York, NY, USA, 1996; pp. 385–394.
- Mertuszka, P.; Fuławka, K.; Cenian, B.; Kramarczyk, B. Impact of initiation method of bulk emulsion explosive on the velocity of detonation based on Emulinit 8L. *Przegląd Górniczy* **2017**, *5*, 8–16. (In Polish).
- Gupta, R.N.; Adhikari, G.R.; Venkatesh, H.S.; Theresraj, A.I.; Verma, H.K. Evaluation of explosives performance through in-the-hole detonation velocity measurement. In *Research Work of National Institute of Rock Mechanics*; National Institute of Rock Mechanics: Kolar Gold Fields, India, 2001.
- Agrawal, H.; Mishra, A.K. A study on influence of density and viscosity of emulsion explosive on its detonation velocity. *Model. Meas. Control* **2017**, *78*, 316–336.
- Mertuszka, P.; Fuławka, K.; Pytlik, M.; Wincenciak, J.; Wawryszewicz, A. The influence of time on the density and detonation velocity of bulk emulsion explosives—a case study from Polish copper mines. *Cent. Eur. J. Energ. Mater.* **2019**, *16*, 245–258.
- Pradhan, M. Sleep time: Its consequences on performance of bulk emulsion explosive. *J. Sci. Ind. Res.* **2010**, *69*, 125–128.
- Mertuszka, P.; Kramarczyk, B. The impact of time on the detonation capacity of bulk emulsion explosives based on Emulinit 8L. *Propellants Explos. Pyrotech.* **2018**, *43*, 799–804.
- Pradhan, M. Effect of charge temperature on the detonation velocity of bulk emulsion explosives. *J. Inst. Eng.* **2009**, *90*, 3–7.
- Mertuszka, P.; Fuławka, K.; Pytlik, M.; Szastok, M. The influence of temperature on the detonation velocity of selected emulsion explosives. *J. Energ. Mater.* **2020**, *38*, 336–347.
- Baranowski, P.; Mazurkiewicz, Ł.; Małachowski, J.; Pytlik, M. Experimental testing and numerical simulations of blast-induced fracture of dolomite rock. *Meccanica* **2020**, *55*, 2337–2352.
- Baranowski, P.; Kuciewicz, M.; Pytlik, M.; Małachowski, J. Shock-induced fracture of dolomite rock in small-scale blast tests. *J. Rock Mech. Geotech. Eng.* **2022**, in press.
- Türker, L. Velocity of detonation—a mathematical model. *Acta Chim. Slov.* **2010**, *57*, 288–296.
- Kramarczyk, B.; Pytlik, M.; Mertuszka, P.; Jaszcz, K.; Jarosz, T. Novel sensitizing agent formulation for bulk emulsion explosives with improved energetic parameters. *Materials* **2022**, *15*, 900.
- Kramarczyk, B.; Mertuszka, P. Study of the influence of sensitizer content on the density of a bulk emulsion explosive used in underground operations. *Cent. Eur. J. Energ. Mater.* **2021**, *18*, 429–447.

26. Wimmer, M.; Ouchterlony, F. 2D image analysis using WipFrag software compared with actual sieving data of Kiruna magnetite loaded from a draw point. In *Swebrec Report*; Luleå University of Technology, Swedish Blasting Research Centre: Luleå, Sweden, 2009.
27. Nanda, S.; Pal, B. Analysis of blast fragmentation using WipFrag. *Int. J. Innov. Sci. Res. Technol.* **2020**, *5*, 1561–1566.
28. Sanchidrián, J.A.; Segarra, P.; Ouchterlony, F.; López, L.M. On the accuracy of fragment size measurement by image analysis in combination with some distribution functions. *Rock Mech. Rock Eng.* **2009**, *42*, 95–116.
29. Ouchterlony, F. The Swebrec© function: Linking fragmentation by blasting and crushing. *Min. Technol. Trans. Inst. Min. Metall.* **2005**, *114*, 29–44.
30. Coello-Velázquez, A.L.; Quijano Arteaga, V.; Menéndez-Aguado, J.M.; Pole, F.M.; Llorente, L. Use of the Swebrec function to model particle size distribution in an industrial-scale Ni-Co ore grinding circuit. *Metals* **2019**, *9*, 882.
31. Sućeska, M. *Test Methods for Explosives*. Springer Science + Business Media: New York, NY, USA, 1995.
32. EN 13631-4:2002; Explosives for Civil Uses. High Explosives–Part 4: Determination of Impact Sensitiveness to Impact of Explosives. European Standard: Pilsen, Czech Republic, 2002.
33. EN 13631-3:2004; Explosives for Civil uses. High Explosives–Part 3: Determination of Impact Sensitiveness to Friction of Explosives. European Standard: Pilsen, Czech Republic, 2004.