



**Silesian
University
of Technology**

DEPARTMENT OF FUNDAMENTALS
OF MACHINERY DESIGN

Doctoral Thesis

Development of a Power and Communication Bus Using HIL and
Computational Intelligence Techniques

Author: M.Sc. Eng. Marek Sznura

Dissertation advisor: Ph.D. D.Sc. Eng. Piotr Przystałka, Associate Professor

Industry supervisor: Ph.D. Eng. Wojciech Sebzda

Gliwice, 2021

This thesis is the result of several years of intensive work and observation of the needs of the automotive industry.

Neither the object of research nor the idea of solving this technical problem would have come into being without the help and support of many people, especially the authorities and employees of the university and the Faculty of Mechanical Engineering.

I would like to thank the Dräxlmaier Company for support. Above all, I would like to thank my supervisor Gerd Vogler for his support and motivation to complete the conceptual and technical work.

I would also like to thank the industry supervisor Ph.D. Eng. Wojciech Sebzda, and the whole team at Dräxlmaier Gliwice for their support and knowledge sharing, which significantly improved the quality of the described solution.

Special thanks I give to my PhD thesis supervisor Ph.D. D.Sc. Eng. Piotr Przystałka, Associate Professor, without whom this work would never have achieved such a significant result. Thank you for the continuous improvement of research results and achieved results.

I would also like to thank my family, especially my wife, for her support, patience and understanding, especially in the period of writing my doctoral thesis.

Marek Sznura

Gliwice, December 2021

Contents

Glossary of Acronyms and Terms	1
1 Introduction	4
1.1 Motivation and Research Problem	5
1.2 Purpose of the Thesis	8
1.3 Scope of the Thesis	8
1.4 Acknowledgments	12
2 Modern Vehicles Engineering	13
2.1 Conventional Vehicles	14
2.2 Battery Electric Vehicles	15
2.3 Hybrid Vehicles	16
2.4 Hydrogen Vehicles	16
2.5 View on Carbon Dioxide Emission	17
2.6 Vehicle Architecture Comparison	18
2.7 Reduction of Carbon Dioxide Emission	20
2.7.1 Reduction by Clean Energy	20
2.7.2 Reduction by Optimizing Traffic	21
2.7.3 Reduction by Optimizing the Vehicle Construction	22
2.7.4 Reduction by Proper Architecture	22
2.7.5 Bill of Materials Analysis	23
2.8 Conclusion	24

3	Potential for Optimization	25
3.1	Automotive Harnesses	25
3.2	Harness Analysis	26
3.3	Proposal of Optimization	27
3.3.1	Assumption of Desired Solution	31
3.3.2	Proposal of New Solution	32
3.4	Analysis of the New Concept	36
3.5	DLN in Future Use	37
3.6	Automatization of Production	37
3.7	Analysis of Automatization of the New Concept	40
4	DLN development	42
4.1	Auto-addressing Methods	42
4.1.1	Method Selection	42
4.1.2	Auto-addressing Configuration	43
4.2	Test Description and Research Stand	43
4.3	HIL-based Optimization	51
4.4	Selected Optimization Techniques	56
4.4.1	Latin Hypercube Sampling	57
4.4.2	Single or Multi-objective Genetic Algorithm	59
4.4.3	Particle Swarm Optimization	64
5	Verification and Validation	67
5.1	Optimization Results Obtained Using LHS	67
5.2	Optimization Results Obtained Using MOGA	68
5.2.1	Quantitative Analysis of MOGA Results	68
5.2.2	Qualitative Analysis of MOGA Results	69
5.2.3	Best Solutions from MOGA	70

5.2.4	Analysis of all MOGA Results	72
5.2.5	Summary of MOGA Optimization	73
5.3	Optimization Results Obtained Using PSO	73
5.3.1	Quantitative Analysis of PSO Results	74
5.3.2	Qualitative Analysis of PSO Results	74
5.3.3	Analysis of all PSO Results	77
5.3.4	Summary of PSO	78
5.4	Summary of all Optimization Results	78
5.5	Industrialization Potential	79
6	Implementation to the Industry	85
7	Conclusions	86
	Summary	
	Streszczenie	

List of Figures

2.1	Different Types of Power Source in Vehicles	13
2.2	Types of Vehicle Architecture	14
2.3	CO ₂ Emission in Different Architectures and Fuel Sources	19
2.4	Global Greenhouse Gas Emission by Sector	21
3.1	Mercedes S-class W222 Door Harness	26
3.2	Oscillograms from Transmission Line	34
3.3	Proof of Concept of DLN Solution	34
3.4	DLN Signal Waveform	35
3.5	DLN Signal at 2Mbps	35
3.6	The Wire Harness Paced Assembly Table	38
3.7	Point Soldering Sequence	39
4.1	Auto-addressing Signal: a) Standard Signal b) Zoom to Auto-addressing Pulse c) Zoom for Preparation Line to the First Pulse d) Zoom to Pulse Generation and Sampling the Answer on the Line	45
4.2	Pulse Generator Schematic	47
4.3	Schematic of LC Terminators	47
4.4	A Data Flow Between Research Stand Modules	49
4.5	Research Stand Consisting of Master and Clients in HIL Configuration	50
4.6	One of the Characteristic Trends of Addresses Value	53
4.7	General Scheme of the Proposed Method	55
4.8	Genetic Algorithm Workflow [18]	60

5.1	The Visualisation of Optimization Results Obtained Using LHS	68
5.2	The Visualisation of Number of Correct Solutions Corresponding to Values of Selected Behavioral Parameters of MOGA	69
5.3	The Visualisation of Optimal Solutions for Different Number of Generations and Population Sizes	70
5.4	The Visualisation of Optimal Solutions for Different Values of the Crossover Fraction	71
5.5	The Visualisation of Optimal Solutions for Different Values of the Crossover Heuristic Parameter	71
5.6	The Bubble Visualization of Quantitative Results of Different PSO Configu- rations	75
5.7	Results of PSO Obtained for the Swarm Size = 50	76
5.8	Results of PSO Obtained for the Swarm Size = 100	76
5.9	Results of PSO Obtained for the Swarm Size = 200	76
5.10	Overall Optimization Results Obtained by all the Algorithms (black Ball — LHS, red Fronts and Diamonds — MOGA, blue x — PSO	78
5.11	The Comparison of Correct Addresses after 5000 Attempts	81
5.12	Simulation of Filtering Addresses of two Nodes	81
5.13	Four Wrong Measurements in a Row	82
5.14	Four Wrong Measurements in Random Places	82
5.15	Results of Kalman Filtering for 14 Nodes	84

List of Tables

3.1	Cables Thickness in Door Panel	27
3.2	Optimization Scenarios Comparison	36
4.1	A List of Decision Variables with Descriptions	46
4.2	The Components of LC Terminator	47
4.3	The 1st Auto-addressing Strategy	48
4.4	The 3rd Auto-addressing Strategy	48
5.1	The Sum of Correct Results Using Proposed Values of MOGA Parameters (Colour Code: green → the best; Light green → better than 70% of best; orange → better than 40% of best; red → worse than 40% of best)	69
5.2	Colour Codes for Figures	70
5.3	The Comparison of Selected Optimal Values of Decision Variables for MOGA	72
5.4	Best Results of MOGA	72
5.5	PSO Parameters and Colour/Shape Codes for Figures	74
5.6	The Sum of Correct Results Using Proposed Values of PSO Parameters (Colour Code: green → the best; Light green → better than 70% of best; orange → better than 40% of best; red → Worse than 40% of best)	74
5.7	The Comparison of Optimal Values of Decision Variables	80
5.8	Optimization Results Comparison Taking into Consideration Industrializa- tion Potential	80

Abbreviations Glossary

AC - Alternating Current

A/S - Actuator or Sensor

AD - Autonomous Driving

AP - Access Point

p_h - Hardware Parameters

p_s - Software Parameters

C - Global Criteria

CAD - Computer Aided Design

CAN - Controller Area Network

CM - Selected Capacitor on Master

Cfra - Crossover Fraction (GA parameter)

CHP - Crossover Heuristic Parameter (GA parameter)

CV - Conventional Vehicle

DC - Direct Current

DLN - Device Lightweight Network

ECU - Electronic Control Units

EGR - Exhaust Gas Recirculation

EMI - Electromagnetic Interference

EV - Electric Vehicle

FCV - Fuel Cell Vehicle

GA - Genetic Algorithm

GI - Inductor in Pulse Generator

GMSL - Giga-bit Multimedia Serial Link

GT - Time to Charge Pulse Generator

HIL - Hardware-in-the-loop

HV - Hybrid Vehicle

IC - Internal Combustion Engine

IM - Selected Inductor on Master

IOT - Internet Of Things

KSK - Kundenspezifischer Kabelbaum

LHS - Latin Hypercube Sample

LIN - Local Interface Network

MDA - Minimal Difference Between Addresses

MOGA - Multi Objective Genetic Algorithm

MQTT - Message Queuing Telemetry Transport

NMP - N-methyl Pyrrolidone

OA - Optimization Algorithm

OEM - Original Equipment Manufacturer

PCB - Printed Circuit Board

PS - Power Supply

PSO - Particle Swarm Optimization

PWM - Pulse With Modulation

Rpi - Raspberry Pi

SOGA - Single Objective Genetic Algorithm

STP - Shielded Twisted Pair

QM - Quality Management in ISO26262

THT - Through-hole Technology

UML - Unified Modeling Language

Ω - Optimization Boundaries of \mathbf{p}_h and \mathbf{p}_s

1. Introduction

The revolutionary transformation of the transportation industry started with steam locomotives developed in the early 19th century [108]. Those were heavy, fully mechanical machines, where speed was mechanically regulated [30]. The first internal combustion car designed by Benz in 1885 [31] was a lightweight machine compared to trains and their steam engines. In 1908, the first traffic rules were initiated at The Paris Convention, which caused the first impulse to equip cars with elemental safety measures, making the exploitation less hazardous, thus, in effect, road traffic started to be better organized [134] and cars became safer. In 1915 Ford Motor Company implemented electric horns and headlamp, than followed by turn signals, electric wipers, and other equipment [45]. In the seventies of the 20th century, first active safety devices, like airbags [104] and radars [55] were introduced. It was then when automotive suppliers recognized the excessive growth of wiring harness. In the 1980s, Bosch proposed the first data interface called controller area network (CAN) for reducing the number of wire harnesses' [10, 81]. Nowadays, cars are being excessively equipped with electronic systems, electronic control units (ECU) and interfaces [99].

The current automotive market is focused on two major trends, electric automobile and autonomous driving development (AD). According to Statista, from 2015 the number of patents has been grown exponentially, achieving 3608 patents in 2019 [133]. The leader in this area is Toyota Motors, with its 626 patents. AD requires even more connections to simple sensors, radars and cameras. Numerous sensors and actuators necessitate a whole spectrum of interfaces, with multiple baud rate and power consumption. Interface gigabit multimedia serial link (GMSL) [87] is currently used for cameras, where mainly the one-way communication is necessary. GMSL allows using only coaxial cable to transmits power (using power over coaxial) and gigabits of data per second.

Automobiles are widely considered a subject of mechanical engineering, which is why a car service person is customarily referred to as a mechanic. However, today this perception is still valid for suspension maintenance and only in simple cars. The mechanical heart of a conventional vehicle, internal combustion engine (IC), started in 1954 to become a mechatronic system, due to the first use of fuel injectors in automotive [69].

Nowadays, IC is a full mechatronic system with multiple supportive elements, increasing driver's experience like mechanical and electric turbocharger, compressor, injectors, etc. or elements which reduce environmental impact, exhaust gas recirculation (EGR), oxygen sensor (or lambda sensor), etc.

In recent years, car manufacturers have improved IC mainly by adding or changing certain accessories, like turbocharger or new fuel injectors. The design of a harness is divided into two areas: electrical connections (net list) and mechanical modelling [79]. Each single cable has to be designed and the space for it has to be planned. The mechanical protection has to be analysed and designed, cables can be taped with different materials, or a cable tray has to be designed. Automotive manufacturers do not publicize time effort of every single engineer group. However, it is highly likely that in harness development, higher percentage of worked hours is done by mechanical engineering than in internal combustion engine development.

The Dräxlmaier engineers have been recognizing the effort of the developing process and production materials which are necessary. It has been decided that this problem is worth investigating and trying to optimize some of the above issues. The author has a unique opportunity to have a holistic view on all aspects of sharing information and power distribution in the car to analyse and optimize the harness by taking into consideration the mechanical engineering, environmental impact, cost reduction and reliability improvement.

1.1 Motivation and Research Problem

As it can be read in [97] and [93], harness can weigh from 15 kg in small combustion engine car, about 20 kg in small electric vehicle (EV), to 91 kg in luxury vehicles [113]. The mass of the vehicle has a significant impact on energy consumption [70], but nowadays, EV manufacturers are partly solving this problem by using recuperation [71]. According to the results presented in [97], wiring harness can cost up to 1000 USD. The harness simplicity can lead to significant reduction of weight, cost and risk of failure during operation of the vehicle [32].

Kosai et al. conducted analyses [77] based on outcomes released by Japan Automobiles Research Institute [58] and they concluded that automotive harness required 187.9 MJ/kg of energy to its production, from 4 GJ to 17 GJ for a single car, for wire harness with masses of 20 kg to 91 kg respectively. Depending on a country where the harness

is produced, CO₂ emission per 1 MWh varies. Countries with highly-developed electric grids, like Switzerland, relying on nuclear power plants and renewable sources, can produce only 3 kg CO₂ or 12 kg CO₂ in Sweden, up to 767 kg CO₂ in Poland or 774 kg CO₂ in India for each MWh [94]. For further investigations a fixed value would have to be selected, due to the factory location in low labour cost countries, the author decided to calculate the average countries like China and India, which gave the value of 756.5 kg CO₂ per MWh. Harness manufacturing is flawed by huge carbon footprint, 0.592 to 3.55 Mg of CO₂ emission per one car (39.5 kg CO₂ per 1 kg harness). For comparison, conventional vehicle (CV) car body weight is approximately to about 424 kg [77] which requires 3.3 Mg of emitted CO₂ [77] (only 7.88 kg CO₂ per 1 kg hot-rolled steel).

Considering the examples discussed above and state-of-the-art harness systems reports [93], reducing the CO₂ emissions by production and exploitation of vehicle may be performed by changing conduction material or reducing the quantity of wires. As it can be found in benchmark reports [93] aluminium, which has the best conductivity/weight ratio, is already in use for thick wires. The mechanical properties of aluminium, such as brittleness, do not allow it to be used in thin cables. The findings noted above constitute the evidence that, in order to reduce CO₂ emission, minimization of weight, assembly time, cost and potential exploitation issues. Is vital, and yet, cars have to be equipped with tens of safety and comfort systems, as well as systems that qualify the vehicles to exploitation, like steering systems or engine control (both in EV and CV).

One of the possible solutions is to use the same wires for multiple purposes like data and power transfer. The simplest interface which allows providing power and transmitting data on the same wires, with additional possibility of auto-addressing, can have a significant impact on the market of the automotive harnesses. As it will be demonstrated later in the thesis, interface design and optimization can be done using engineering methods. However, the issue of auto-addressing with only two wires poses many non-typical problems, therefore the author decided to use scientific methods. Auto-addressing is highly demanding due to multiple parameters to adjust, and multi-criteria assessment requires deploying artificial intelligence (AI) algorithms connected with hardware-in-the-loop (HIL) technique. Such setups are not broadly reported in scientific publications. In [16] the authors analysed most of the meta-heuristic algorithms that could be used. Finally, the authors decided to use a Genetic Algorithm (GA) to validate PID controllers. Scientists who have researched car wipers [42] also used GA in their HIL system. Similarly, GA was used to adjust the inverter in the HIL system [131]. Other groups of algorithms which were suggested in [16] were swarm optimization approaches. Particle swarm op-

timization (PSO) was incorporated e.g. to adjust PID controller of pneumatic actuator using HIL setup, in [106] researchers conclude that the approach mentioned above improves controller performance. The author decided to use both algorithms (GA and PSO) as well as HIL approach to tune up the hardware and software features of the proposed power and communication bus. Moreover, the author assumed to start finding the optimal solution by means of a variant of stratified Monte Carlo to avoid unnecessary effort of simulations and for comparison purposes as well.

The initial versions of the interface, which can be used for power supplying, communication, and diagnostics of sensors and actuators in a vehicle, were designed by the author applying a variety of engineering methods. The auto-addressing feature required advanced techniques to assure reliability. The author built and tested seven prototypes of the bus, where engineering methods were used to measure and adjust the parameters. The last version of the prototype allowed the author to observe differences in signals, but the result was very unstable, as the author could not find the proper parameters. The developed prototype was connected with a PC computer to use Latin Hypercube Sample [89] which supported the author in finding the promising configuration of the setup. However, the act of the auto-addressing part of the bus was still unstable and not reliable. On the other hand, the possibility of auto-addressing was proven. Therefore, the author decided to deploy additional genetic algorithm [91] and particle swarm optimization [29, 67] to completely solve auto-addressing problem in order to obtain robust and stable solution of the bus.

Bearing in mind the above discussion, a couple of major research tasks were identified:

1. Elaboration of a new prototyping method based on the HIL technique supported by computational intelligence algorithms to tune up the hardware and software features of the proposed power and communication bus.
2. Formulation of multi-objective optimization problem, including the proposition of the proprietary optimization criteria and coding of decision variables, as well as choosing and adjustment the main features of optimization algorithms.
3. Design and implementation of an innovative laboratory stand with the use of HIL architecture.
4. Verification studies applying selected optimization algorithms.

5. Analysis of optimization results looking through the prism of automotive industry.
6. Validation of the obtained solution in the context of its implementation potential in the DRÄXLMAIER business.

The research described in the thesis was conducted during the author's doctoral studies commenced in year 2017, in the discipline of Engineering and Maintenance, it converged with DRÄXLMAIER demand for electrical harness optimization. According to Journal of Laws of 2021, item 478, Engineering and Maintenance is incorporated into Mechanical Engineering.

1.2 Purpose of the Thesis

The main purpose of the thesis is to develop a novel power and communication bus using the elaborated prototyping method based on HIL and computational intelligence techniques. Accomplishment of the goal requires a holistic view on automotive harness from the mechanical engineering design perspective and production technology view, as well as proposition of a new concept which can potentially be implemented in the years to come.

1.3 Scope of the Thesis

Indeed, as mentioned above, the main objective of this dissertation is to develop an innovative power and communication bus using HIL and computational intelligence techniques. Hence, the novelty of the PhD project is a bus named Device Lightweight Network (DLN) which is created for allowing the transmission of data and power by means of two wires. The DLN is dedicated mainly to the automotive industry, making it possible to supply power to selected executive and sensory systems of a vehicle while ensuring their communication with the embedded control systems.

The dissertation addresses many issues in the field of mechanical engineering, including the construction and operation of modern automotive vehicles, the state of the art of automotive harnesses and the potential for their optimization, engineering applications of heuristic optimization methods, etc. The author also focused his attention on the original method for prototyping of mechatronic automotive systems based on the HIL tech-

nique supported by algorithms of computational intelligence. The whole scope of the thesis is described below in details.

Chapter one contains an introduction where the development of transportation is presented. The author pointed out that the beginning of transportation system was based on pure mechanical engineering solutions. Over the years, the mechanical engineering has given way to mechatronics with advanced communication network between systems. The current automotive market is described identifying a trend for electrification and autonomous driving. The author discussed communication interfaces and development of mechanical components, acknowledging the demand from the organization for which the author works, to optimize the wiring harness.

In one of the sections, the author describes the multiple advantages of harness optimization, primarily weight and CO₂ emission reduction. Price plays an important role as well, with the business facing increase of costs up to 1000 USD, relying on data from 2017. The author points out that CO₂ emission strongly depends on the region and a type of power plant. In the same section the author describes techniques which can be used to solve the issues, and he outlines the need for advanced computing techniques for solving the auto-addressing problem as one of the research challenges of this thesis.

Chapter two describes the modern vehicles engineering and their maintenance. The author starts from the definition of a vehicle and proceeds to power supply architectures. The chapter systematizes the names of different architectures, starts from pure internal combustion car and goes via all intermediate architectures to battery vehicles, and parallel from hydrogen through indirect architectures also to battery vehicles. The author used thorough methods to present types of car. Next, all of the types are described. The author analyses the carbon dioxide emission of all architectures in their production and exploitation. In recent years, it has been relatively easy to compare CO₂ emission due to a simple calculation from usage of unit of a fuel. However, regarding cars based on electricity or hydrogen, it is more challenging. The same Battery Electric Vehicle can emit, during a calculated lifetime, 1.8 or 46.6 Mg of CO₂, depending on the country, in Switzerland or in Poland. As it turns out, the least eco-friendly vehicle is the fuel cell car used in Poland, if hydrogen is produced by electrolysis. The author has analysed many scientific articles searching for possibilities to reduce CO₂ emissions. Regarding cars with alternative fuels, it is important to use clean energy, but that is not achievable from the position of Tier1 company, the same situation is with optimizing traffic.

The author and his employer have partially a chance to influence the points described

in following subsections, where optimizing the mechanical construction and proper architecture are described. In the last section, a bill of materials with energy consumption rate is analysed in order to define areas for optimization. The analysis of materials used for production of a car, and emission related to processing of each of them is strongly connected with Engineering and Maintenance discipline in which the doctoral thesis was initiated.

Chapter three is dedicated to the potential of optimization of automotive harness. The author describes how the harnesses are built, and what parts they consist of. The author presents the decision-making process for selecting a proper harness for further analyses. A door panel harness has been chosen, and branch requirements have been described. In the third subsection, an optimization is proposed, which is checked in patent database to prove its uniqueness. Next, the market and scientific articles have been analysed. The author has found multiple solutions how to transmit power and data on the same lines. It is remarked that solutions can be divided into two options, the first is sending data when there is zero voltage on AC power line, and the second is to 'inject' an additional signal to DC line. There was two solutions dedicated for automotive, one in real use for communication between charger and electric car, another one with declaration of using in automotive, however the author cannot find any implementation cases. The author proposes a different approach for solving the problem of supply and communication on the same line. Next the author analyses ideas for auto-addressing, there are also multiple solutions. One of them is dedicates to automotive. All of them require more cables for auto-addressing. A design philosophy of harness is introduced, the author described different philosophy of German and Japanese manufacturers. Based on the research among harness development companies, problems of this area of industry are analysed.

As a result of the conducted analyses, requirements for new interfaces are defined. Next, the author has performed a thought analysis of advantages and disadvantages of the possible solutions. Then for the first time the new interface is described. Another thought analysis has been conducted, but this time the new interface is analysed in three options as a replacement of existing architecture of harness. Nowadays, more and more companies are trying to automatize wire harness production, thus, the analysis for automatization is carried out. The author pointed out that the new solution has higher potential for optimization than the current approach.

Chapter four describes the potential methods of auto-addressing, the research stand, two layers of communication, philosophy of testing and how the research stand is built and integrated with software tools in HIL system. Next, the used algorithms are described.

The research stand requires two layers of communication, one for communication on the power wires, which is the main purpose of the proposed interface. The second layer of communication is required only in HIL system to diagnose the auto-addressing process. The author explains why wireless, radio communication via Wi-Fi and MQTT protocol is chosen. Next, the process of auto-addressing of client modules in the Device Lightweight Network is presented in details. The author explains the signals on the line, and how they are generated by master, disturbed by client and measured by master. The vector of decision variables is described and divided into seven hardware related variables, and seven software variables, while three of them describe timing and delays, four are responsible for methods of signal processing. In the next section, the auto-addressing is described based on UML sequence diagram. Then, for the first time, the research stand is presented with a picture and description. Next, the Hardware-In-The-Loop is introduced with detailed description of decision variables. Complex problems are explained using diagrams and equations.

The global multi-objective optimization problem is presented, including functions which represent the criteria for Pareto optimization, decision variables and so on. Moreover, the meta-criterion function for single objective optimization is also described. The general scheme of the proposed method is shown. At the beginning of the chapter all of the utilized algorithms are described, based on literature, and the author explains how Latin Hypercube Sample, single/multi-objective genetic algorithm and particle swarm optimization algorithms work and how their advantages were used to accomplish the purpose of the thesis.

Chapter five contains the outcomes of all used algorithms. The verification results have been divided into two groups, the one which includes the most results and another one which represents the best results. Starting the research, author expected that the best result would be contained in the outcome from the algorithm which generated the most results. Meanwhile, that expectation was achieved only by PSO algorithm, GA has given better result in a different configuration than the one which gives the majority of correct results. The author noted that in both artificial intelligence algorithms, PSO and GA, the most results and the best results have been found when the population size/swarm size had the highest number of individuals/particles. PSO gives a bit better result than GA. The worst results have been achieved by LHS, but this algorithm has only been used for comparison purposes. The author describes how the final results have been validated, as well. There have been 5000 tests of each auto-addressing setup. It is noted that two best PSO configurations, one GA and one LHS have given similar level of properly addressed

clients.

Chapter six presents conclusions yielding from the implementation of the work. The author mentions how huge CO₂ reduction can be achieved. The chapter also describes the results of using advanced computational techniques.

The work ends with **chapter seven**, where a possibility of industrialization is presented. The author regrets that because of the current silicon crisis, it is not possible to implement the obtained solution immediately. However, two proprietary methods proposed and developed by the author as part of the thesis are partly or fully implemented by author's employer.

1.4 Acknowledgments

Doctoral study was financed from the funds of the Ministry of Science and Higher Education under contract No. 12/DW/2017/01/1 of 07.11.2017 concerning industrial PhD project. The applied research described in the dissertation was realized in cooperation with DRÄXLMAIER company.

2. Modern Vehicles Engineering and Their Maintenance

A vehicle is a machine used for transporting people or goods. In the previous years, the majority of cars were built as an Internal Combustion Vehicles, but nowadays due to a global objective to reduce CO₂ emission and pursuit for alternative fuels (non-fossil), many other sources of energy can be found in the market. This area of engineering is developing very fast. Due to the new solutions, the vehicle type division is constantly changing.

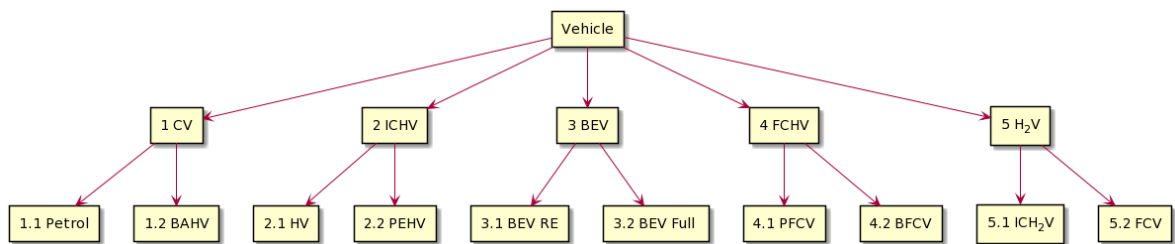

Fig. 2.1. Different Types of Power Source in Vehicles

The author proposes the division as shown in Fig. 2.1 and Fig. 2.2 where vehicles are classified as follows. The first group represents conventional vehicles (1), the classical architecture with gasoline or diesel (1.1), and battery-assisted hybrid vehicles (1.2). The second group contains two internal combustion hybrid vehicles (2), which is divided into classical hybrid (2.1) without possibility of external charging or Plug-in Hybrid (2.2). The third group represents Battery Electric Vehicle (3), which can work with range extender (3.1)¹, or without (3.2), - the pure EV. The fourth group is fuel cell hybrid vehicle (4) which can be realized as plug-in fuel cell vehicle (4.1), or battery fuel cell vehicle (4.2). The last, fifth group is powered by hydrogen (5), and is divided into internal combustion (5.1), and fuel cell vehicle (5.2).

There is no clear division of vehicle power architectures [92, 140], the author made very big effort to classify the groups according to the producers' perspective. That is the

¹from 2019 not available in EU, only in the USA - BMW i3

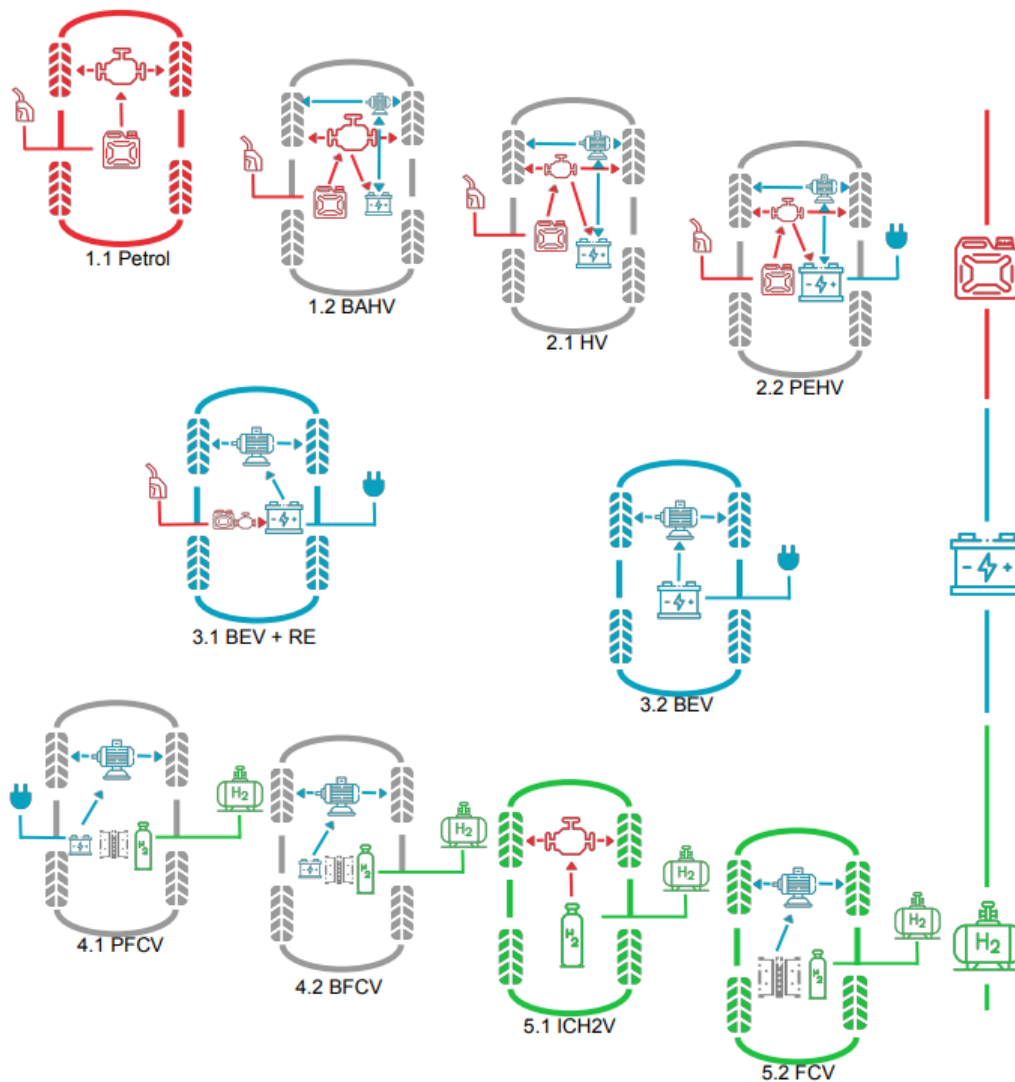

Fig. 2.2. Types of Vehicle Architecture

main reason why hybrid vehicles with internal combustion and battery assistance, can be found in conventional vehicles (point 1.2 of Fig. 2.1), or battery electric vehicles with range extender (3.1) which is classified as BEV.

2.1 Conventional Vehicles

The conventional vehicles mean cars which are very common on the market. This group was initiated by Benz in 1885 [31], and popularized by Ford in 1908 with model T [44]. From the very beginning of the automotive market, the goal was to produce cheaper and more reliable cars, which can produce more power or use less fuel - depending on the

vehicle class and region. For example, in class S (sport) and F (luxury) [33], the automotive manufactures care more to improve driving experience than fuel economy, and in class A (mini cars) or B (small cars) [33] lower fuel consumption is the main goal. Different regions in the world can buy different amounts of fuel for a monthly salary. It starts from Madagascar, where for average citizen's salary one can buy 42 litres of fuel [61], through Poland - 711 litres for monthly salary [61], Germany - 1740 litres for monthly salary [61], USA - 9762 litres for monthly salary [13, 96], to Venezuela - 133 000 litres for monthly salary [12, 47]. Ford Model T's fuel consumption 11.2 litres per 100 km [19], was an excellent result for the first mass-produced car, not as good, however, bearing in mind its top speed (70 km/h) and power of 20 HP. Even the newest cars are more powerful and faster, which influenced to their higher fuel consumption. The global fuel crisis and the increase of CO₂ emission forced car manufacturers to reduce fuel consumption. This trend transformed the automotive industry from fully mechanical designs to mechatronic solutions, by using sensors and actuators to manage the optimal fuel combustion. Each year brings new solutions. The current trend (year 2021) is to turn all IC to battery-assisted hybrid vehicles (BAHV) (point 1.2 of Fig. 2.1). BAHV architecture, named also mild hybrid electric vehicle (MHEV) in Audi, is implemented in all new cars and can reduce up to 0.7 litres per 100 km [17] or 15% reduction of fuel consumption [123]. MHEVs are characterized with a small battery, e.g. 10 Ah at 48 V, 0.480 kWh [11]. This system reduces also dust emission from a braking system, due to recuperation of the car kinetic energy and charging 48 V battery. All BAHV systems are realized by 36 V [48] or 48 V [17].

2.2 Battery Electric Vehicles

From the historical point of view, BEV (1880) [128] existed before IC (1885) [31]. Due to shortcomings of the batteries at that time, Benz invention [31] - IC vehicles became more popular. BEV was used only in special applications, especially in closed rooms like fork lifts or mining machines. Lunar Roving Vehicle was BEV type [136]. The BEV began to be developed in early nineties of XX century to be used on public roads after California Air Resources Board (CARB) [1] recommended constructing more fuel economy cars. The beginnings were difficult, the best example is GM EV1[7] there was also Chrysler TEVan or Ford Ranger EV. The range was from 53 km (Chevrolet S-10 Electric) to 228 km (EV1). The game changer in EV technology was the Lithium-ion battery [122], due to its low mass per amount of capacitated energy, and lack of memory effect [83].

The author identifies BMW i3 which manufacturers have called BEV, but it is equipped with IC generator to charge the battery. From the architecture view it is Plug-In hybrid, however the basic version of BMW i3 is fully BEV, Range Extender (RE) is only an option which can be ordered additionally during configuration of a car, but not in every country.

2.3 Hybrid Vehicles

Hybrid vehicles are the broadest concept of all. This idea is widely used in engineering and transportation, especially in heavy machines and IC trains. In automotive, hybrid means that two or more sources of energy are combined. The most popular example is Toyota Prius which uses the best from electric and petrol fuel. HV starts from solutions with minimal battery capacity like in BAHV (0.480 kWh [11]) where electric motor is connected in series with IC and only supported their work, through full hybrid, where battery is over 60 V [80] and capacity is usually below 5 kWh, to PHV with battery capacity above 5 kWh. The limit of 5 kWh was created by the legislation [21] and practical aspects.

The power consumption of electric engine is from 15.2 kWh/100 km to 23.5 kWh/100 km [121], which means that PHV can travel minimum 22-30 km only on electricity, charging a car to travel shorter distances will not be efficient. Hybrid technology allows us to use the best advantages from IC and electric motor, from electric power train, high torque and high efficiency on low speed and from IC easy and fast way to refuel the tank. Additionally, in HV, IC engine usually works in Atkinson cycle, due to the fact that in the area of bad performance of Atkinson cycle, electric motor is used, and in effect, this reduces fuel consumption.

2.4 Hydrogen Vehicles

The main disadvantage of hydrogen is storage and high CO₂ emission. I.A. Hassan and others [51] analyses all possible methods of hydrogen storage. In automotive, hydrogen is stored in type IV tank [51] at pressure 700 bars. There are few FCVs available on the market: Hyundai Tucson FCEV, Toyota Mirai, Honda Clarity FC, Hyundai Nexa. A hydrogen vehicle has two disadvantages: the lack of the hydrogen refuel stations and price of the fuel cell.

Internal combustion of hydrogen is proposed to solve the fuel cell disadvantage (BMW

H2R, BMW Hydrogen7, Toyota RX-8 hydrogen), but due to low efficiency of Carnot cycle it was not worth using such a solution, especially in scope of lack of hydrogen refuel stations.

The third and the newest option of using hydrogen in automotive is hybrid with battery and FC. Daimler [36] and Ford are carrying out the research on this technology. It can be read in [36] that Daimler has been working on FC technology for the last 30 years. There is one passenger car GLC F-Cell 4Matic [36] and one tractor Poseidon [37]. Focusing on GLC F-Cell, the car uses only 0.34 kg H₂ per 100 km, and it drives up to 51 km only on battery, 478 km on both sources, having on board 7.4 kW charger which allows charging battery up to 80% in less than 90 min. Poseidon [37] is a zero emission truck with 1000 km range, payload of 25 Mg, H₂ capacity of 80 kg, FC generates 300 kW and the battery is to provide 400 kW temporarily. The battery capacity is 70 kWh, but it is not targeted to meet the energy needs, but mainly to be used to provide situational power support to the FC, e.g. while driving uphill fully loaded or during acceleration. The electric motors can provide the peak power up to 660 kW and over 4 kNm in peak. Calculating the hydrogen capacity to the range of the truck, the consumption of hydrogen is at the level of 8 kg per 100 km. The hydrogen costs in Germany, 9.5 EUR per kg in retail and 3.8 EUR/kg in wholesale [46]. Tractors will be charged which wholesale price obtained 30.4 EUR per 100 km. It is a good economical result compared to diesel tractors which need 32 L per 100 km at cost of 49,47 EUR in Germany [127].

Taking into consideration that most of the hydrogen is produced through electrolysed water, and the efficiency of hydrogen system is at the level 30-50% [51], BEVs are usually cleaner in usage than hydrogen. It is very difficult to build a tractor with payload of 25 Mg and range of 1000 km with battery power source². Considering ecological and economical aspect, efficiency of production of hydrogen can achieve 91% [68], but is usually 50-80% [25, 138].

2.5 View on Carbon Dioxide Emission

Many car architectures are available on the market. Let us consider hydrogen production methods with potentially eco-friendly techniques like electrolysing water [138] or thermolysis [85]. While thermolysis is used mainly with geothermal energy [85], electrolysis is often carried out on hydrogen stations, and it merely constitutes 4% of global

²this goal is still not achieved, Tesla Semi comes closest

hydrogen production [138]. Therefore, electric energy is ultimately used. CO₂ emission strongly depends on sources of electric power. Research on EV done by Held [53] indicates how ecological usage of a car strongly depends on a source of electricity.

A lifespan of a car in Europe is on the level of 18.1 years in Western Europe to 28.4 years in Eastern Europe[52] due to the fact that new cars usually take longer trips, for further calculation a template of 18.1 years of life span will be used. The average annual mileage in Europe is 14300 km [53], which gives about 258,830 km of average mileage of a scraping car. A car with fuel consumption on levels of 10 L per 100 km for gasoline, 6 L per 100 km for diesel engine and 11 L per 100 km for LPG emits respectively 22, 16 and 17 kg of CO₂ for each 100 km[95]. In a lifetime, it gives 57, 41, 44 Mg, for a compact BEV with energy consumption 23 kWh per 100 km will and 18 kg of CO₂ for each 100 km in Poland (47 Mg lifetime), 9 kg of CO₂ will be emitted for each 100 km on average in EU-27³ countries (23 Mg lifetime) and 0.7 kg of CO₂ for each 100 km in Switzerland (2 Mg lifetime).

The growing market of HEV seems to be the best option for most countries, due to its low fuel consumption (average about 5.3 L per 100 km [3]) and a wide range of gas stations. CO₂ emission of HEV is 12 kg of CO₂ for each 100 km.

2.6 Vehicle Architecture Comparison

Depending on the car architecture (IC, HV, BEV, FCV, others) and the size of a car, different amount of energy is consumed to produce a vehicle, according to the analysis conducted by Kosai et al. [77] based on research results released by Japan Automobiles Research Institute [58]. The least energy and rare earth metals are used for production of a CV - about 143 GJ per car, followed by HEV with 154 GJ per car, then is BEV with the usage of 235 GJ per car, and finally FCV with 268 GJ per car - almost doubling CV.

To compare all architectures and to identify which element of the vehicle is responsible for this significant growth of energy demanded for production of a vehicle, the author decides to compare CV with other architectures.

HV, due to similar components with an additional small battery system, can be characterized with not a significant increase in energy needed for production. Contains about 4 times more copper (57 vs. 13 kg) due to electric motor and high-power cables. Additionally, there are components of the battery, mainly N-methyl pyrrolidone (NMP), an impor-

³EU-27 determines all countries which belong to European Union [2]

tant material for lithium battery production. Characterized by high polarity, low volatility and low toxicity, NMP has the advantages of good chemical stability and thermal stability - 6 kg [129].

BEV is a vehicle with entirely different architecture, lack of catalyst containing rare earth metals is compensated with a much bigger battery than in HV. Such a car contains about 8 times more copper⁴ (103 vs. 13 kg) due to its big battery, powerful electric motor, high-power cables. Additionally, like with HV battery components, mainly NMP, cobalt, lithium - together the three components weigh 20 kg and require 99 GJ to produce.

FCV is an underdeveloped technology, however, of higher potential. Current FCVs on average weight 1850 kg, therefore, they are the heaviest cars on the market. on average, CV's, a heaviest BEV's and HV's weights are 1140 kg, 1563 kg and 1380 kg respectively. FCV contains the highest amount of copper (120 kg). BEVs are often criticized due to cobalt, but FCV contains more cobalt (3 kg vs. 0.9 kg in BEV). FCV is also characterized with the highest share of resins (171 kg). Together, cobalt and resins in FCV require 157 GJ for producing a single car.

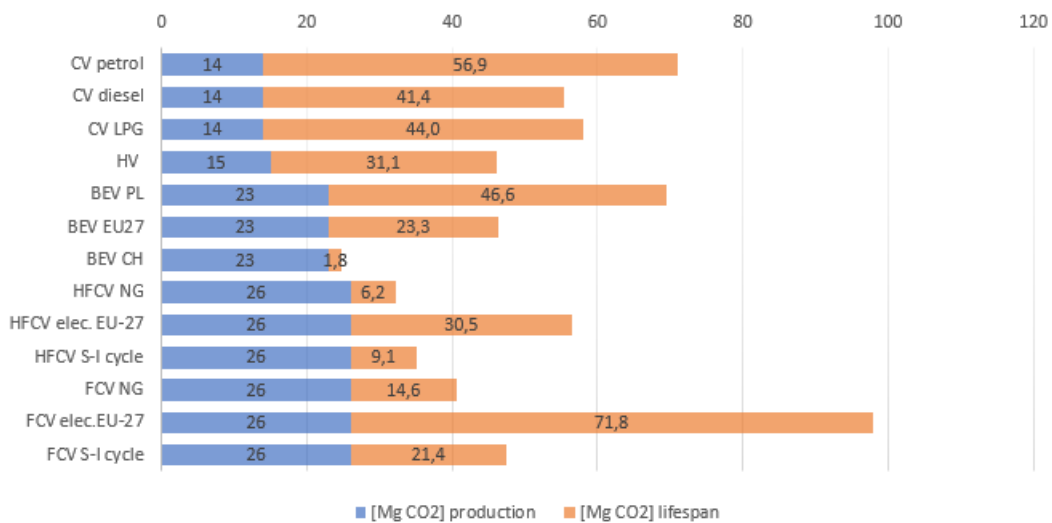

Fig. 2.3. CO₂ Emission in Different Architectures and Fuel Sources

Depending on the country where the production is located, the CO₂ emission can be varied. Due to scattered global production and extraction of raw materials in the whole world, it is impossible to calculate the precise CO₂ emission per single car. It is also likely that the same part is produced in two different factories in different countries, with different energy mix, which may affect the final CO₂ emission per production of a single car.

⁴copper required 21 MJ energy for production each kg of material

Because of the global trend to move production to lower labours cost locations, where usually energy mix contains more fossil fuels, assumption energy mix on the level of EU-27 will be most likely the best-case calculation. The approach of companies like Dräxlermaier, which decided to use only green energy for their production [66], can bring the EU-27 value of CO₂ emission per 1 MWh closer to the value of production of a vehicle. Computing 350 kg CO₂ per 1 MWh, production of a car emits 14 Mg for production of a CV, 15 Mg for a HV, 23 Mg for a BEV and 26 Mg for a FCV. The a comparison between different architectures and fuels is shown in Fig. 2.3 where, BEV PL means BEV charged with Polish energy mix, BEV EU-27 stands for BEV charged with EU-27 energy mix, BEV CH is a BEV charged with Switzerland energy mix, NG show CO₂ emitted by hydrogen produced from natural gas, elec. EU-27 represents hydrogen produced by using electrolysis with EU-27 energy mix, S-I cycle is hydrogen produced in S-I cycle.

2.7 Reduction of Carbon Dioxide Emission

Analysing section 2.5, it is to become obvious how important clean electric energy production is. The energy sector is responsible for 73.7% of world CO₂ emission [103]. As it can be seen in Fig. 2.4 transport is responsible for 16.2% emission which gives a great opportunity to achieved real reduction of global CO₂ emissions. Reduction of CO₂ can be achieved in multiple ways, which is analysed in details in following subsections.

2.7.1 Reduction by Clean Energy

Clean energy can reduce a carbon footprint and has significant influence on further market development. A growing number of companies are using CO₂ reduction as a marketing tool [66, 116]. For instance, a delivery man travels up to 337 km with average maximum speed of up to 54 km/h [23], a perfect area for an electric car option. Additionally, delivery work is done only during daytime (excluding hub-hub trips), and thus the cars can be charged with cheap night tariff electricity. The annual CO₂ emission is growing by average 2% per year, while shipping industry emits 1.7% of global CO₂ [103].

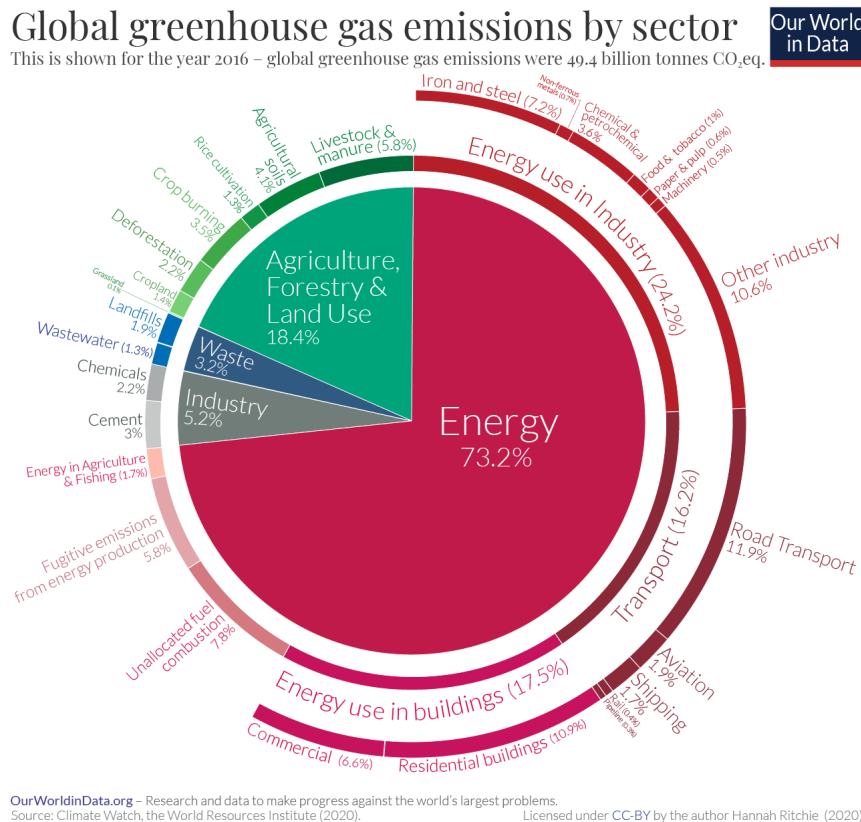

Fig. 2.4. Global Greenhouse Gas Emission by Sector [103]

2.7.2 Reduction by Optimizing Traffic

The second way of reduction of CO₂ emissions is via optimizing road traffic. Responsibility can be shared by two institutions, road administration and vehicle manufacturer. Road administrator can design roads and road obstacles in a way favourable of CO₂ emission reduction. Pérez-Martínez et al. [101] analysed the influence of highway toll system on CO₂ emission. Free flow toll system can reduce CO₂ emission on gate from nine times for a car or van to twenty-one times for trucks.

German Association of the Automotive Industry analyses the influence of stops and acceleration of a truck on fuel consumption [127]. The results are significant, a truck travelling 50 km/h consumes about 28 L per 100 km. If the truck has to stop twice on each kilometre, the fuel combustion increases to 84 L per 100 km.

Car manufacturer can optimize vehicle architecture to reduce CO₂ emission. It was proven that new types of engines, power trains, tyres reduced emission by 30% [127]. Incorporating hybrid technology reduces passenger car emission by almost a half when

compared to the CV. The next step of optimizing each trip is autonomous driving[41].

2.7.3 Reduction by Optimizing the Vehicle Construction

The biggest impact on a fuel consumption is caused by the mass of a vehicle. The forces corresponding to acceleration and deceleration, as well as other components of resistance forces acting on the vehicle can be significantly compensated or reduced by hybrid technologies, but the rolling friction has always the biggest influence, according to the following equation [121]:

$$F = \sum_i F_i = \frac{f}{R}mg + \frac{\rho}{2}V^2C_xA + \dots, \quad (2.1)$$

where F is the total resistance force, F_i is the i -th component of resistance force, ρ is air density, V is velocity, C_x is aerodynamic drag coefficient, A is front area, f is dimensionless rolling resistance coefficient, R is radius of a wheel, m is mass of a car, g is acceleration due to gravity, ... denotes other less significant components of resistance forces.

The first element of Eq. 2.1 is responsible for a rolling friction in which the required force to move an object is proportional to the weight of an object. The mass of the vehicle can be reduced in multiple ways, one of them is optimizing the car body construction using as thin metal sheets as possible, changing materials to lighter one, for example replacing steel by aluminium (engine blocks) or by magnesium (car trunk flap, suspension). The author proposes to optimize harness which can weight up to 91 kg, in some areas of the harness its mass can be reduced up to 38%.

2.7.4 Reduction by Proper Architecture

The carbon dioxide can be also reduced by proper architecture of the vehicles. Choosing a proper energy source for car specification is crucial. It is difficult to compare existing vehicle because not optimal solutions are cancelled during validation the mathematical model. One of the best example is truck Dumper produced by eMining AG [43] which uses a battery-powered dumper for uphill stone mining. The dumper is charged driving downhill with excavated material, and uses the energy driving with empty dumper uphill.

Using the Eq. 2.2 a 1.4 Mg diesel vehicle, compared to 40Mg tractor should consume

1.12 l/100 km or even less when the aerodynamic forces will be addressed. Daimler offers two vehicles designed in the HFC technology. The influence of architecture can be analysed on scale of the passenger vehicle and 40 Mg tractor Daimler GLC F-Cell 4Matic and Poseidon, with efficient recuperation of kinetic energy during deceleration. GLC F-Cell 4Matic uses 0.34 kgH₂ per 100 km vs. Poseidon 8 kgH₂ per 100 km. From the proportion of fuel consumption expressed by the equation:

$$\frac{M_1}{f_1} = \frac{M_2}{f_2}, \quad (2.2)$$

where M_1 and M_2 represent masses of vehicles, f_1 and f_2 correspond to their fuel consumption, the mass of GLC F-Cell 4Matic can be calculated as follows:

$$M_2 = \frac{M_1 \times f_2}{f_1} = \frac{40 \times 0.34}{8} = 1700kg \left[\frac{Mg \times l/100km}{l/100km} \right]. \quad (2.3)$$

This is a standard weight of fuel cell cars and SUV class. The above calculations can be used to prove the usage of BEV and HV technology.

Classical IC 40 Mg load tractor consumes about 32 L per 100 km [127]. Using the same proportional calculations given by Eq. 2.2, it may be shown that a passenger car has to burn maximum 1.5 L per 100 km of Diesel. In such juxtapositions, the same type of fuel has to be maintained, due to different efficiency of IC engines.

2.7.5 Bill of Materials Analysis

Analysing materials used to build a vehicle [77], the author considered only those over 1 kg of weight in a single car. Lithium and cobalt bear the highest energy consumption rate (ECR) 9.2 and 7.5 GJ per kg, followed by semiconductors and numerous kinds of plastics and resins which are lightweight materials compared to metals, or are used as electrical insulators, for example in cables or electronics. Magnesium with ECR 1.5GJ per kg can be replaced with other metals, but due to its low density (1.7 g/cm³ [14]) it reduces fuel consumption during life cycle. Other metals are chromium used as decoration and also in higher volumes in catalyst [64], nickel, often used in lithium batteries [110], finally there is automotive harness, where ECR is 188 MJ per kg.

Harness is built from many elements, the main are copper (ECR 21 MJ per kg) and thermoplastic (ECR about 400 MJ per kg - depend on plastic). In standard cables insulation is made of thermally stabilized PCV [9] which is responsible for ECR 53,2 MJ per kg [98] where for EU-27 production, is generating 2,04 and 5.17 kg CO₂ per kg of product. Cables in automotive are built according to the norm DBL 6312 AA01.

Production of a harness in automotive requires 4 - 17 GJ of energy, which equals to 1.1 - 4.7 MWh and as a consequence it leads to 385 - 1650 kg CO₂ for EU-37 production or even 3605 kg CO₂ if the harness and cables are produced in Poland.

Analysing materials used for production of a car, and emission related to processing of each of them, is strongly connected with Engineering and Maintenance discipline in which the doctoral studies were initiated.

2.8 Conclusion

As it is shown in the chapter, modern vehicles engineering and their maintenance need multidisciplinary knowledge corresponding to different types of a vehicle architecture such as CV, BAHV, ..., carbon dioxide emission and its reduction, etc. At the same time, the special attention has to be paid to bill of materials analysis. The result of such analysis shows that the automotive harness plays an important role in the total amount of CO₂ emission generated during production of a vehicle. Hence, modern vehicles design and maintenance has to take into account the potential for optimization, which is described in the next chapter.

3. Potential for Optimization

This chapter deals with proving evidence that the proposed DLN idea has the potential to fulfil defined requirements. This is interpreted as the potential for simplification of an automotive harness leading to reduction the weight of a car, and consequently to reduction of resources used to build the vehicle in order to decrease CO₂ emission during production as well as on exploitation of a vehicle.

3.1 Automotive Harnesses

Nowadays, Original Equipment Manufacturers do not distribute wiring schematics. Such a real harness schematic is required to show the benefits which can be obtained by optimizing harnesses in a vehicle. The first step is to select the area of the harness. Typically, harnesses are divided into sections. The biggest one is the main and cockpit harness [93]. Smaller harnesses are used for centre console, engine, bumpers and doors. It seems obvious that the best option is to analyse the holistic harness. However, such tasks are usually developed by a team of engineers over a few-year span [79], which makes it impossible in a very short period of time to perform reverse engineering of existing harness by a single person.

The author was constrained to select small multi-element harness. The main and cockpit harnesses could not be selected due to their complexity, whereas bumpers and engine harness do not qualify because of their lack of technological diversity. The author's choice was between centre console and door harness. Due to a wide variety of components in a door panel, like high-power cables for window lifter, elbow warmer, audio cables for speaker, multiple switches and lighting, the door harness was selected. To increase the number of distinct signals in analysing, the driver's door harness was chosen. The last step was to choose a car model to be analysed. Therefore, a high-class car was selected due to numerous of new technologies implemented. Having reviewed after-market availability of a relevant harness, the Mercedes S class driver's door harness was singled out, model W222, see Fig. 3.1.



Fig. 3.1. Mercedes S-class W222 Door Harness

3.2 Harness Analysis

After having the harness taping disassembled, a schematic was drawn, which was followed by full disassembly of the harness to juxtapose the percentage ratio of each component. The cables have the largest mass share (50.5%), connector housing (12.6%), cable tray and taping (15.2%), assembly elements (12.2%), contacts (4.4%), and others.

Conceding cable types, the door panel was equipped with three different LIN interfaces. Two of them connect the door panel device with the main connector, one of the devices for blocking door locks, another for car seat adjustment. The third LIN connects ambient light. The door panel is equipped with three ambient light modules. These modules can be auto-addressed and have four cables, two for power delivery, the first one for LIN_in, the second for LIN_out. For cost reduction, Daimler, decided to solder cables to ambient light modules, to avoid connectors. Such a solution reduces cost in general but requires additional process (and machines) to crimp two cables in a harness, e.g. to connect power, grounds or LIN_in with LIN_out. Usually, connections of two wires are made inside one crimp in the connector (excluding IPxx connections). Ambient lights modules are equipped with auto-addressing feature, which means that all modules are the same, most probably the ambient light provider delivers modules with the same cable length. In the analysed harness, every module has different length of cables, which most probably means that the cable is cut on harness production site. To produce such a simple harness, minimum 5.23 m of scrap cable is generated for each door panel, however, due to a lack of evidence, it will not be counted in potential optimization. Modern car like W222 still has many classical signal cables, 20 of such cables were identified in the door panel. A detailed summary of all cables was included in Tab. 3.1.

From norm DBL 6312 AA01 it can be calculated that 0.13 mm^2 cable is built in 45% of

Tab. 3.1. Cables Thickness in Door Panel

Interface type	Cable thickness [mm ²]	Cable length [m]	Number of cables	Crimp connectors	Soldered connectors
LIN RGB	0.13	5.7	13	7	12
LIN1	0.13	0.5	1	2	0
	0.35	1	2	4	0
LIN2	0.13	0.83	1	2	0
	0.35	1.66	2	4	0
Signals	0.13	1.55	3	6	0
	0.35	6.42	9	18	0
	0.75	1.52	2	4	0
Sum	0.13	8.58	17	17	12
	0.35	9.08	13	26	0
	0.75	1.52	2	4	0

PCV (percentage is related to the mass), and thicker cable 0.75 mm² only in 21%. Summarized materials in door panel cables, total 51.5 g of copper (Cu) and 22.8 g of PCV.

3.3 Proposal of Optimization

The author's proposal for harness optimization consists of a new interface to automotive. The author assumes transmission of power and data on the same line. The author analysed the market, relevant patents and scientific publications. The ideas of reducing the number of wires are popular, but each of them has disadvantages that cause problems in automotive applications.

Almost all patents related to transmitting data over power line which were analysed can be divided into two groups, injection of a noise to the line or use of polarization change on AC (alternating current) network, where voltage is close to zero, to send a data. The author identified only one patent US 8659181 B2 [28] dealing with the invention which allows generation of interrupts on DC (direct current) power to transmit data.

Transmitting data on power lines is commonly performed in home power grids by

special equipment which allows replacing Ethernet cable (e.g. TP-Link TL-PA4010). Such a solution is also described in norms like PN-EN 50090-1 for Poland or EN 50090-1 for Europe.

There are only two, not very popular though, solutions in automotive industry using the same wires for transferring power and data. These can be characterized as follows.

1. Company Yamar [135] proposed special chips to “inject” multiple interface to power line. Depending on a chip used, the user can achieve data speed from 9.6 Kbps to 500 kbps. Such a solution has a few disadvantages: it is not economical (7 EUR for CAN chip) minimalistic approach (mainly peripheral components, coils, capacitors, and one crystal resonator). One of the goals of hardware engineer who designs a new device is to use as few components as possible, for three reasons: more elements generate higher manufacturing costs (component cost, assembly, maintenance), potential issues (hidden defects, production issues, supply chain issue), size (each element requires more space on the PCB - Printed Circuit Board). Researchers [118] attempted to transmit data using the oldest solutions from Yamar (Yamar SIG60) with no satisfactory results — the interface was working, but it was relatively slow — only at 57.6 kbps when no transmission errors occurred. Unfortunately, there are no studies with the newest solutions from Yamar.
2. A number of standards for communication between a car and charger. The first one is open charge point protocol (OCPP) [5]. Other protocols include IEC 63110 - protocol for the management of electric vehicles charging and discharging infrastructures, ISO 15118, one of the IEC standards for electric road vehicles and electric industrial trucks and ISO 61851 - international standard for electric vehicle conductive charging systems. The standards mentioned above are based on the same technology as Yamar standard, with its all disadvantages.

In the industry, we can encounter an AS-I [32] interface, where data and power are transmitted on the same line. Voltage on AS-I line is 12 V, and the baud rate is low. The transfer is not expressed in bits per second. AS-I can check status of 62 nodes in 20 ms. One of the oldest commonly used interface that uses only ground and a single wire to deliver power and data is "1 Wire" introduced by Dallas Semiconductor, known today as Maxim. These two solutions are characterized by low baud rate. Moreover, 1 Wire bus acts with low-power delivery which is equal to 1 mA.

When it comes to small devices which are commonly used in a car (e.g., ambient light, sensors, actuators) OEMs have three solutions:

- using separate wire to each device (it increases cost, weight and geometrical sizes of the harness),
- same hardware but different software, where address is programmed (it increases effort during production, risk of mixing devices of the same shape),
- auto-addressed modules on the line.

There are few solutions for auto-addressing available on the market. One of them is solution from Melexis [90]. Where between LIN_IN and LIN_OUT pins, there is a shunt. LIN signal from master is connected to the first LIN_IN client, from this client LIN_OUT is connected to LIN_IN from the second client and so on. On master LIN_OUT is connected to the ground. The voltage on LIN line is measured, the highest voltage means that this module is closest to the Master, each subsequent lower voltage means the next position on the line.

Another solution is from Texas Instrument [15] named "Automatic Slave Node Detection". Only one line of LIN is used, however, an additional signal which has separate input (RX) and output (TX) on each node is required. An additional signal on master is connected with ground. The client senses that its RX pin is low, accepts ID which is sent by master and burns it into the EEPROM space that is reserved for ID. Then the slave device switches the TX pin to GND. This cycle repeats as long as all modules received an address.

A patent describing auto-addressing [102] is available for RS485 [20]. This idea requires the highest number of cables (input and output) from each module's. Power supplies are connected in parallel, lines from RS485 (signals A and B) have separate inputs and outputs, which gives four cables in a wire harness and six pin connector to each client. For auto-addressing all modules disconnect, connection between input and output cables. A master sends the address which can be received only by the first one, after the ID is burned into the EEPROM, the addressed client connects inputs with outputs. The patent provides deployment of transistor or relays for connection and disconnection.

All solutions require multiple wires, commonly with an additional one, which gives four lines including power supply.

Developing a harness is a complicated task. Different markets rely on their processes,

e.g. German manufacturers work on the basis of KSK¹ while the Japanese manufacture with a higher degree of standardization [79]. The German approach requires more planning, and effort to design a harness, whereas the Japanese approach reduces the development time but increases the cost of a final product due to not using all cables in the assembled harness.

Harness is a critical safety element of a car [86] however, ISO26262 [8] does not contain any information about requirements for harness [79]. Development of a harness has been a balance between safety and costs over the last 20 years, not many changes have been implemented to the production and development processes [79]. According to an open-question survey conducted among a group of harness manufacturers, 9 out of 11 of them mentioned that change management is one of the biggest shortcomings [79]. Due to the survey's open-question format, it can hardly be justified that for two of the survey respondents, change management does not pose a big problem. According to the literature [79], engineers have to implement about 1000 adjustments a month, the process of which accounts for 80% of their time. Such a significant number of modifications can lead to many errors, and according to the same literature, 80% of the failures are corrected after the start of production (SOP). The information is far from optimistic in perspective of autonomous driving (AD) due to a high-safety oriented architecture.

From the management's perspective, harness development is interdisciplinary. Its production is fully mechanical, however, the grounds for developing a harness is a wire net-list, which is an electrical area. Researchers have been analysing the market needs and trends [100]. The author predicts that the next year will bring a huge change in approach to managing harness design. This area of engineering is adopting more, and more tools currently used by software industry. A growing number of researchers are examining the follow-the-sun concept [27, 109]. As it was mentioned above, harness development is excluded from ISO26262 [78], but this industry has been deploying several requirements from Functional Safety (FuSa) like redundancy in safety critical aspects. But due to autonomous driving requirements, more and more traceability is required [79].

The author and his employer have intended to develop an interface to transfer power and data on the same line. The idea of the solution is to determine time frames for power transmission as well as for data transmission. There is also a high necessity to develop an auto-addressing method for modules on the line. A complex device of that kind would reduce workload for mechanical engineers designing a 3D shape of harness, and spare

¹KSK - Kundenspezifischer Kabelbaum - is German well known among European OEM's and harness manufacturers

many materials used for the production.

3.3.1 Assumption of Desired Solution

Considering all of the above information, an analysis ought to be conducted, and the company needs be defined. The goals which cover all needs to be explicated.

Two meta goals of the proposed solutions have been defined:

- New interface should fulfil the electrical requirements:
 - ability to work with 12 V with perspective to 48 V,
 - current supply min 2 A,
 - baud rate: min. 512 kbps,
 - auto-addressing ability.
- Optimize harness by reducing the number of wires, deploying one pair of wires for multiple purposes, where following requirements have to be met:
 - CO_2 reduction,
 - mass reduction,
 - production time reduction.

The solution will cover most of the reducing the connection between main electronic control units and client devices in a car, owned by the author's employer.

The option of reliable work with multiple voltage can be beneficial when e.g. 12 V door glass lifter is connected to the very same line as the other devices. In case of 50% data time, the voltage has to be higher to get the effective 12 V. Nowadays, cars are frequently equipped with 48 V batteries. Connecting such a battery with 12 V electric lifters, requires pulse with modulation (PWM) control with 25% filing. Cables between battery and engine can be four times thicker, due to the low average current.

The current supply at the level of 2 A gives 24 W at 12 V and 96 W at 48 V of line voltage. It is enough for most of the applications. The author will keep focus on designing master in such a way that voltage and current on the line will not be depending on the architecture. The informal goal is to change only the main transistor to high or high-power voltage.

Baud rate at the level of 512 kbps is sufficient for sending simple information, for sensing video signals or other similar CAN FD [81] or automotive Ethernet [78] is applied.

Some equipment in the car is used multiplicatively in one car, like ambient light modules. Caberletti et al. [26] remarked in 2010 that there were roughly 25 ambient lights in a car. Today, this number is a few times higher. It should be also noted that, auto-addressing significantly reduces the production effort.

3.3.2 Proposal of New Solution

There is no relevant solutions on the market to fulfil all requirements from the previous section. Each technique can be characterized by both advantaged and disadvantages. The systematization of possible solutions can be seen as follows:

- Sending data during polarization change.

This is an old techniques, with low baud rate, and it can be used only in AC power lines (in automotive DC is used).

- Add additional signal to a DC power line.

It is a widely used solution.

– Advantages:

- * well-known technique,
- * available chips on the market, even with automotive qualification,
- * lack of constraints to voltage and current.

– Disadvantages:

- * expensive chips,
- * multiple additional RLC required,
- * large area on the PCB for transceiver,
- * no possibility of auto-addressing.

- Splitting power signal to transmits power and data

– Advantages:

- * potential for auto-addressing,

- * high baud rate potential,
 - * small constraints to carry voltage and current,
 - * potential for small area on PCB.
- Disadvantages:
- * lack of the solution on the market - lack of experience,
 - * potential patent violation,
 - * need to design the interface from scratch,
 - * success is not guaranteed.

It seems obvious that choosing the third point is optimum. At the beginning, patent US 8659181 B2 [28] has to be analysed. The first part described the state of the art, where the author mentioned popularity of injection a data on to AC or DC signals, all defects were listed. Then in the chapter "SUMMARY OF THE INVENTION" the electrical layer is described. The goal of this invention is to have possibility of adjustment T_{off} - time for sending data, and T_{on} - time for carrying power to the loads. During T_{off} only ten bits can be transmitted. The author proposed a solution how to reduce influence of the noise, increasing amplitude of a signal, without changing a power of the pulse. Dirac delta with high amplitude can generate Electro Magnetic Compatibility (EMC) issues. The T_{off} is divided into ten periods, if during such a period Dirac delta occurs, the receiver will interpret it as logical true.

Due to high automotive standards, the author has to consider EMC from the very beginning. Additionally, due to potential noises, the signal has to be recognized as logically true only if the voltage is within specific range. The data signal has to rely on low amplitude to maintain the potential of high baud rate. The signal has to be also based on rectangular waveform. Time for data (T_{off} from patent) has to be defined by the user, as well as baud rate. The user will be able to fully configure the interface to his needs.

The author proposes a new interface — DLN (Device Lightweight Network) which is also described in [119]. DLN allows us to use only one pair of cables to transfer data and power, the goal is to implement auto-addressing. The first DLN version was characterized by the following parameters: data link up to 2 Mbps, voltage up to 48 V and current up to 10 A. The data is transferred during small breaks in power delivery. Data is transferred on low voltage (about 2 V) to avoid electromagnetic interference (EMI). Power is on much higher voltage (9 V - 48 V), as the example with 24 V supply in Fig. 3.2.

Power and data delivery time can be adjusted depending on whether higher data rate

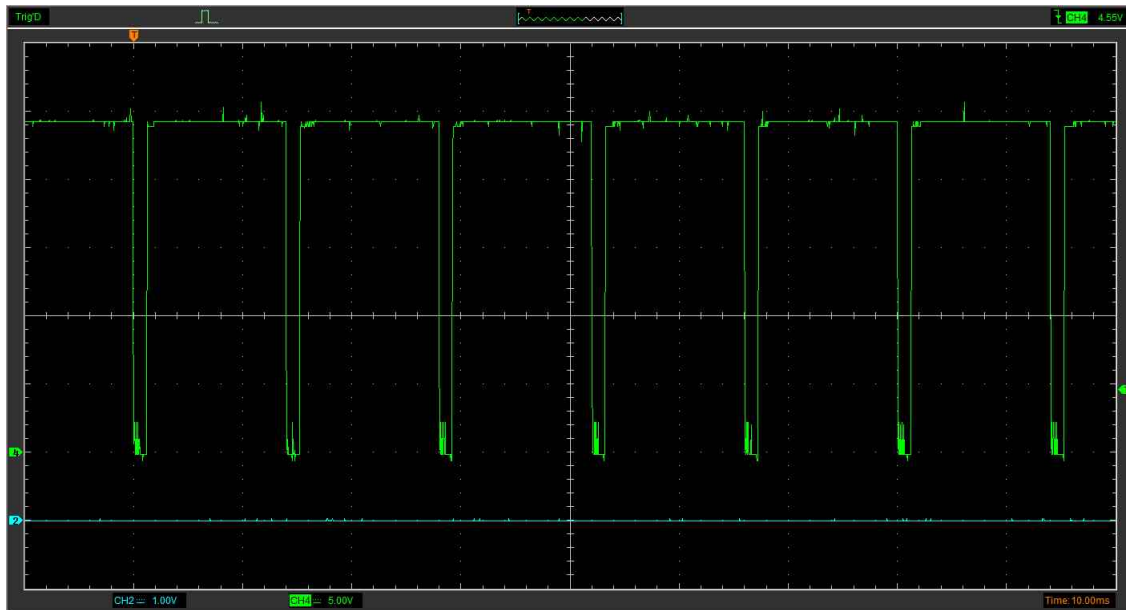

Fig. 3.2. Oscillograms from Transmission Line

or more power is anticipated. Figure 3.2 presents an example of transferring high power (1.2 ms for data, 12.8 ms for power in each period), where high-power lamps, electric heater and two electric motors are supplied (Fig. 3.3).

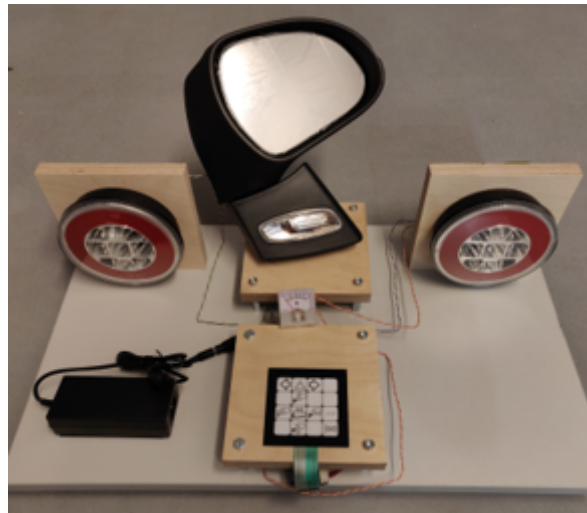

Fig. 3.3. Proof of Concept of DLN Solution

The figure 3.4 presents signals on the lines of the interface, one line is always used as a mass and cannot be replaced by car body mass, the second line is used to transmit power and data on different voltage level. The details of communication and auto-addressing are shown in Fig. 4.1.

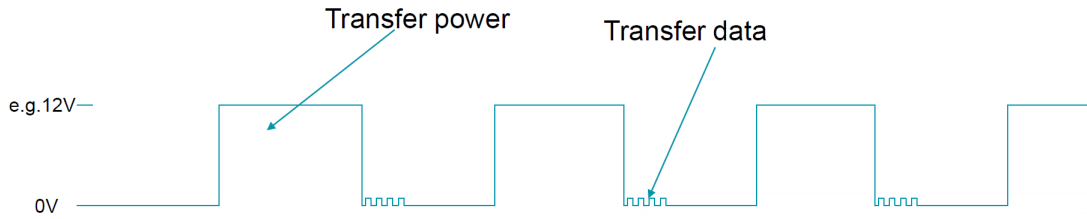

Fig. 3.4. DLN Signal Waveform

A proof of concept was built, where lamps and side mirror are controlled. The side mirror was equipped with two electric motors and an electric heater. The network that was built operated perfectly, even while the devices were controlled simultaneously, and the maximum current consumption was 6 A. The protocol was calibrated using engineering methods (Fig. 3.3), which means classical calculation and hardware laboratory equipment was used.

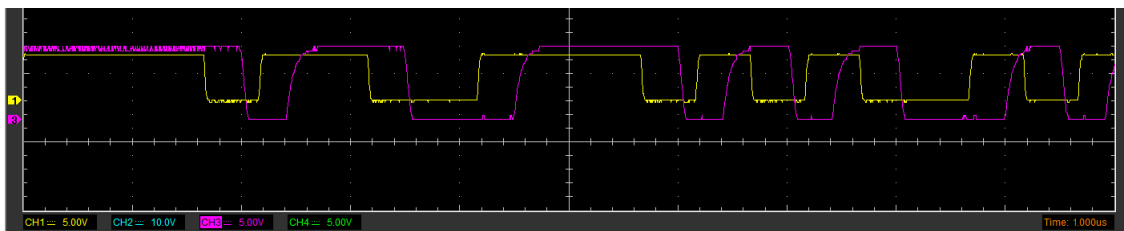

Fig. 3.5. DLN Signal at 2Mbps

The bus was developed with much better parameters than expected, it is up to four times faster (up to 2 Mbps, where 512 kbps was the target), see Fig. 3.5, and can transfer up to 480 W (48 V and 10 A) where minimal goal was set to 2 A. Mainly 4 channels oscilloscope was used to synchronize all signals on one board, master or client. Additionally, to synchronize master and multiple client, LEDs on each board and camera with 480 fps was used. Such a simple camera allows for galvanic isolated logic analysing on 369 channels (with potential to thousands) at time resolution in the range of 2 ms.

Further, conventional engineering approaches were no longer as effective. That is why the HIL setup and computational intelligence techniques are required. More details are presented in chapter 4.

Tab. 3.2. Optimization Scenarios Comparison

	thickness [mm ²]	length [m]	quantity	Cu [g]	PCV [g]	CO ₂ prod. [g]	CO ₂ reduction [%]	CO ₂ reduction [%]
Current	0.13	8.58	17	10.3	8.6	65	-	-
	0.35	9.08	13	30.3	11.2	119	-	-
	0.75	1.52	2	10.9	3	38	-	-
WC	0.13	2x2.08	4	5	4.1	32	52	19
	0.35	2x4.14	5	28	10	110	8	
	0.75	2x0.76	1	10.9	3	38	0	
STD	0.13	2x2.08	4	5	4.1	32	52	33
	0.35	2x3.01	5	20	7.5	80	33	
	0.75	2x0.76	1	10.9	3	38	0	
BC	0.13	2x2.08	4	5	4.1	32	52	39
	0.35	2x2.5	5	16.8	6.2	66	44	
	0.75	2x0.76	1	10.9	3	38	0	

3.4 Analysis of the New Concept

Many optimization techniques of DLN can be adopted. The author has decided to analyse three cases, the worst case, the best case and standard, which maintain an equilibrium between reduction of all possible costs and divide harness into separate purposes. The worst case (WC) of optimization is connecting each single module with a separate DLN line. The standard (STD) optimization is to replace each communication line with separate DLN, I/O signals with four DLN, and high-power arm heater with fifth DLN. The best case (BC) will use two DLN, one for ambient light due to separate auto-addressing, the second one will connect main connector with arm heater with 0,75 cable, and next using 0,35 cable other devices will be connected. For BC comparison with the same topology of a harness will be used, which most probably will extend the cable length; however, the goal is to analyse replacement of a harness not constructing Mercedes door from scratch. The comparison is presented in Tab. 3.2.

It depends on adopted optimization how significant reductions of materials will occur as well as, CO₂ emission and costs. It can reduce from 19% to 39% of CO₂ or from 27% to 44% on used cable (counting one meter of twisted pair as 2 meters of single cable). The mass reduction of copper can be up to 36% and PCV used for insulation up to 42%.

Assuming that, for comparison, meters of cables will be taken, where one meter of twisted pair is counted as one cable, and LIN will be counted as 3 due to current approach of usage of three separate cables. The proposed harness can be characterized by 63% to 72% reduction of wiring. The Author has not enough knowledge to estimate production time reduction, but due to reduction up to 72% of cables, the reduction for time required to production will be significant. Additionally, for the proposed harness, less tape for taping will be used and connectors will be smaller.

To prove correctness of the above calculations, a method of auto-addressing has to be developed.

3.5 DLN in Future Use

The proposed DLN is not designed as safety critical, due to lack of requirements corresponding to ISO 26262. Nowadays, for safety critical aspect, two redundant interfaces are used. DLN can be used in the same way, still keeping their benefits - possibility to reduce the number of cables and sizes of the connectors. Using one twisted pair of cables also reduces effort of changes management, due to the fewer number of cables. Twisted pair of cables is treated by CAD software as one part, compared to LIN or CAN it gives 3-4 times less effort, according to the amount of reduced wiring.

3.6 Automatization of Production

The simplification of the harness design opens an opportunity to automatize the production. The state of the art of harness manufacturing is mainly hand work [125]. In the literature, that can be even named as "human-in-the-loop" [105]. From the survey, conducted among harness manufacturers a conclusion can be derived that no significant changes have been recognized over the last 15 years [79]. Nowadays, more and more automatization is implemented to harness production; however, the major work is still performed by humans. Preparation to harness production is fully automatized. Cables are cut and crimped by machines, meanwhile workers run cables on fork-tables, see Fig. 3.6. Operators are responsible for the layout of the cables, optical fibres, coaxials, ties, hydraulic and pneumatic pipes. Next, cables have to be inserted to correct connector, where the system checks correctness on the fly. At the end, the harness is taped and holders are attached to it.

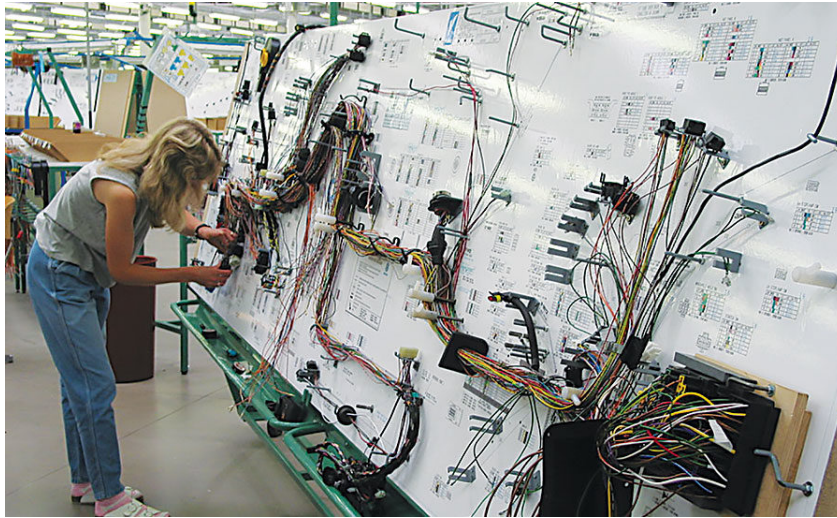

Fig. 3.6. The wire harness paced assembly table [115]

Manufacturers would like to automatize the production process, but automotive harness is highly complex, its flexibility forces machine manufacturers to install many camera feedback devices [76]. The biggest connectors contain up to 96 cables in 4 rows. It is difficult to build a machine which can insert a single cable to a connector. Only two families of harness manufacturing machines have a feature of that kind [74]. With each cable in a connector the difficulty level is growing - cables are usually smaller and smaller, the accuracy of the machine has to be higher, and finding the correct hole in the connector, in the environment of tens of other cables is challenging.

The main supplier of harness production machines is Komax [74] and Schleuniger [107]. Both of them offer advanced machines which can cut, strip, insert a seal and attach a terminal. Additionally, Komax "Zeta" and "Omega" can also insert a single wire to a connector and Komax Sigma 688 can twist a pair of cable, but cannot insert such cables to a connector [73].

The author cannot identify any stock machine which can insert a twisted cable to a connector. Komax "Zeta" and "Omega" [74] can insert only a single cable to connector. To work with twisted cables, the gripper and turntable have to be heavily redesigned.

The global leader of automatic taping is KabaTec [62] which is a part of Komax group. There are many tools and machines to tape a harness, from hand taping tools to fully automated ones with up to 200 programs for taping. The KabaTec with its subcontractors like Unitek [6] can build a customized solution with tape dispenser on the industrial robot arm. Such a solution is a big investment but generates much lower operating expenses

than a human, it can work 24/7, without generating mistakes.

For attached holders to the harness, tape or cable tie can be used. Regarding tape, Kabatec has its proprietary solution, In case of cable tie, the company Hellermannntyton [4] has an automatic cable tie system. Hellermannntyton has only hand tools, as for automatization automatic cable tie system has to be redesigned.

On the analysed harness soldered connections (cable-PCB) were also present, the solution can be supported by a spectrum of techniques ranging from a not highly advanced like automatic iron soldering, throw laser soldering [132], to point soldering techniques [35]. The last one is developed by Cosmic-Corp from Japan and that is a special solution to efficient soldering cables and THT elements to PCB, process based on single machine and consists of ten phases presented in Fig. 3.7.

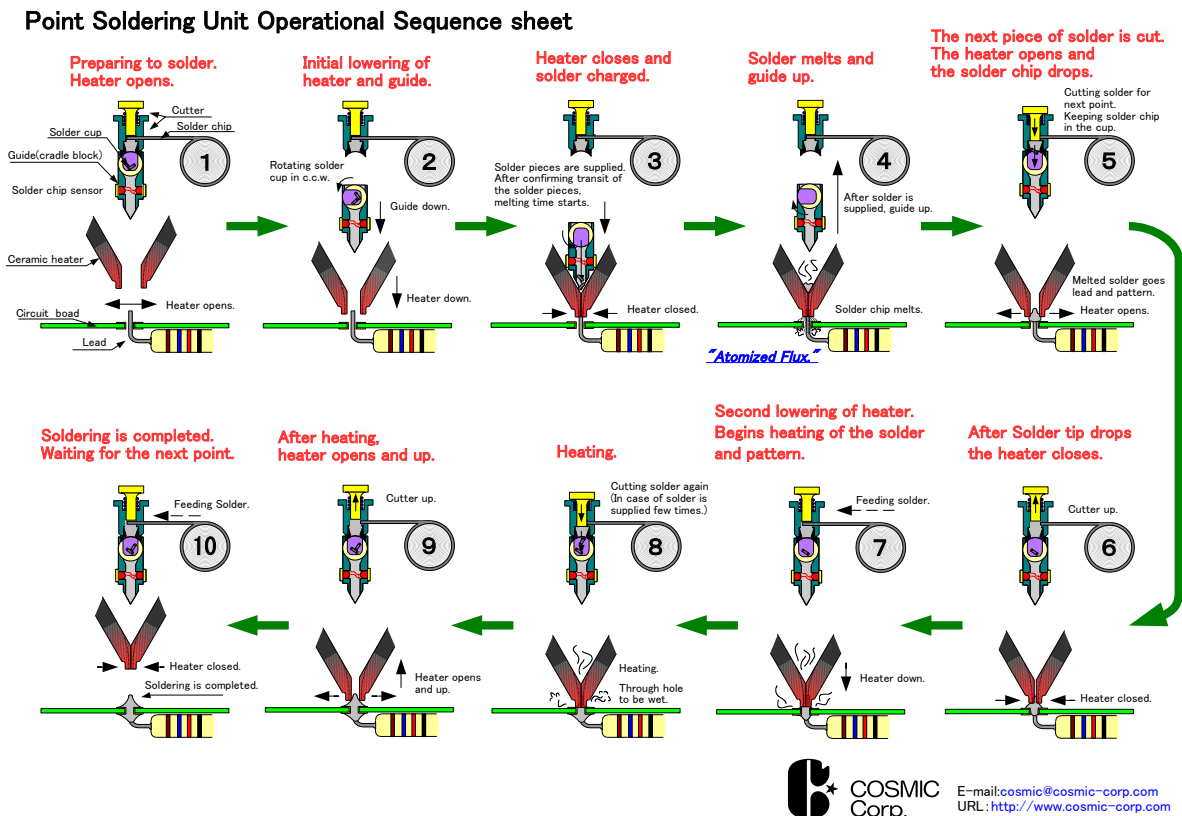

Fig. 3.7. Point Soldering sequence [34]

For fully automatized harness production, almost all technology is available, but only the beginning of the process is sufficiently developed to utilize only stock machines. Before fully automatizing production of single cables (or twisted cables) with terminals, ev-

everything has to be developed. As it was mentioned earlier, the current harness is too complicated. Implementing DLN can have huge impact on the harness complexity. Automotive harness is constantly being simplified in many ways, reducing current on the line (36-48 V systems), more interfaces (e.g. LIN) replacing I/O signals, and others. The advanced manufacturing methods of harness production are growing very fast. Meanwhile, customers needs are increasing even faster, and new systems like AD are being implemented in to the cars. All of the above reasons ultimately increase the number of wires in the car.

It can be concluded that one of the oldest part of an automotive industry - harness, has been continually produced manually for the last 130 years, which is mainly due to the faster development of automotive equipment than the production of a harness.

3.7 Analysis of Automatization of the New Concept

Based on section 3.4 analyses, all options (WC, STD, BC) have great automatization potential. However, there is no machine on the market to produce the harness from the beginning to the end. Two machines from Komax, Sigma 688 ST and Omega, have to work together with industrial robot or other dedicated robot. The only issue is that Komax Omega can insert only a single cable to a connector. It would require modification of Omega machine. The author cannot find any other machine on the market which can insert a pin to connector, and any machine which can insert two cables at the same time. However, in their annual report from 2020 Komax presented the machine Lambda 416 H-MTD for STP cables without any details.

The best way of industrialization is to use standard machines, therefore, the author proposes to use a new solution from Komax Sigma 688 ST [72] where the following applications can be made: cutting, cutting pulled strands, full/half stripping, twisted pair / different, short open wire ends processing, crimping, hot stamp and inkjet marking, split cycle for closed barrels, seal insertion and taping. In 2017 Komax applied for a patent, which was granted in 2020 where Thomas Bussmann in US Patent 10,804,668 B2 [75] described how to insert two cables into a connector housing. To keep aligning with connector holes an additional device is required, US Patent 10,723,584 B2 [76] where Beat Estermann described a method to turn a twisted pair of cables to get perfect aligning, proposed system work with digital camera for optical feedback.

Concluding, all machines are available on the market or have been invented by a key

player of harness industrialization, for further automatization cooperation with Komax can significantly reduce time to develop a final production cell. With reducing time, the cost are usually also reduced.

4. Device Lightweight Network Development

The proposed DLN fulfills all requirements of the employer and has many advantages, which were discussed in the previous chapter. The proof of concept of developed solution allowed to exam its power supply parameters. On the other hand, the communication via DLN between standard elements of the car was also verified. The maximum baud rate was checked in the environment of interference originating from electric motors, heater or lights which were supplied and controlled with the use of DLN. The last functionality which has to be achieved is auto-addressing of DLN modules. This feature of DLN generated most problems, very hard to be solved by typical engineering methods. The chapter is focused on this issue.

4.1 Auto-addressing Methods

There are several methods of auto-addressing. For the beginning, auto-addressing has to be defined. Nowadays, almost every device has its unique number or address. In this thesis, the author focused on addressing defined as assigning the next unique number to the next device installed in DLN. Such a solution is used by Texas Instrument [15], Melexis [90] for LIN interface, as well as RS485 interface [102].

4.1.1 Method Selection

The target of using only one pair of cables, required to deploy a kind of reflectometer idea from optics [117], echo location/ultrasounds [88] and also in detecting damages in electric cables [126] which will be utilized in the proposed approach. However, it has to be simplified to maximum, and the system has to be capable of changing characteristics of the nodes on the line, or has to measure signals by master directly on the clients. Two places of taking measurements are possible.

- Measure on clients: this solution is the easiest one. The author measured up to 400 mV deferments on each node, using a simple pulse generator. The voltage drop was lower on greater distance from the master. The solution required a separate measurement circuit on each node which at the end would give the result, but it would be too expensive to implement.
- Measure on master: the author cannot prove whether this solution will work using an oscilloscope. The voltage drop could be observed using an oscilloscope. However, it was always less than 1 mV. It will be difficult to take measurements by simple ADC circuit. The circuit has to be as simple as possible to reduce potential cost and allow the automotive market to reduce the number of harnesses.

The second approach is the one that was selected taking into account automotive objectives. The author proposed to use computational intelligence techniques connected with the HIL setup to find optimal hardware (structure) and software (parameters) for this functionality. The general concept is that clients will be able to connect coils or/and capacitors to create distortion on the line.

4.1.2 Auto-addressing Configuration

The idea of auto-addressing feature is to generate a special signal by the master board, thereafter generating disruption by client(s), and using parasitic parameters of the cables, recognizing how far the client is from the master. Information about the distance of each client from the master provides a unique address. This method has a disadvantage of minimal cable length between clients. After the first test the author noted that 20 cm of cable was the sufficient length to recognize changes of the signal shape. This is enough to meet the project requirement, and to develop an auto-addressing idea.

4.2 Test Description and Research Stand

The proposed interface of DLN uses only two wires to transmit power, data and allowing auto-addressing, which necessitates a wireless connection to have a second layer of communication between nodes and the MATLAB environment. The second layer is used only for research, to avoid any disturbance from the signal between nodes. It is widely known that many solutions can be incorporated, with optical or radio connection options as are most commonly used.

The optical connection can be characterized by the necessity of face-to-face transceivers' orientation. The idea was to use 15 nodes in the research stand. To ensure high stability, each node should have an individual transceiver, which generates problems to find or build management devices for all 15 transceivers. The second approach is to use radio, which eliminates most of the problems related to optical solutions. The author had to decide which radio communication standard to choose. Due to their broad experience with IoT, the author conducted research on IoT libraries in the MATLAB environment. An external MQTT library written in Java was adapted to the MATLAB environment. After stability tests, the decision was made to continue the approach of using the external library. The test setup was built with MQTT brokers on Raspberry Pi (Rpi), where Raspberry board was also configured as an Access Point (AP) for ESP32 clients.

DLN interface works by continually changing the state of a master module from power delivery to data interface. For the auto-addressing procedure, the signal was divided into a 10 ms period of power delivery, and 12 ms of auto-addressing signals; an example is given in Fig. 4.1a. The positions of clients are known. Calculated positions are compared with known positions, and when they match, parameters such as cost, standard deviation between nodes' addresses (more is better), standard deviation between measures (less is better) and minimal difference between addresses (more is better) are calculated. If not successful, all parameters are set to 1.

Every test contains 15 repeats (for each node — Fig. 4.1a), every repeat contains 25 measure cycles (Fig. 4.1b). Each cycle is based on sending an energy pulse to the line (Fig. 4.2). Most of the parameters were initially programmed to allow change in value during operation. All signals which can have influence on the auto-addressing were connected with algorithm solvers to optimize their value. Schematic 4.2 shows how a generator for inject disturbance was constructed. Variable $X2(A22)$ defines time in μs to charge capacitor C0, higher time needs more energy. Variable p_{h_5} defines which pulse coil will be used to inject the signal. Time to discharge the C0 capacitor (A23) through the coil is constant. Switch s1-s8 is closed during the whole cycle (Fig. 4.1b, elements C0-C24).

Using a dedicated circuit with RC filter, active peak detector and analogue to digital converter (ADC), the microcontroller can capture the numerical value of the response from the line. Based on Andreas Spiess tests [114] the author anticipated that internal ADC from ESP32 microcontroller would not be precise enough to measure signals. The PCB was equipped with external precise ADC, but analogue signal was also connected to integrated ADC from ESP32. During the final test the author recognized that internal ADC was precise enough, and was much cheaper. Therefore, the author decided to use only

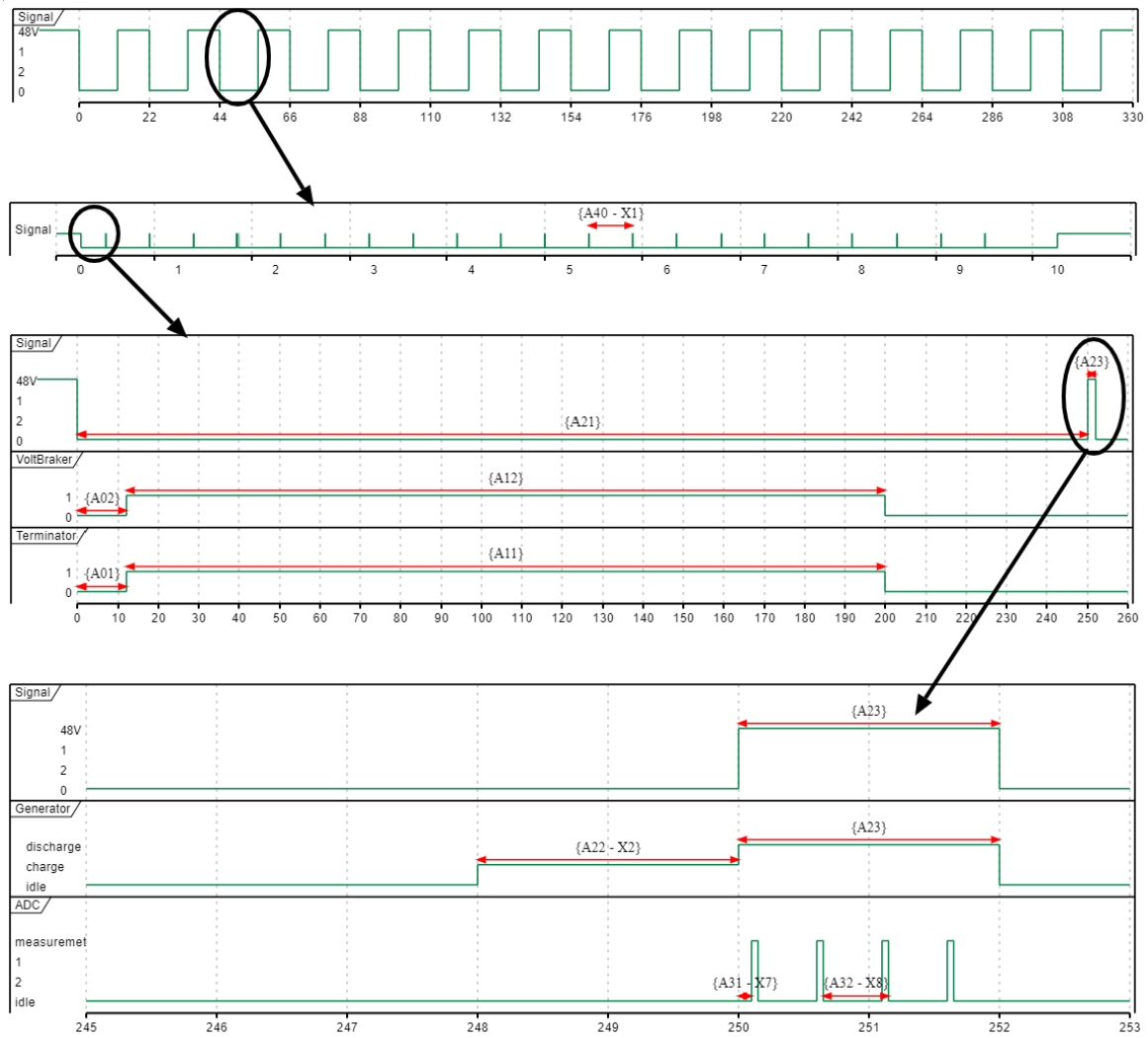

Fig. 4.1. Auto-addressing Signal: a) Standard Signal b) Zoom to Auto-addressing Pulse c) Zoom for Preparation Line to the First Pulse d) Zoom to Pulse Generation and Sampling the Answer on the Line

the internal one. During first tests, using an oscilloscope, the author observed a response from the line. Depending on additional elements on the line, the response signal was characterized by different parameters, like amplitude or length of the wave form. Due to usage of active peak detector, it is essential when the analogue value will be taken. Variable p_{s2} defined the delay between generating pulse and the first ADC sample, Variable p_{s3} defined delay between four measures.

To generate disturbance on the line, a coil, or capacitor, was connected to the line. The schematic in Fig. 4.3 shows the idea of connection. For switches, the author selected transistors with high peak current and fast opening time. To provide many configuration

Tab. 4.1. A List of Decision Variables with Descriptions

Indicator	Range	Description
p_{s1}	1 – 150 [μs]	(Signal A22) — Pulse generator charging time. See Fig. 4.1
p_{h1}	1 – 9	Selection capacitor on Master (see Tab. 4.2).
p_{h2}	1 – 9	Selection coil on Master. See Tab. 4.2
p_{h3}	1 – 9	Selection capacitor on Client. See Tab. 4.2
p_{h4}	1 – 9	Selection coil on Client. See Tab. 4.2
p_{s2}	1 – 999 [μs]	(Signal A31) — delay before first ADC measure. See Fig. 4.1
p_{s3}	1 – 40 [μs]	(Signal A32) — delay between ADC measure. See Fig. 4.1
p_{s4}	1 – 4	Strategy of using coils and capacitors — see Tab. 4.3 and Tab. 4.4
p_{s5}	0 – 7	Method of data analysing 0 — median; 1 — mean; 2 — max; 3 — min; 4 — mode; 5 — sum-max/size; 6 — value of C0 — See Fig. 4.1b; 7 — max-min ;
p_{s6}	0 – 3	Source of data for analysing 0 — S0 — See Fig. 4.1d — ADC 1 — S1 — See Fig. 4.1d — ADC 2 — S2 — See Fig. 4.1d — ADC 3 — S3 — See Fig. 4.1d — ADC
p_{s7}	1 – 4	Define addresses trend 1 — falling trend 2 — rising trend 3 — falling trend + replace last address 4 — rising trend + replace last address
p_{h5}	2 – 8	Coil selection to pulse generator — Master only — Fig. 4.2
p_{h6}	0 – 1	1 — use termination resistor on Master board during measure 0 — do not use
p_{h7}	0 – 1	1 — use termination resistor on Client board during measure 0 — do not use

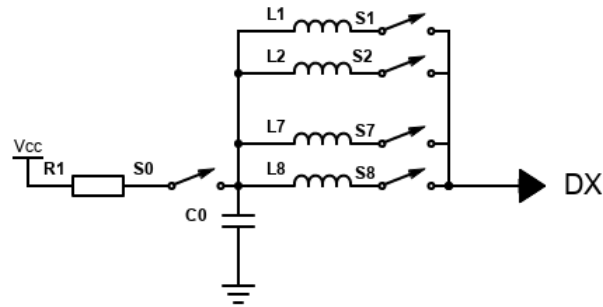

Fig. 4.2. Pulse Generator Schematic

Tab. 4.2. The Components of LC Terminator

	Inductor	Capacitor
1	0 nH	0 pF
2	330 nH	330 pF
3	1 μ H	1 nF
4	3.3 μ H	3.3 nF
5	10 μ H	10 nF
6	33 μ H	33 nF
7	100 μ H	100 nF
8	330 μ H	330 nF
9	1 mH	1 μ F

options, components as shown in Tab. 4.2 were chosen. Later in the research, these components will be named LC terminators.

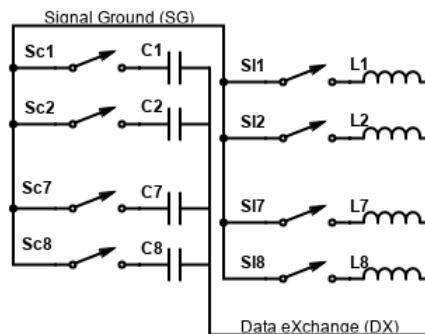

Fig. 4.3. Schematic of LC Terminators

Four auto-addressing strategies have been developed. Algorithms chose a strategy using parameter p_{s_4} [see Tab. 4.1]. Regarding 15 nodes (1 master + 14 clients) measurements

Tab. 4.3. The 1st Auto-addressing Strategy

	Master	Client1	Client2	...	Client n-1	Client n
R0	1	1	1	...	1	1
R1	1	0	1	...	1	1
R2	1	1	0	...	1	1
⋮	⋮	⋮	⋮	⋮	⋮	⋮
R n-1	1	1	1	...	0	1
R n	1	1	1	...	1	0

Tab. 4.4. The 3rd Auto-addressing Strategy

	Master	Client1	Client2	...	Client n-1	Client n
R0	1	0	0	...	0	0
R1	1	1	0	...	0	0
R2	1	1	1	...	0	0
⋮	⋮	⋮	⋮	⋮	⋮	⋮
Rn-1	1	1	1	...	1	0
Rn	1	1	1	...	1	1

had to be repeated 15 times (R0 - R14 in Fig. 4.1a). Strategies define which clients have to connect parallel with the signal line, the LC terminators.

The first strategy is presented in Tab. 4.3. In all variants, LC terminators are always used by the Master board. Parameters p_{h2} and p_{h3} can be set not using LC terminator — it allows us to reduce the quantity of strategy from 8 variants to 4 variants giving the same effect.

The second strategy is similar to the first one, but all LC terminators are disconnected from the line as default, and with every next repeat (R0 - R14) the proper client has to connect its LC terminators.

The third strategy consists of connecting LC terminators of clients with lower positions than current repeat, see example in Tab. 4.4.

The fourth strategy is the last one and it is very similar to the previous one, but at the beginning all LC terminators are connected with the line. The clients disconnect its LC terminators with every iteration.

Parameters p_{h6} and p_{h7} contain information if master (p_{h6}) and client (p_{h7}) should connect termination resistors (100R) to the line.

The first research stand was constructed by using one master and four clients. This

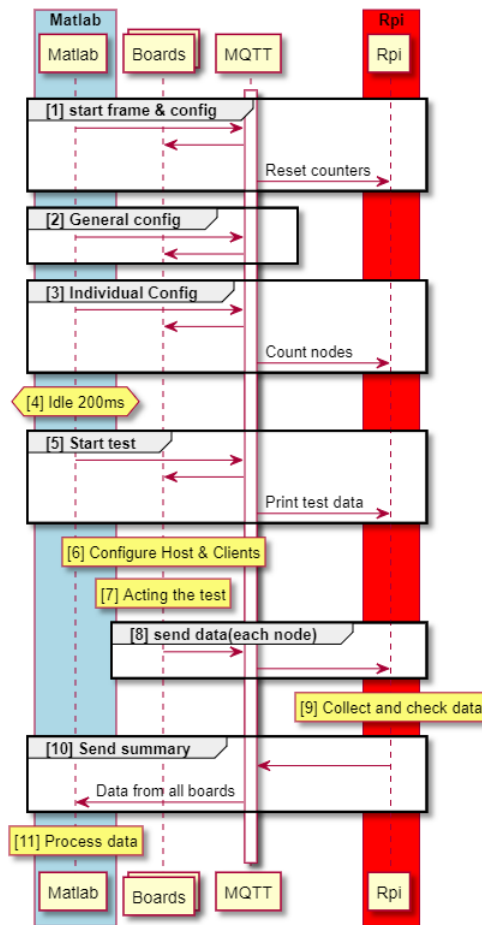

Fig. 4.4. A Data Flow Between Research Stand Modules

application was used to set up many options, like flow of the signals, measured strategies, software on clients and master, objective functions in MATLAB and so forth. After the first tests, specifically changing setup or software on clients was very fast, the author decided to enlarge the research stand. Twenty prototype boards were ordered where each can be configured as master or client, in case of an unpredicted problem, only 15 boards were used to build the HIL setup. Everything worked correctly using Rpi as MQTT server and AP for five boards. With such setup, the author adjusted parameters to optimize communication between nodes. The baud rate with 2 Mbps was achieved. All parameters of communication and power delivering were adjusted using well-known laboratory equipment and engineering knowledge.

The next step was to extend the research stand to 15 boards and find parameters to auto-addressing, which finally was more challenging than the author expected. The stability of AP on Rpi was unsatisfactory when all 15 nodes sent the report after the test

(exactly at the same moment). Each board sent 100 reports with measured parameters, which gave 1500 reports from the whole HIL. The behaviour was diagnosed by external tool - MQTT.fx. It necessitated the use of additional AP, where Mikrotik RouterBoard was selected. After rebuilding the research stand, all frames could be received by the computer with MQTT.fx and MATLAB environment installed on it. The author had to tackle with the last issue: the MQTT library was written in Java, which decreased speed to process all frames from MQTT in MATLAB environment. The standard solution in MQTT frames is to increase quality of service (QoS). The disadvantage of such a solution is that the sending time of each measurement is extended. Therefore, in the case of planned 0.5 - 1 million tests, another solution was selected. A two-thread script, written in python, was running on Rpi. The first thread handled receiving and decoding JSON frames from MQTT, the second one analysed data, and after the test was finished, collect all data to one frame which was then sent to MATLAB environment. Such configuration made the research stand and data flow concept more complicated. However, this could significantly reduce the time of a single measurement, and guaranteed data correctness up to 100%. The only programmed delay (Fig. 4.4 - [4]) was to synchronize all nodes.

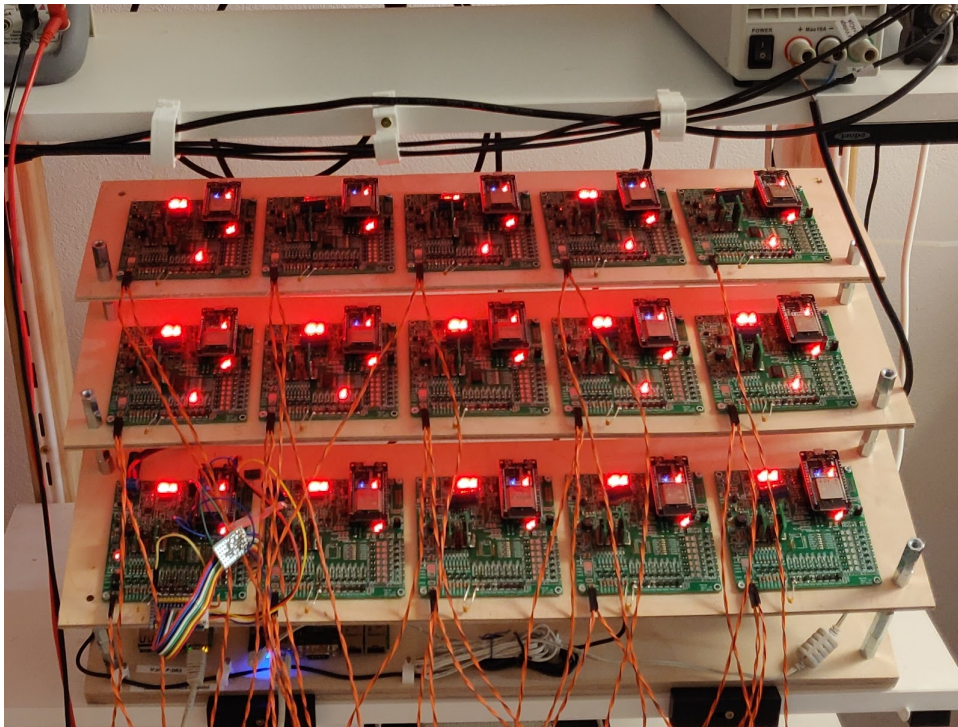

Fig. 4.5. Research Stand Consisting of Master and Clients in HIL Configuration

The author prepared a special program in MATLAB environment which received the input data: 15 variables, where different optimization algorithms trying to find optimal

values of decision variables such as strictly hardware dependent parameters, or components cost of LC terminators. The communication between all components of the stand is shown in Fig. 4.4. The MATLAB environment code is responsible for building up MQTT frames. All frames are sent to boards and Rpi. Client boards, after receiving frames with individual configuration (Fig. 4.4 - frame 3), are set to wait for a trigger from the master. To avoid any problem with synchronization, the software waits 200 ms (Fig. 4.4 - [4]) before the data publish start of test frame (Fig. 4.4 - frame 5). After the test, the boards publish measured data which is collected by Rpi to one complex frame (Fig. 4.4 - frame 9), that is published by Rpi, and subscribed by the MATLAB environment (Fig. 4.4 - frame 10).

The main goal of the research stand is to optimize communication between nodes, test the setup, and optimize auto-addressing parameters. This chapter is dedicated to the second use case, that means to optimize auto-addressing parameters. Fig. 4.5 shows relations and signals flow between blocks in the whole HIL system. Fig. 4.4 and Fig. 4.7 show test bench and nodes of the communication. One master can be found in the bottom-right corner and fourteen client nodes. Each node is connected through single twisted pair of cables, and WLAN to allow us reliable communication during all tests.

4.3 HIL-based Optimization Method for Bus Prototyping

The effectiveness of the power supply and communication bus strongly depends on its structure \mathcal{S} as well as hardware components and software parameters of the proposed solution. These factors have a great influence on addressable, and therefore they must be adjusted correctly. The main purpose of the optimization process is to search for the optimal structure of the bus and the optimal values of hardware parameters \mathbf{p}_h and software parameters \mathbf{p}_s , in order to obtain the highest performance of the whole system. This issue is viewed as a multi-objective optimization problem and hence it can be stated as the following equation:

$$\begin{aligned} \text{Minimize } & \mathbf{C}(\mathcal{S}, \mathbf{p}_h, \mathbf{p}_s) = \left[c_1(\mathcal{S}, \mathbf{p}_h, \mathbf{p}_s) \ c_2(\mathcal{S}, \mathbf{p}_h, \mathbf{p}_s) \ \dots \ c_n(\mathcal{S}, \mathbf{p}_h, \mathbf{p}_s) \right] \\ \text{subject to } & \Omega(\mathcal{S}, \mathbf{p}_h, \mathbf{p}_s, \mathbf{C}), \end{aligned} \quad (4.1)$$

where \mathcal{S} is the structure of DLN nodes, \mathbf{p}_h and \mathbf{p}_s represent decision variables, c_i is the i -th criterion function, Ω is related to constraints and boundaries which should be chosen

to consider different variants of hardware and software parameters. To reduce the complexity of the problem, it is noted that in some cases the structure \mathcal{S} can be determined using a part of decision variables corresponding to values of hardware features included in \mathbf{p}_h .

The hardware and software features of the bus for the given number of the modules n can be written using the general formula as follows:

$$\mathbf{p} = [\mathbf{p}_{h_M} \ \mathbf{p}_{h_C} \ \mathbf{p}_{s_M} \ \mathbf{p}_{s_C}], \quad (4.2)$$

where \mathbf{p}_{h_M} and \mathbf{p}_{h_C} denote hardware parameters of a master and clients, whereas \mathbf{p}_{s_M} and \mathbf{p}_{s_C} describe their software parameters.

In this thesis, it is assumed that \mathbf{p}_{h_M} is composed of seven values of parameters as follows:

$$\mathbf{p}_{h_M} = [p_{h_1}, p_{h_2}, p_{h_6}, p_{h_5}], \quad (4.3)$$

and \mathbf{p}_{h_C} is composed of other parameters in the following way:

$$\mathbf{p}_{h_C} = [p_{h_3}, p_{h_4}, p_{h_7}], \quad (4.4)$$

where p_{h_2} is the number corresponding to the selected capacitor on master (see Tab. 4.2), p_{h_2} is the number corresponding to the selected inductor on master (see Tab. 4.2), p_{h_6} is used to decide whether a termination resistor on master is necessary or not, p_{h_5} is applied to describe the inductor in pulse generator (see Fig. 4.2), p_{h_3} is used to select a capacitor on client (see Tab. 4.2) and (Fig. 4.3), p_{h_4} is used to select an inductor on client (see Tab. 4.2 and Fig. 4.3), p_{h_7} is used to decide whether a termination resistor on the client is needed or not.

Except for hardware parameters, software decision variables can be divided to auto-addressing configuration like p_{s_2} and p_{s_3} where, respectively, delay before first ADC sample, and gap between samples can be chosen, p_{s_1} is the time to charge pulse generator (A22 in Fig. 4.1d), and p_{s_4} which is the discrete variable defining strategy of auto-

addressing, especially how to manage using coils and capacitors on master and clients (Tab. 4.3, and Tab. 4.4).

The second group of software decision variable are data process methods, such as p_{s_5} where mathematical operations of input data are chosen, p_{s_6} where source of data for analysing is chosen, and p_{s_7} where target manner of addressing is chosen.

The prior research has thoroughly investigated how following addresses will look like, two obvious trends were noticed — following addresses will rise or fall, as well as another two not so obvious — in rising trend the lower value is the last one, and in falling trend, the higher is the last one. An example is shown in Fig. 4.6.

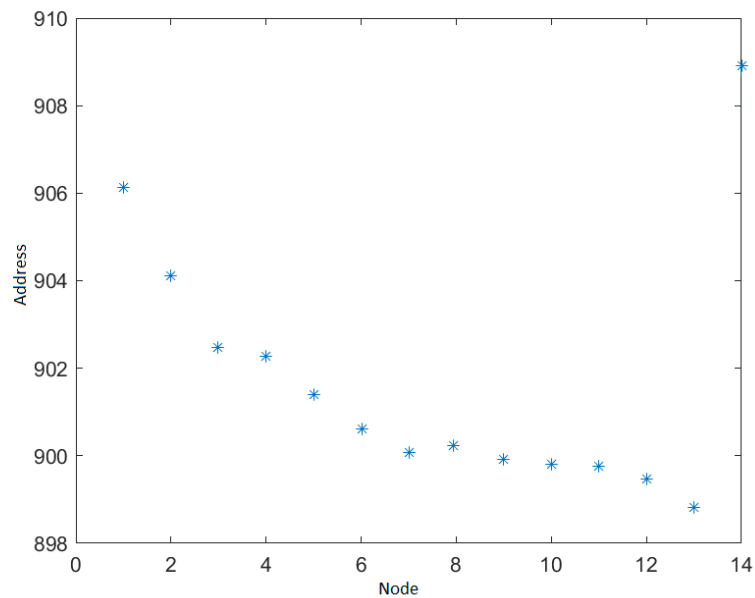

Fig. 4.6. One of the Characteristic Trends of Addresses Value

Generally, multi-objective functions very often have an infinite number of local as well as global extrema and therefore one should investigate a set of points, each of which satisfies the objectives. Because of this, the predominant Pareto optimality concept is adopted. The Pareto-optimal solution is often considered the same as a non-dominated solution. It exists if there is no solution that improves at least one objective function without worsening others. In this thesis, it is sufficient to apply the following fundamental measures as objectives, that are:

- c_1 which is based on addressable factor:

$$c_1(\mathbf{p}_h, \mathbf{p}_s) = \begin{cases} \frac{1}{\sum_{i=2}^{n-1} \begin{pmatrix} 1 & \text{if } a_i > a_{i+1} \\ 0 & \text{other} \end{pmatrix}} & \text{if } p_{s_7} = 2 \text{ or } 4 \\ \frac{1}{\sum_{i=2}^{n-1} \begin{pmatrix} 1 & \text{if } a_i < a_{i+1} \\ 0 & \text{other} \end{pmatrix}} & \text{other} \end{cases}, \quad (4.5)$$

where elements of the vector \mathbf{a} are computed using the proposed rule in the form as follows:

$$a_n(\mathbf{a}) = \begin{cases} a_n = \max(\mathbf{a}) + 1 & \text{if } a_n = \min(\mathbf{a}) \text{ and } p_{s_7} = 3 \\ a_n = \min(\mathbf{a}) - 1 & \text{if } a_n = \max(\mathbf{a}) \text{ and } p_{s_7} = 4 \\ \text{no change in other} & \end{cases}, \quad (4.6)$$

and n represents the number of nodes, p_{s_7} defines the addresses trend (see Tab. 4.1), a_i measures address value of the i -th node.

- c_2 is based on the minimal difference between addresses:

$$c_2(\mathbf{p}_h, \mathbf{p}_s) = \frac{1}{\Delta_{max} + 1}, \quad (4.7)$$

where Δ_{max} describes difference in addresses between neighbour nodes.

- c_3 is used to show the overall cost of the system:

$$c_3(\mathbf{p}_h) = v(\mathbf{p}_{h_M}, \mathbf{p}_{h_C}, n), \quad (4.8)$$

where v is the function which calculates a total market cost for the given DLN configuration used in the current approach.

On the other hand, the global criterion method can be successfully applied to transform a multiple objective function into a single objective one. This way, an indirect utility function can be expressed in its simplest form as the weighted sum of objectives:

$$C(\mathbf{p}_h, \mathbf{p}_s) = \frac{\mathbf{w}\mathbf{C}^T(\mathbf{p})}{\mathbf{1}\mathbf{w}^T} = \begin{pmatrix} 5c_1 & \text{if } c_1 \geq \frac{1}{n} - 1 \\ w_1c_2 + w_2c_3 & \text{other} \end{pmatrix}, \quad (4.9)$$

where \mathbf{w} is a row vector with weights indicating the relative significance of the objective functions, in this study, w_1 and w_2 indicate the weights for the second and third criteria, respectively.

The optimal solution is found if the criterion function \mathbf{C} has a relative minimum value at \mathbf{p}^* that means if

$$\mathbf{p}^* = [\mathbf{p}_h^* \ \mathbf{p}_s^*] = \underbrace{\operatorname{argmin}_{\mathbf{p} \in \Omega} \mathbf{C}(\mathbf{p}_h, \mathbf{p}_s)}_{\mathbf{p} \in \Omega}. \quad (4.10)$$

It was decided to apply intelligent computing and hardware-in-the-loop techniques due to several difficulties in bus prototyping discussed in the previous section. The proposed scheme of the optimization method is presented in Fig. 4.7.

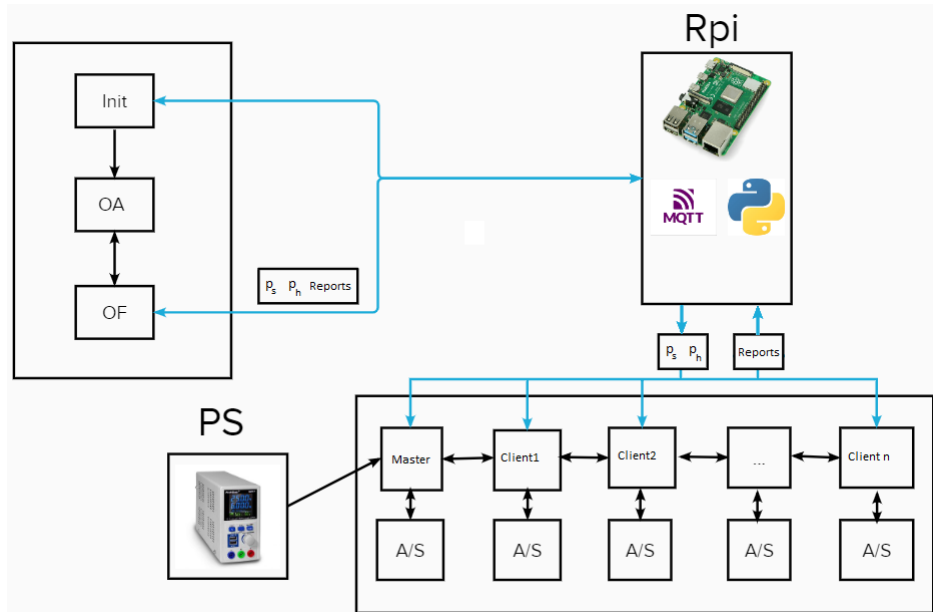

Fig. 4.7. General Scheme of the Proposed Method

The HIL part is composed of n modules ($n - 1$ clients and one master) where all modules are connected with one twisted pair of cables (black connections between modules on Fig. 4.7), and wireless network to remove influence on auto-addressing signals (blue

connections). Rpi is a hardware platform with MQTT broker and Python script. The software and timing relations in this HIL system are described in Fig 4.4.

The optimization process is managed by the software created employing MATLAB environment and Raspberry Pi platform. The author decided to use computational intelligence algorithms such as genetic and particle swarm algorithms implemented in the MATLAB environment with the Global Optimization Toolbox.

Different optimization algorithms can be utilized for solving the problem, which has been declared in the form of (4.1) or (4.9). Hard computing optimization methods e.g. gradient-based approaches cannot be adopted in this thesis, mainly due to the stochastic nature of the objectives because there are continuous and discrete decision variables in the vector \mathbf{p} .

In purely stochastic optimization methods, like Monte Carlo techniques will not be able to find an optimal solution in this case guaranteeing polynomial-time convergence. To find the global minimum of the function, soft computing optimization methods may be used. In this thesis, heuristic algorithms are applied, such as single or multi-objective genetic algorithm and particle swarm optimization algorithm.

4.4 Selected Optimization Techniques

Nowadays, many phenomena and processes take place largely at random. Sometimes the course of a given process depends on so many parameters burdened with variability, that for simplification one can assume that it occurs at complete random. In order to facilitate observation and analysis of such processes, simulation techniques and methods have been developed, attempting to describe a given phenomenon using the probability [111].

Simulation methods are widely used in many engineering disciplines, where they cover the area of design associated with tests of numerical studies performed on discrete realizations of random design variables in engineering design. They are also used where the problem is too complex (calculations of integrals or chains of statistical processes are difficult to describe mathematically) so that its results can be predicted using an analytical approach.

For many years, numerical methods have been dismissed due to lack of computational tools capable of handling the complexity of the data generation process, and the

required population size of execution sets could not be written within the parameters of available computer hardware. However, with the increasing capabilities of computers in performing fast, even complex engineering designs, the rejection of numerical techniques found in the literature in previous decades became obsolete, and these methods, appropriately developed and modified, became popular in the analysis of almost any structure [84].

Nowadays, the simulation approach is already widespread. Currently, it has become a basic technique of calculating a specific group of engineering problems. This is mainly due to advantages of the approach, relatively simple mathematical description (related to other methods of theory of safety estimation) and easy implementation into computer-aided design tools. It is also valued for the ease of processing the results, simplicity of the sensitivity analysis performed through this approach and versatility of future numerical experiments that can be undertaken thanks to the technique in the subject of the analysed problem [82].

Disadvantages of the simulation approach are its time-consuming computation, small control over the generation product for complex engineering structures, and the difficulty of simulation approach, approach to be used as a tool for the design of a complex engineering structures. It should also be noted that in solving engineering issues, problems arise in defining probability distributions of arbitrary events in such a way that they properly reflect the nature of the described variability of construction parameters. It is also difficult to determine the values of probabilistic moments of used random variables, the methodology of variable generation itself is also difficult.

4.4.1 Latin Hypercube Sampling

Latin hypercube sampling is an extension of the idea behind weighted sampling. The method was developed by M. D. McKay [89] and it was used in this thesis, where randomly distributed and randomly permuted values of decision variables were used. This type of sampling is one of the most efficient method for generating random samples that can be obtained from the density function of the probability distribution function of n -dimensional random vector. This method is now widely used in reliability analysis of engineering structures, in scientific and engineering investigation.

In the LHS technique, the space of random variables Rv tasks is also divided into several disjoint subspaces $Rv(l = 1; 2; 3; 4; L)$ however, there is some restriction on the gener-

ation of samples from given subspaces.

In stratified sampling, during a single generation, from each proposed by the designer l -th subinterval defined for a single i -th dimension of the random variables vector \mathbf{p}_i a certain number of samples is generated in such a way the reciprocity of relations between all n dimensions is preserved, and the generated samples contain random realizations of all other dimensions of the vector \mathbf{P} .

On the other hand, LHS in a single generation, only one sample is generated from each l -th subinterval defined for a single i -th dimension of a component in a vector of random variables, created on a combinatorial basis between all n dimensions of the vector \mathbf{P} [89].

Such an operation can be illustrated by the similarity to the so-called Latin square or Euler square, which is a l -level, two-dimensional numerical array filled with L of different values (in Euler's original formulation these were letters of the Latin alphabet, this is where the name of the technique comes from), in such a way that in a given i -th row and the i -th column of elements appears only in one place (the intersection of the column and the row). There are finitely many possibilities of creating a Latin square, but the number (indirectly depending on the dimension l of the subdivision of the number array) is satisfyingly large, to be annexed as the number of generated samples for simulation methods.

The Euler Latin hypercube is a generalization of the concept of the Latin square to an arbitrary number of dimensions (in general, to n dimensions of the space of realizations of a vector of random variables \mathbf{P}). To take a random sample from a function of a n -dimensional random variable, the range of variation of each dimension of the realization of the random variable is split into l equally likely to occur sub-compartments, from which only one sample is generated, lying on each edge of the intersection of subdivisions Rv_l of each of the n dimensions. The drawn samples can be taken from a single point of intersection of edges only once, keeping in mind, however, that the combinations of distribution of points of realization of random variables on the intersection edges are many [56, 57].

The maximum number of combinations (and thus the maximum possible number of samples) for sampling the Latin hypercube of n -dimensional space of random variables Rv , each has been divided into l equally probable subdivisions, can be calculated as in Eq. 4.11.

$$L_p = \left(\prod_{j=0}^{l-1} (l-j) \right)^{n-1} = (l!)^{n-1}. \quad (4.11)$$

Samples on a given subdivision Ω_l of each of the n dimensions are most commonly selected using the inverse of the probability distribution of a single component vector of a random variable (P_i) in the manner defined by the Eq. 4.12.

$$p_{i_k} = F_i^{-1} \left(\frac{k-0.5}{L} \right), \quad (4.12)$$

where p_{i_k} is the k -th sample of the i -th component of the random variable, $F_i^{-1}()$ is the inverse of the distribution of its probability distribution, and L is the maximum number of samples that can be obtained on a single dimension of the n -dimensional execution space $R\nu$.

4.4.2 Single or Multi-objective Genetic Algorithm

Genetic Algorithms (GA) are based on the natural selection process that mimics biological evolution launched by Charles Darwin book "On the Origin of Species" published in 1859 [38]. This theory is a source to follow in solving problems in various fields of science. It should be emphasized that the mechanisms of evolution (e.g. selection, crossing, mutation and reproduction) are the basis of genetic algorithms.

To apply such an optimization technique for finding a solution of the problem, it is necessary to define the following properties of the algorithm [40]: the representation of the individuals, the fitness function, crossover and mutation operators, selection and succession methods. GA are techniques for searching the solution space, developed over several decades. The most popular of them are: simple genetic algorithm developed by John Holland [54] in the United States of America and popularized by David Goldberg [49], and many other scientists.

To talk about genetic algorithms, the terminology from genetics must be discussed. These terms include the chromosome, which is a sequence of ordered elementary units called genes. The set of chromosomes is the genotype, while its uncoded counterpart is the phenotype. The value of a gene is simply an allele, and its location on the chromo-

some is the locus. The space in which the algorithm operates is called the population and consists of individuals whose traits are specified by being recorded as a genotype. In order for everything to be consistent with the theory of evolution, an element is still needed to determine the degree of adaptation of individuals, which in a further stage will allow the survival of the better adapted and thus eliminate the weaker individuals. Successive generations of individuals are created through selection, cross-breeding and mutation.

The task of a GA is to model a process by mimicking the natural course of evolution. The whole process can be represented in a simplified way by a flowchart in Fig. 4.8. A base population, often called the initial population or parental population. This population is generated randomly. The next step is to evaluate the adaptation of the parental individuals. Next, the retention condition is checked. When the retention condition is not met, the so-called selection is made and choice of individuals for reproduction. This means that not all individuals in the population have the same chance to participate in reproduction. Individuals for whom the fitness function is characterized by the lower values have higher probability to "move on to the next stage" of evolution. At this stage, crossover and mutation occur. Then the adaptations of the new generation (generations), created in the processes of mutation and crossover, are evaluated.

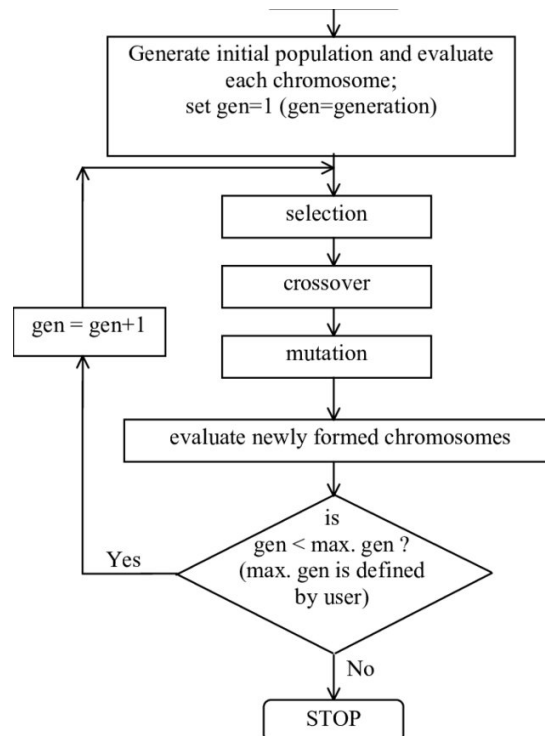

Fig. 4.8. Genetic Algorithm Workflow [18]

Issues can arise right from the start - for example, with the way individuals are encoded. The most popular is the binary code. The only thing to remember is to determine the sufficient number of bits with which the There are two rules for choosing the right code. These rules are given by D. Goldberg [49].

During design, you must also determine the function of the adaptation that will allow, as it happens in the environment of living organisms, the survival of stronger and better adapted individuals while eliminating inferior solutions.

To create a new and better population, genetic operations are performed on individuals selected from the "parent" population. This selection can be made using several methods [49, 50, 137]:

- roulette,
- deterministic sampling,
- stochastic by residuals with repetition,
- stochastic by residuals without repetition,
- tournament,
- ranked.

The roulette method is most often used in practice and consists in creating a roulette wheel from the summed values of adaptation functions of individual solutions. Individuals, which are assigned a slice of the wheel proportional to their value of the adaptation function, are drawn to the next population according to the rules of the game of roulette.

The next three methods involve calculating the expected number of descendants for each individual. These three methods differ in the way of selecting the individuals that will complete the new population. This is done to preserve population size in subsequent cycles. In the tournament method, selected individuals "compete" with each other, and the better of the two goes on to the next population. On the other hand, in the ranking method the number of descendants depends on the rank of an individual. Selected individuals are subjected to operations of crossover and mutation. During crossover, fragments of genotypes are exchanged between two individuals. Depending on the number of genotype crossing over sites, which is the way of the genotype into parts, crossover is divided into single-point and multi-point. Mutation, on the other hand, involves exchanging the value of a bit from 0 to 1 or vice versa.

The genetic operations are followed by a return to assess the adaptation of a new generation of individuals and checking the stopping condition. Determining the stopping condition of an algorithm causes many difficulties, so special criteria have been developed. The most commonly used criteria comprise the criterion of a satisfactory level of the adaptation function of the minimum rate of improvement. In the first of them the algorithm stops when the value of the adaptation function set by the designer is reached, while in the second the algorithm stops when in the number of generations specified by the designer the solution does not improve and also a value specified by the designer. It is necessary to mention here a basic theorem in the theory of genetic algorithms, namely, the Schema Theorem. It states that narrow schemes, low-order, and well adapted in successive generations have a tendency to spread exponentially. It becomes necessary, here to give a definition of schema. A schema is nothing but a set of chromosomes in which the values of individual genes are the same as the values of the similarity pattern genes at particular positions.

A schema row is the number of ones and zeros in the schema, i.e. the number of genes with a value different from the sign, which may contain either 0 or 1. The span of the schema, on the other hand, is the difference between the extreme positions of the pattern different from, that is, the positions of genes containing 0 or 1.

From the Schema Theorem comes the so-called brick hypothesis. It states that genetic algorithms work by relying on the assembly of strings of genes called bricks. What is important is that the genes in the chromosomes are arranged. It is essential that the genes in the chromosomes are arranged in such a way that those close to each other are interdependent. Groups of genes transfer information among one another.

Genetic algorithms can be used to solve the transportation problems, furthermore, in automation, mechanics and electronics and control. There is a well-known use case of genetic algorithms in flexible manufacturing systems, especially for operational control [120]. A case of using genetic algorithms in structural mechanics is described in [130]. There are also attempts to apply genetic algorithm to the design of hydraulic systems. One can also encounter the application of genetic algorithms for task scheduling and resource allocation in computer networks and systems, as well as in production systems [59, 60]. Genetic algorithms can also be used for problems related to economic departments.

In this thesis, it is assumed, that the number of individuals in the population is fixed at each epoch of the genetic process and that individuals are composed of genes representing real numeric and integer values of adjustable hardware and software parameters of

the bus. The length of the chromosome is dependent on the number of these parameters and equals the length of the vector \mathbf{p} :

$$\mathbf{chr} = \mathbf{p} = [p_1 \ p_2 \ \dots \ p_d]. \quad (4.13)$$

The initial population is generated using the normal distribution. The fitness value of an individual is computed using the objective function (4.1) or (4.9). The best fitness value means the smallest value for every individual in the population. Stochastic uniform is applied to choose parents for the next generation, whereas succession operations are realized by defining the reproduction rules characterized by two parameters: elite count (δ_s) and crossover fraction (p_c). The first parameter describes the number of individuals characterized with the best fitness values in the current generation, which will survive to next generation. The second parameter describes the fraction of individuals in the next generation, created by crossover, other than elite children.

The author decided to use a heuristic crossover operator. Based on two individuals \mathbf{p}_1 and \mathbf{p}_2 , in the case if $C(\mathbf{p}_1) < C(\mathbf{p}_2)$, then the new one \mathbf{p}_3 is created according to the formula mentioned below

$$\mathbf{p}_3 = \mathbf{p}_2 + \lambda_h (\mathbf{p}_1 - \mathbf{p}_2), \quad (4.14)$$

where λ_h is a fraction pointing at the better adapted individual.

A mutation operator is in charge of generating heterogeneous individuals. This adaptive feasible method operator is randomly generating directions regarding the last successful or unsuccessful generation. The direction and step length satisfying bounds and linear constraints is found by mutation operator finds. The algorithm is also described with two parameters, the population size and the number of generations. The values of mentioned parameters are randomly selected during optimization experiments. In this study, it is decided that the total number of evaluation of the fitness function is constant, and it is equal to Ψ . Hence, the number of individuals in population is calculated using the following formula:

$$\text{Population} = \frac{\Psi}{\text{Generations}}. \quad (4.15)$$

In the thesis, the variant of the multi-objective genetic algorithm proposed by K. Deb is applied [39]. The algorithm is implemented in the MATLAB environment and it uses a controlled elitist genetic algorithm named NSGA-II. In this approach, the first number of population is automatically generated. The next generation is calculated using the uncontrolled rate and the range of human population in the current generation. Elitist GA always favours people with a better fitness level (rank), a controlled elitist GA also favours individuals which can help increase population diversity even if they have low fitness values. It is critical to keep the diversity of the population so that algorithm can come together to the right place of Pareto. This is done by controlling senior members of the community as the algorithm progresses. The Pareto fraction option limits the number of individuals in front of Pareto (special members) and distance work helps to maintain diversity in advance by selecting people further away.

4.4.3 Particle Swarm Optimization

The particle swarm optimization is a population-based stochastic optimization technique [67], which is inspired by simulation of the social behaviour reflected in flocks of birds, bees and fish that adapt their movements to seek the best food sources as well as to avoid predators, living in a particular territory, bound together by a more or less advanced form of social organization. The joining of individuals into flocks is most often connected with reproduction or searching for food. The Particle Swarm Optimization (PSO) algorithm was proposed in 1995 by Kennedy and Eberhart [67]. The idea of the algorithm comes from mimicking the behaviour of populations of living things - birds ants, bees, skylights, bats, cockroaches, krill, etc.) in which a single individual has very limited ability to make decisions and communicate with each other, the population as a whole, despite the lack of a central control system, exhibits the characteristics of having intelligence, that is, reacting to changes in the environment and collectively acting. A numerical model of the behaviour of a group of objects treats the population as a swarm, and each individual as a particle. This type of optimization approach is also viewed as a parallel genetic computation technique.

As the steps proceed, the particles move to new positions, simulating adoption of the

swarm into the environment, i.e., they search for the optimum. The algorithm searches for the extreme value of the adaptation function as a control objective function. A population of moving particles can remember in the search space the point with the best value of the objective function and can transmit this information to all or part population. Based on the set of information thus obtained, the individual particles can change their position in order to reach the point with the best properties.

The features of a swarm of particles can be represented by the following properties:

- stability - the ability to create behaviour with a moderate response to changes in environment,
- adaptation - the ability to change behaviour if forced by the environment,
- proximity - the ability to calculate time and distance,
- quality - the ability to evaluate interactions with the environment.

Numerically, the basic PSO algorithm is formulated in this thesis in vector notation, such as it is proposed in [124]. The velocity \mathbf{v}_k is updated using its current value and a term which attracts the particle towards its own previous best position \mathbf{p}_1^* and globally the best position \mathbf{p}_2^* in the whole swarm:

$$\mathbf{v}_{k+1} = a\mathbf{v}_k + b_1\mathbf{r}_1 \otimes (\mathbf{p}_1^* - \mathbf{p}_k) + b_2\mathbf{r}_2 \otimes (\mathbf{p}_2^* - \mathbf{p}_k), \quad (4.16)$$

while, the particle position \mathbf{p}_k is dynamically actualized using its current value and the newly computed velocity \mathbf{v}_{k+1} :

$$\mathbf{p}_{k+1} = c\mathbf{p}_k + d\mathbf{v}_{k+1}, \quad (4.17)$$

where the symbol \otimes denotes element-by-element vector multiplication, a is the momentum factor also known as the inertia weight, coefficients b_1 and b_2 are used to describe the strength of attraction (cognitive and social attraction coefficients, respectively), c and d are black-box tuning parameters, vectors of random numbers \mathbf{r}_1 and \mathbf{r}_2 that are randomness useful for good state space exploration (they are usually obtained using the generator of pseudo-random numbers with uniform distribution on the range of 0 to 1).

In this algorithm, the cost function in the form of Eq. 4.9 was used. The PSO algorithm characterizes three main parameters - population size, self-adjustment weight and minimal neighbours' fraction. To compare reliable between algorithms, the same total number of function evaluation is necessary (Ψ). Hence, the max iteration is calculated using the simple equation:

$$\text{SwarmSize} = \left\lceil \frac{\Psi}{\text{MaxIter} + 1} \right\rceil. \quad (4.18)$$

The self-adjustment weight parameter can be in a range from 0.5 to 3.5 with step 1.0, where a default value is 1.49. Considering the stability analysis provided by Brest et al. [24], Clerc and Kennedy [29] or Katunin and Przysłałka [65], it is decided to relate the self-adjustment weight (b_1) and social adjustment weight (b_2) as follows:

$$b_2 = 4.05 - b_1. \quad (4.19)$$

The above technique was selected to test the parameters of the algorithm with different configurations. A group of researchers uses PSO with fixed parameters, where self-adjustment weight (b_1) and social adjustment weight (b_2) are set to 2 [112, 139]. The adopted methodology used closest values at $b_1 = 2.5$ and at $b_1 = 2.5$, where b_2 is calculated to 1.55 and 2.55. Interpolating results from Chapter 5, the authors conclude that the decision was the right one. The interpolated quality parameters of PSO suggest that the default value of b_1 is closer to optimal than $b_2 = 2$.

5. Verification and Validation Studies

The verification studies were illustrated by dividing into several sections, starting from LHS, GA and PSO, and finalizing with additional measures by means of the optimal configuration of algorithms. Solution finding process is frequently flawed with the risk of not finding the best-fit result, especially in a very noisy environment. The author decided to start out with the LHS algorithm to have sample coverage, and to juxtapose results with heuristic algorithms. The results would be beneficial for comparison with other algorithms, to test if heuristic optimization algorithms can guarantee the answer, which is enough from practical perspective. The chapter presents quantitative and qualitative comparison for both types of heuristic algorithms. One of the foremost important measures to rate auto-addressing parameters is c_1 (Eq. 4.5), which may be a conditional measure. The result determines whether or not the configuration will be used.

The validation study was carried out in order to show industrialization potential of DLN according to the automotive industry standards. Due to the implementation nature of this thesis, the best research results were checked taking into account the stability issue during operational work of DLN. The suitability of the proposed interface with auto-addressing functionality is also discussed.

5.1 Optimization Results Obtained Using LHS

The author generated $\Psi = 10000$ unique elements using LHS and ran simulations by means of HIL to obtain the result. Only seven configurations of auto-addressing which were selected by LHS delivered correct addressing. The quantity of tests such as a success rate was calculated. LHS algorithm delivered the success factor at the extent 0.07%. It can be used to prove that heuristic algorithms such as GA and PSO should be accustomed to find the better configuration of auto-addressing or/and with smaller number of computations.

To have reliable addressing, c_2 should be at minimum level of 0.5. LHS algorithm gives only three such results, which is 0.03% of all outcomes. LHS algorithm does not deliver

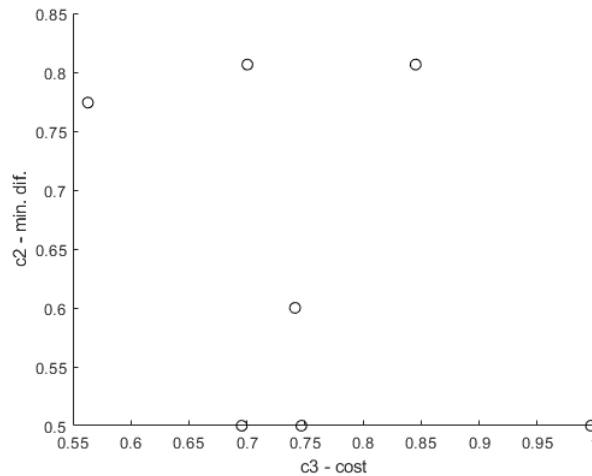

Fig. 5.1. The Visualisation of Optimization Results Obtained Using LHS

any information which decision variable (\mathbf{p}) can be reduced, as it can find many values of parameters for each decision variable in all seven results. The author intended to analyse the relation between decision variable, however because of only three valuable results, it was not possible.

5.2 Optimization Results Obtained Using MOGA

The results of multi-objective optimization using the genetic algorithm are divided into two parts. The first approach is applied for quantity analysis, where the author assessed how many proper results were obtained in each configuration of the algorithm. The second one is the qualitative comparison, where the author checked how close the solutions were to the optimum.

5.2.1 Quantitative Analysis of MOGA Results

The author carried out 48 optimization trials with different parameters (Tab. 4.1). The best configurations found 50 results in 100 individuals (the crossover fraction set to 0.4 and the crossover heuristic parameter set to 1.2), which in correlation to LSH was remarkable. The worst one could not find any result - all cases with 200 generations (the population was characterized by only 50 individuals). Fig. 5.2 and Tab. 5.1 present a number of correct solutions, depending on values of algorithm parameters. The quantity of correct results is represented by the size of the bubble.

Tab. 5.1. The Sum of Correct Results Using Proposed Values of MOGA Parameters (Colour Code: green → the best; Light green → better than 70% of best; orange → better than 40% of best; red → worse than 40% of best)

Population size	Sum	Crossover fraction	Sum	Cr. heuristic parameter	Sum
200	172	0.4	125	1.1	94
125	86	0.6	97	1.2	148
100	106	0.8	66	1.4	124
50	2	0.9	78		

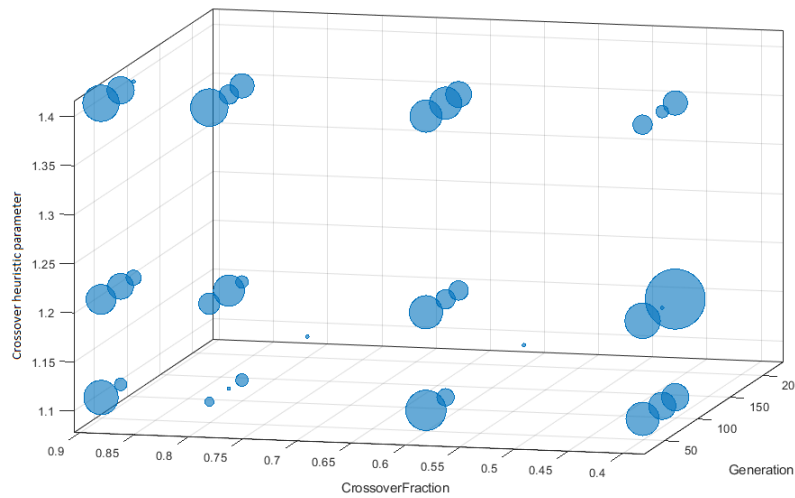

Fig. 5.2. The Visualisation of Number of Correct Solutions Corresponding to Values of Selected Behavioral Parameters of MOGA

As it can be seen in Tab. 5.1, the highest number of results can be found using the largest population size set to 200 individuals, the crossover fraction set to 0.4 and the crossover heuristic parameter set to 1.2. During the testing phase, the configuration with the above values of parameters found the largest number of correct results.

5.2.2 Qualitative Analysis of MOGA Results

Due to multi objective optimization used in MOGA, optimal results were presented in the form of Pareto front. For the first check with most of the results, all were printed on a diagram with cost (c_3) of the solution on X-axis and minimal difference between address (c_2) on Y-axis (Fig. 5.3-5.5). The objective function c_2 was calculated from the Eq. 4.7. Colour code informs about a type of an optimization process (see Tab. 5.2). What is worth

Tab. 5.2. Colour Codes for Figures

	Generation (population size)	Crossover fraction	Crossover heuristic param.	Color code in Fig. 5.3-5.5
value	50 (200)	0.4	1.1	red
	80 (125)	0.6	1.2	blue
	100 (100)	0.8	1.4	green
	200 (50)	0.9		yellow
Solutions from LHS				Black

noticing, GA parameters which generated higher number of results, were not the ones which generated the best results.

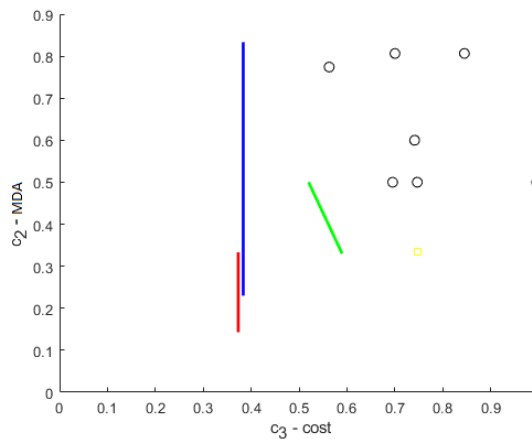

Fig. 5.3. The Visualisation of Optimal Solutions for Different Number of Generations and Population Sizes

5.2.3 Best Solutions from MOGA

Comparing the best results from quantitative and qualitative perspectives, it can be expected that the best results are from the simulation with a population (pop) of 200 individuals, the crossover fraction (Cfra) set to 0.4 and the crossover heuristic parameter (Cheu) set to 1.1, which is not the case. The algorithm with the highest number of results did not deliver optimal solutions. It is clearly visible that LHS usually gives us the worst results. There was only one case where GA delivered worse results than LHS. As for the results, almost all variants of GA configuration delivered a different spectrum of solu-

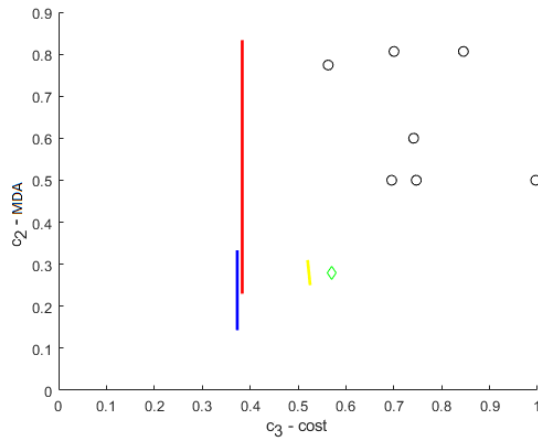

Fig. 5.4. The Visualisation of Optimal Solutions for Different Values of the Crossover Fraction

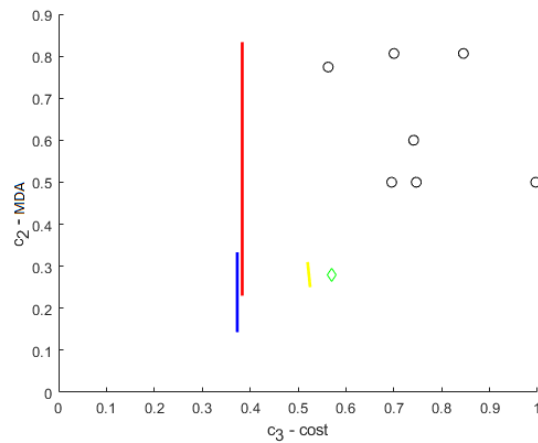

Fig. 5.5. The Visualisation of Optimal Solutions for Different Values of the Crossover Heuristic Parameter

tions, which is a different local minimum. Only two configurations of values of behavioral parameters such that $pop=200$, $Cfra=0.6$, $Cheu=1.1$ and $pop=200$, $Cfra=0.9$, $Cheu=1.2$ (results shown in Tab. 5.3) delivered solutions from a few local minima. However, all variants of MOGA algorithm found all optimal results with the same two decision variables, it means the strategies of using coils and capacitors (P_{s4}) and the addresses' trend (P_{s7}) always have the same value.

Tab. 5.3. The Comparison of Selected Optimal Values of Decision Variables for MOGA

Population	Cfra	CHP	c_2	c_3	p_{s_1}	p_{h_1}	p_{h_2}	p_{h_3}	p_{h_4}	p_{s_2}	p_{s_3}	p_{s_4}	p_{s_5}	p_{s_6}	p_{s_7}	p_{h_5}	p_{h_6}	p_{h_7}
200	0.6	1.1	0.01	0.73	72	8	3	4	3	271	19	3	1	2	2	6	0	0
200	0.9	1.2	0.01	0.74	57	6	4	3	9	556	34	2	3	1	2	6	0	0

Tab. 5.4. Best Results of MOGA

no.	p_{s_1}	p_{h_1}	p_{h_2}	p_{h_3}	p_{h_4}	p_{s_2}	p_{s_3}	p_{s_4}	p_{s_5}	p_{s_6}	p_{s_7}	p_{h_5}	p_{h_6}	p_{h_7}
1	25	5	5	1	4	659	23	4	6	2	2	4	1	1
2	45	5	6	9	2	786	30	4	3	1	2	3	0	1
3	25	5	5	1	4	659	23	4	6	2	2	4	1	1
4	64	4	7	7	1	527	13	4	5	0	2	3	0	1
5	68	7	6	5	4	185	7	4	5	2	2	4	1	0
6	48	4	6	8	2	791	27	4	4	1	2	3	1	1
⋮	⋮	⋮	⋮	⋮	⋮	⋮	⋮	⋮	⋮	⋮	⋮	⋮	⋮	⋮
74	35	5	7	7	6	532	8	4	5	1	2	3	0	1

5.2.4 Analysis of all MOGA Results

From all simulations with different parameters of MOGA, the author collected 700 results of correct auto-addressing (calculated a sum from all last generations). There were 480 000 calls of the fitness function. The variant with the highest number of results had 0.48% success rate, and the worst one 0%. Due to the high volume of data, the author sorted the best results (from spectrum of all variants of MOGA) to check for relations between decision variables. The results were sorted according to a global criterion given by Eq. 4.9.

As it is presented in Tab. 5.4, 74 best results characterized by the same value of P_{S_4} and P_{S_7} . P_{S_4} describes the strategy of using LC terminators (coils and capacitors). The fourth strategy was selected. It involves connecting all LC terminators and then with each second iteration disconnecting one of it. More on that is given in chapter 4.2. P_{S_7} defines what the trend of correct addressed modules has to look like. The algorithm selected the second one which described a rising trend, which means that nodes which are further from the master disconnect LC terminators later.

Parameter P_{S_5} defines the method of data analysing (more details are present in Chapter 4.2). It was never set to 7 where the result of analysed data is the difference between

the maximal and the minimal values. The median was used very occasionally. The most frequently used method was the fifth one - which is described by equation:

$$\mathbf{P}_{s_5} = \frac{\sum_{i=0}^{25} T_i - T_{max}}{\text{size}(T)}, \quad (5.1)$$

where T_i is i -th value from ADC in auto-addressing circuit.

This equation returns a kind of average value but without considering the maximum value, which can be caused by interference. The MATLAB function 'mode' which returns the most often used value from vector T is another frequently used method.

Parameters P_{h_6} and P_{h_7} probably have no impact on the result due to almost the same number of cases without using termination resistor. In master board this resistor was used in 55% of results and in clients boards this resistor was used in 50% of results.

Unfortunately, there was no visible trend of the repeatability of parameters $P_{h_1} - P_{h_4}$, which are the most important parameters, due to their impact on a hardware part of the interface.

5.2.5 Summary of MOGA Optimization

The results show how important setting correct optimization parameters is. There was no significant influence of C_{fra} and C_{he} , but the size of the population has a considerable influence on both quantitative and qualitative outcomes. Table 5.1 shows that the crossover fraction set to 0.4 and the crossover heuristic parameter set to 1.2 are the best parameters for the current approach.

5.3 Optimization Results Obtained Using PSO

The author checked 36 different configurations of PSO algorithm, characterised by the following configuration: the swarm population was equal to 50, 100, 200 individuals; the self adjustment weight (b_1) was set to 0.5, 1.5, 2.5, 3.5; the social adjustment weight was calculated applying Eq. 4.19; the minimum neighbour fraction (MNF) was equal to 0.12, 0.25 and 0.5. Each configuration was examined by calling 10000 times the objective function in the form of Eq. 4.9.

5.3.1 Quantitative Analysis of PSO Results

Figure 5.6 was created for quantitative analysis of optimization results obtained by PSO algorithm. The size of the bubble represents the quantity of correct results. It is clearly visible that setting optimal values of behavioral parameters of this algorithm is more important than in the MOGA case. Moreover, the same conclusion may be formulated as in MOGA, which means that the better solutions can be found when the bigger swarm population is used. The author received 51 correct solutions during tests in which the swarm size was equal to 200. Parameters such as the minimal neighbour fraction and the self adjustment weight have been well estimated due to a lot of results in the middle of parameter spectrum. The complete comparison of parameters' influence on the number of results can be seen in Tab. 5.5 and 5.6.

Tab. 5.5. PSO Parameters and Colour/Shape Codes for Figures

	Swarm size	b_1	Colour code in Fig. 5.7-5.9	MNF	Symbol in Fig. 5.7-5.9
value	50	0.5	red	0.12	+
	100	1.5	blue	0.25	x
	200	2.5	green	0.5	◇
		3.5	yellow		<i>square</i>

Tab. 5.6. The Sum of Correct Results Using Proposed Values of PSO Parameters (Colour Code: green → the best; Light green → better than 70% of best; orange → better than 40% of best; red → Worse than 40% of best)

Swarm size	sum	b_1	sum	MNF	sum
50	14	0.5	29	0.12	20
100	28	1.5	43	0.25	45
200	51	2.5	20	0.5	28
		3.5	1		

5.3.2 Qualitative Analysis of PSO Results

PSO algorithm was designed taking into consideration the optimization criterion function according to Eq. 4.9. The author cannot mark the best results on Pareto front because PSO algorithm was used for single objective optimization. There are 14 clients

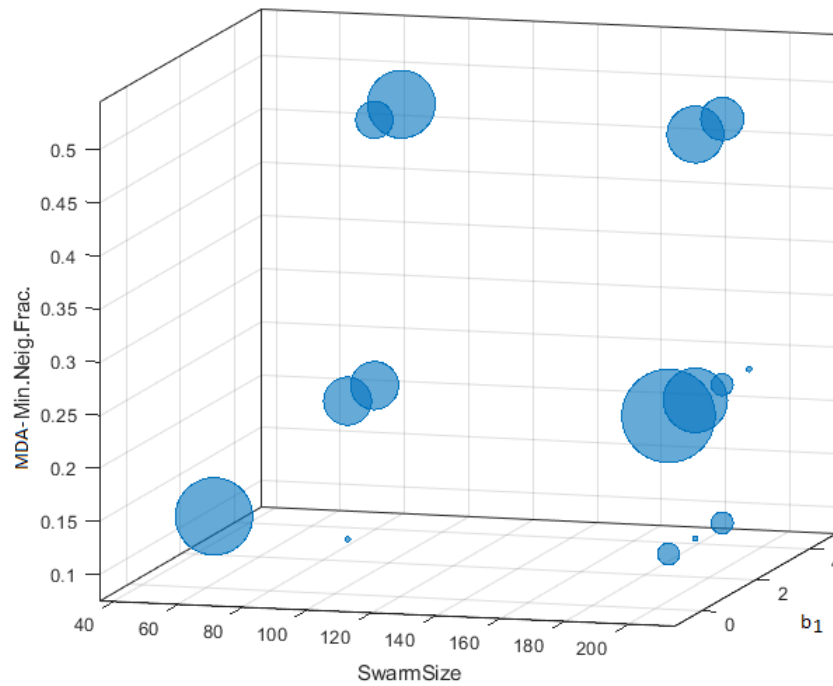

Fig. 5.6. The Bubble Visualization of Quantitative Results of Different PSO Configurations

online, which means there are 13 areas nodes. If fewer addresses are correct, the objective function c_1 will return a higher value. The criterion function c_3 represents the cost of the current solution, whereas the criterion function c_2 is used to estimate the minimal difference between addresses. Figure 5.6 represents alternative solutions of PSO algorithms. Shape and colour code were shown in Tab. 5.6. As you can see, higher swarm size yields to better results, but even in the smallest swarm size there was one result with c_2 close to 0.2 (c_2 has the higher weight according to Eq. 4.7). The function c_2 should have a minimum value of 0.5 which was achieved only two times for the swarm size of 50, four times for the swarm size set to 100, and nine times for the case when the swarm size was equal to 200. This led the author to the conclusion that the number of correct solutions is growing proportionally to the swarm size. Based on Tab. 5.6 if minimum neighbour fraction is set to 3.5, the chances of finding a multiple solution are low, therefore, the maximum correct solution in the current approach will be 9. Hence the final conclusion is that the swarm size has to be set to 200 in order to obtain the correct solution via PSO algorithm.

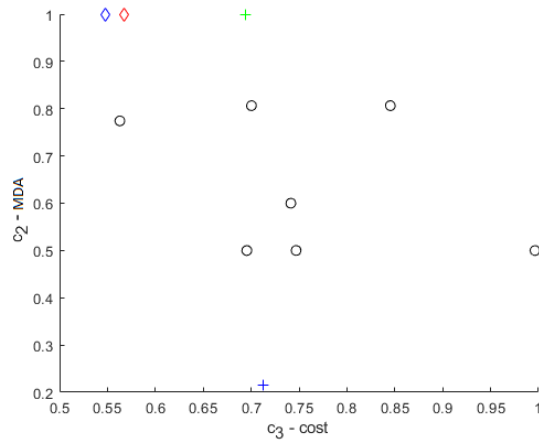

Fig. 5.7. Results of PSO Obtained for the Swarm Size = 50

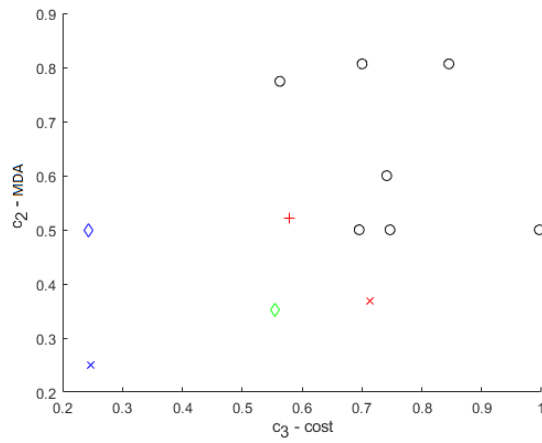

Fig. 5.8. Results of PSO Obtained for the Swarm Size = 100

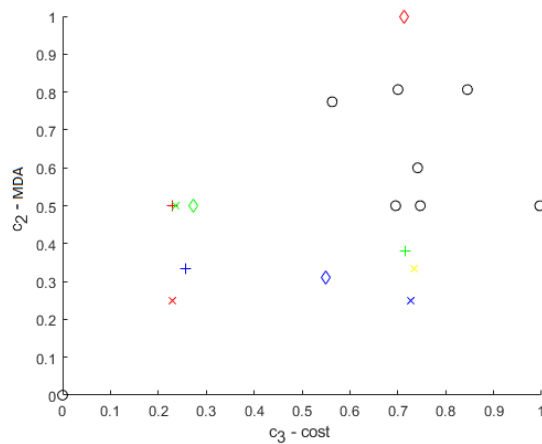

Fig. 5.9. Results of PSO Obtained for the Swarm Size = 200

5.3.3 Analysis of all PSO Results

PSO algorithms with different parameters identified 231 results (calculated as a sum from all last generation) from 360 000 calls of the objective function. It represents 0,064% on average. That is less than half as much compared to MOGA. However, the number of results is not as important as the quality. The best configuration had 0.4% of correct results, the worst did not find any results. Due to the high volume of data, the author sorted the best results (from spectrum of all variants of PSO) to check for relations between decision variables. The results have been sorted according to a global criterion 4.9. From all 231 results, only 8 results have different P_{S_4} and P_{S_7} then others, where the first one was on 211st position. P_{S_4} and P_{S_7} are more precisely described in section 4.2 and subsection 5.2.4.

P_{h_5} which defined coil to be used in pulse generator, was set to 5 in almost all results, only in 19 cases from 231 the value was different, and excluding two cases, was set to 3. Here is a difference between MOGA due to many results in P_{h_5} for MOGA optimization trials.

Parameter P_{S_5} defined the method of data analysing (more details can be found in section 4.2. It took only three values, similarly to MOGA - function mode and Eq. 5.1 was often used. Additionally, very frequently the minimum value from vector T was used (the value of P_{S_5} parameter was equal to 3). Except these three methods, no other was achieved.

Parameters P_{h_6} and P_{h_7} in MOGA are characterized by almost 50/50% split. It is different in PSO algorithm, where in about 70% (both master and clients) cases this value was set to 1.

The next difference between MOGA and PSO is that parameters P_{h_1} - P_{h_4} are more stable. The parameter P_{h_2} which is responsible for selecting a coil on master board was in 90% cases set to a value where no coil is connected to the line. The parameter P_{h_4} which is responsible for selecting a coil on client board, in 70% cases selected the lower value of coil or even no coil at all. That has significantly influenced cost of analysed setup in further industrialization.

5.3.4 Summary of PSO

It is clearly visible that LHS algorithm regularly gives worst results, however in case of using a bad algorithm configuration, LHS is able to deliver better results. As for the results, on the upper diagrams, the author marked 19 results — the best from each algorithm configuration. In Fig. 5.8 and Fig. 5.9 “x” in the bottom-left corner can be found, two solutions are visible, they are the best results from all tests the author conducted. Comparing both points, and all other points (not shown in figures) from these two configurations, the author noted that only one decision variable is not the same in all algorithms’ configuration.

5.4 Summary of all Optimization Results

To summarise, the best results were achieved by PSO (for the swarm size set to 200, MNF set to 0.5 and SeAW set to 0.25) confirmed by Eq. 4.9. The best MOGA solution is 59%, and the best LHS is 245% more expensive (criterion function c_3) compared to the PSO one. However, the best MOGA solution is characterized by three times better MDA than PSO (in this particular case the cost is 3.23 times higher than in the best result), and the best LHS is characterized two times worse in the case of c_2 compared to PSO.

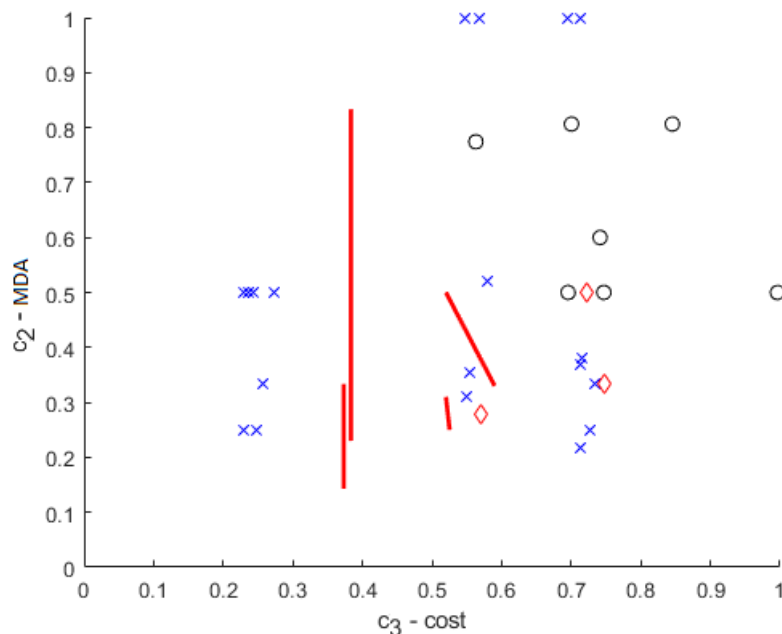

Fig. 5.10. Overall Optimization Results Obtained by all the Algorithms (black Ball — LHS, red Fronts and Diamonds — MOGA, blue x — PSO)

5.5 Industrialization Potential

Due to the implementation nature of the thesis, the best results have to be checked according to the automotive industry standards. Such tests can be performed after the final implementation is prepared, which is not possible in this phase of DLN solution. During all laboratory tests, and on proof of concept stand with real clients equipped with sensors and actuators, it has been confirmed beyond doubt that the communication layer is working very well. The author wanted to make sure of auto-addressing stability. That is why additional tests were planned, to prove suitability of the proposed interface for auto-addressing systems and to select final parameters.

Particle swarm optimization and genetic algorithm found multiple solutions of the described problem. It is difficult to compare all solutions from the Pareto front to one criteria result from PSO. Therefore, all results were analysed as a result of global criteria Eq. 4.9, with the following weights $w_1 = 0.9$ (the weight of the minimal difference between addresses c_2) and $w_2 = 0.1$ (the weight of the cost of the solution c_3). The author decided to choose six configurations, the best two from LHS, PSO and two from MOGA, the one with the highest number of correct addressed clients, and one each with best results. The configuration is shown in Tab. 5.7. For MOGA, the brackets contain, the methodology of choosing results, most findings (M) or best findings (B).

When analysing the results, some parameters were almost the same in all correct results. The exception is in LHS which is further from the optimum than PSO or GA. Table 5.8 shows the result of global criteria Eq. 4.9. The table does not show criterion c_1 (Eq. 4.5) due to its specificity, which is a condition for auto-addressing. That means all positions in the Tab. 5.8 are characterized by the same value of this criterion.

The author carried out a test where each auto-addressing configuration was repeated 5000 times, see Fig. 5.11. The results show, when analysing each of the position separately, and after carrying out e.g. ten auto-addressing tests, the position on the line can be calculated with probability of 90% to successful address. Additionally, when there are fewer than 12 nodes, the probability increases to about 95%.

The result from LHS is surprisingly good, considering c_3 equal to 0.77 in this configuration. Fig. 5.11 shows that in case of separate analyses of each node, success rate is about 90% for each solution when there are ten or fewer nodes on the line.

That was not satisfactory to the author, that is why the results had to be processed by Kalman filter [63]. During configuration of Kalman filter the first estimation can be set

Tab. 5.7. The Comparison of Optimal Values of Decision Variables

Algorithm	GA:population / PSO: swarm size	GA:Cfra / PSO: MNF	GA:CHP / PSO: SAW	p_{s_1}	p_{h_1}	p_{h_2}	p_{h_3}	p_{h_4}	p_{s_2}	p_{s_3}	p_{s_4}	p_{s_5}	p_{s_6}	p_{s_7}	p_{h_5}	p_{h_6}	p_{h_7}
PSO	200	0.5	0.25	26	8	9	2	9	6	5	4	3	3	2	2	1	1
PSO	200	0.5	0.25	25	8	9	5	9	1	2	4	3	2	2	2	0	1
MOGA (M)	200	0.4	1.2	84	4	4	9	2	869	8	4	0	0	2	3	0	0
MOGA (B)	125	0.4	1.1	25	5	5	1	4	659	23	4	6	2	2	4	1	1
LHS				69	3	4	8	2	300	20	4	4	2	2	6	0	1
LHS				20	4	5	2	2	629	15	3	5	0	3	3	0	1

Tab. 5.8. Optimization Results Comparison Taking into Consideration Industrialization Potential

Algorithm	GA:pop / PSO: swarm size	GA:Cfra / PSO: MNF	GA:Cheu / PSO: SeAW	C (global criteria)	c_2 (cost)	c_3 (MDA)
PSO	200	0.5	0.25	0.01907	0.22976	0.25
PSO	200	0.5	0.25	0.01920	0.24726	0.25
GA (M)	200	0.4	1.2	0.03742	0.36528	0.5
GA (B)	125	0.4	1.1	0.01148	0.74332	0.08
LHS				0.03996	0.6955	0.5
LHS				0.05792	0.56298	0.77

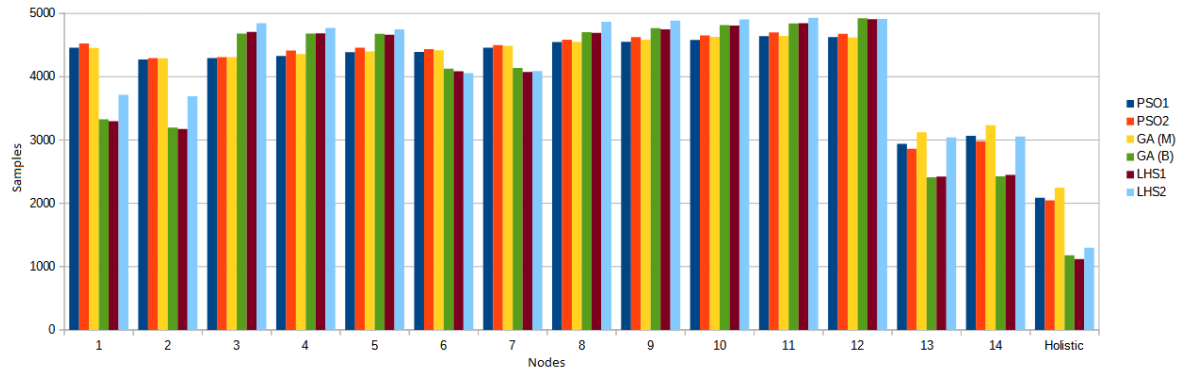

Fig. 5.11. The Comparison of Correct Addresses after 5000 Attempts

manually, but during normal operation it would be impossible, that is why, the author had two options: set all initial values to value from the middle (in case of 14 nodes - 7.5), or conduct initial measurement to selected initial values. The second approach was set due to the possibilities to reduce numbers of measurement. The results were analysed statistically.

In the worst case, if the initial and first measurements are wrong, measurements have to be repeated 10 times. Such a scenario, according to the probability calculation, may occur 0,25% situations. The worst case simulation on only two addresses is presented in Fig. 5.12.

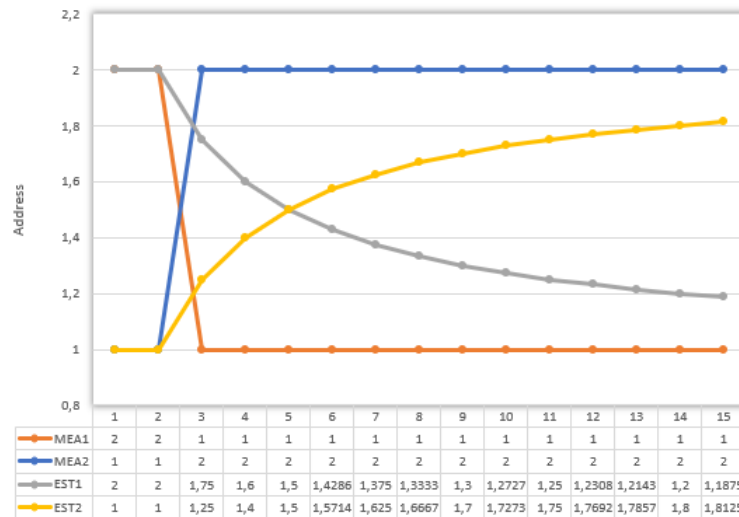

Fig. 5.12. Simulation of Filtering Addresses of two Nodes

In case of wrong initial, or the first measurement (the possibility of 5%), measurements have to be repeated seven times.

To achieve 100% success rate, the author proposes repeating measurements six times filtering results by Kalman filter, and then repeating measurements as long as differences between addresses are not lower than 0.5. Two correct measurements among four wrong ones, set the differences between addresses to lower than 0.5. Chances to get four wrong results in the first six measurements are lower than $6\% \times 10^{-4}$. Two different scenarios of four wrong measurements in period of six is presented in Fig. 5.13 and Fig. 5.14 where an example of two nodes is shown. Respectively MEA1 and MEA3 represent measured values, and EST1, EST2 represent addresses estimated by Kalman filter.

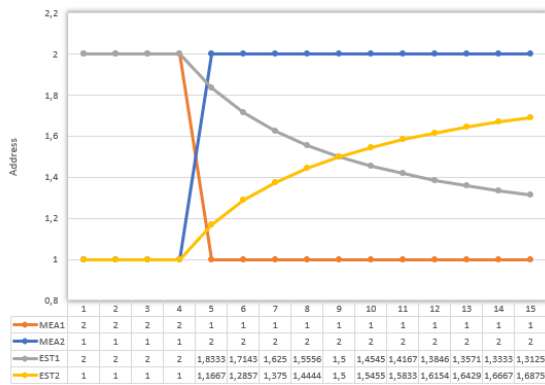

Fig. 5.13. Four Wrong Measurements in a Row

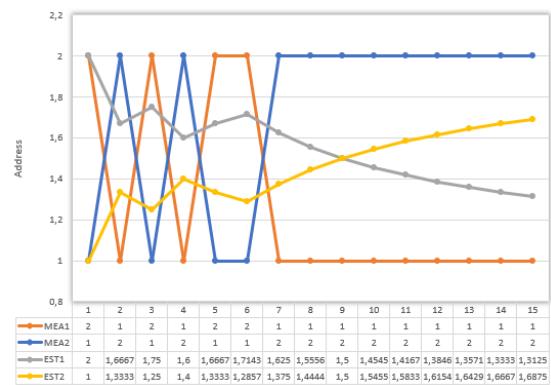

Fig. 5.14. Four Wrong Measurements in Random Places

Figure 5.15 represents estimated addresses in case of 14 nodes. This example was chosen from many others to present how Kalman filtering works when auto-addressing failed by multiple addresses. The third node was wrongly addressed as the first one during initial measurement. In such a case, six measures are not enough to achieve 100% reliability of addressing, but after the second measurement, the required 0.5 difference between addresses is not kept, which informs the algorithm that additional measures have to be taken, achieving 100% success rate after 15 repeats.

The results from PSO and MOGA suggest that reducing the number of measurements to a single one was not the best idea, due to the low noise resistance. Such a decision was dictated by the time frame the author had to finish the project. The first estimation of the time needed for all planned trials (one LHS test, 36 configurations of PSO, 48 configurations of GA, where each setup had 10 000 target function calls) was equal to 186 days (the single test takes 19 s). Finally, the author made an extra effort to optimize the algorithm, which reduced the time to about 120 days. All measurements should be taken three or even five times which will take 360 or 600 days, the author did not have additional time to

test it in such a manner.

Consequently, knowing the best algorithm, the author conducted additional test with three repeats of each measurement. That should guarantee finding a solution which is characterised with higher stability. Extra effort of repeating artificial algorithms (PSO and both configuration of GA), which evaluated results based on multiple test, gives the same results as algorithms with a single test. PSO delivered almost the same values of most of the decision variables. That is visible also in Tab. 5.8 where PSO was repeated twice with the same configuration.

The differences between results of each of the algorithms are too small to confirm this beyond any doubt, however PSO delivered more stable results, characterized with usually better features, in both cost (c_2) and minimal differences (c_3).

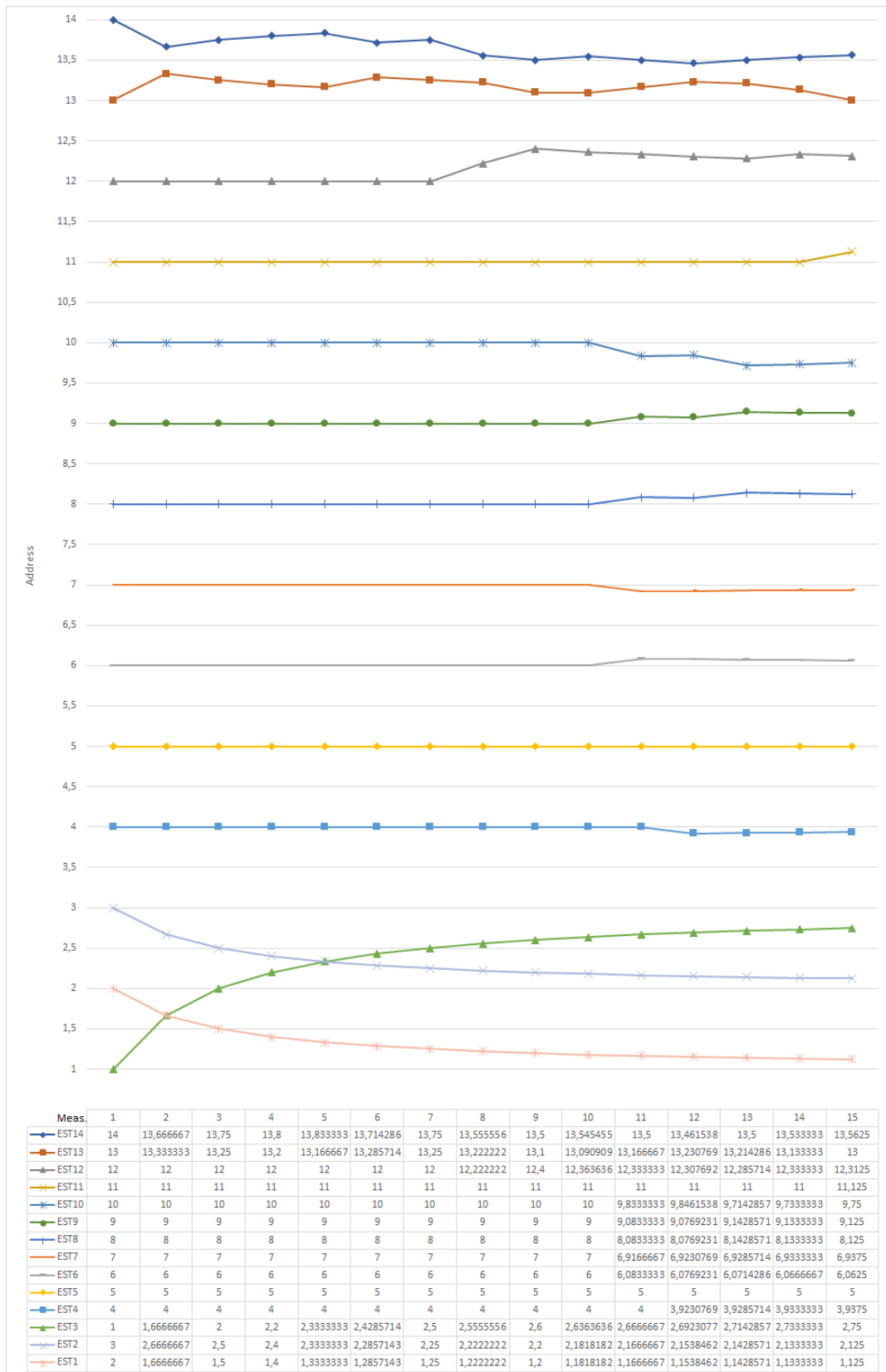

Fig. 5.15. Results of Kalman Filtering for 14 Nodes

6. Implementation to the Industry

The author identified three different areas where the solution can be implemented in the industry. One of the points has to be delayed in implementation due to the current silicon crisis [22] which can result in businesses' priority alterations. The second one is in the implementation process in the company, whereas the third one has already been implemented.

The most important accomplishment is the new interface. The proposed DLN can be implemented in new cars after real life tests and admission test. DLN can be commonly used in QM solutions, with redundancy even in higher ASIL [8]. DLN can reduce from 19% to 39% of CO₂ emission or from 27% to 44% of used cable. The mass reduction of copper can be up to 36% and PCV used for insulation up to 42%.

The proposed HIL-based optimization method, which was used to adjust auto-addressing parameters, has a practical potential. It is proven that it is a perfect method to adjust physical hardware and software parameters when the optimal solution is not known. It can be used in the future for solving similar problems in the author's workplace. As it was shown in the comparison between algorithms and Latin Hypercube Sample, it is challenging to randomly select the appropriate solution in a spectrum of millions of possible solutions. A well configured algorithm solved the problem in less than 24 h, and the time was mainly dictated by the length of measurement.

The third idea was virtually not planned at the beginning of the research. The author equipped all boards with multiple LEDs to indicate whether all of the hardware elements and software features were used in the correct way. Due to the lack of possibility to connect additional devices to the client during auto-addressing when galvanic insulation was required. Eventually, the author used a camera with fast sample rate, 480 fps. Such a simple camera allows for galvanic isolated logic analysis on 369 channels (with potential to thousands) at time resolution in the range of 2 ms. This idea is already implemented in the company for fast measurements where the resolution is at the level 2 ms, or 1 ms in case of 960 fps camera, is sufficient.

7. Conclusions

The goal of this research was to develop and test a power and communication bus, with a focus on developing and finding the best hardware and software features for auto-addressing. All goals have been achieved. The bus has been developed with much better parameters than expected, it is up to four times faster (up to 2 Mbps, where 512 kbps was the target), and can transfer up to 480 W (48 V and 10 A) where the minimal goal was set to 2 A.

The proposed interface, named Device Lightweight Network (DLN) is a cutting-edge technology which can significantly reduce the number of cables in cars and other areas of industry. The simplification of the harness has a profound impact on the CO₂ footprint reduction, weight of a car, development, production and maintenance costs reduction by decreasing the designing time, used materials and simplification. The author is confident that the proposed solution can be utilized in all non-safety applications in cars, and other industry sectors. The proposed technology can be used for higher ASIL solutions by using two redundant DLNs. The cost of example usage is much lower than the current solution.

The author proposed the new method integrating the HIL technique with genetic algorithm, particular swarm optimization and Latin Hypercube Sampling method for rapid prototyping of DLN. In this way, it was possible to check multiple hardware features and software parameters of DLN and to select the best one to ensure proper operation of the auto-addressing function. The best results were achieved by using artificial intelligence algorithms, in both variants of the solution and difference between modules addresses. Both of the two used algorithms achieve better results for highest population size (the number of individuals and the swarm size). Particle swarm optimization delivered the best results in the tested approach.

Based on the results of the work, the following specific conclusions can be drawn:

- Developed Device Lightweight Network can deliver high-power supply (10 A / 48 V, 480 W) and fast data transmission (up to 2 Mbps), with auto-addressing on one pair of wires.

- Computational intelligence algorithms such as PSO and GA appropriate in a multi-variable decision environment where it is difficult to determine the optimal values of the decision variables by classic engineering methods.
- The proposed DLN can contribute to reduce CO₂ emission during production of a harness.
- The proposed method for prototyping of mechatronic automotive systems based on the HIL technique supported by algorithms of computational intelligence can be successfully used for the development of new products of the DRÄXLMAIER company.
- The proposed DLN can be implemented in new cars after real life tests and admission tests, which are planned to be done in DRÄXLMAIER company.
- Other soft computing optimization algorithms, such as Grey Wolf Optimizer, Artificial Bee Colony, Gravitational Search, Simulated Annealing algorithms etc. will be taken into consideration in the future research of the author.

Bibliography

- [1] Technical report, California Air Resources Board. <https://ww2.arb.ca.gov/homepage>, (Accessed 08-7-2021).
- [2] About european union. Technical report, EU. https://europa.eu/european-union/about-eu/countries_en#tab-0-0, (Accessed 08-10-2021).
- [3] Data sources and assumptions for the electricity sources and emissions tool. Technical report, Alternative Fuels Data Center. https://afdc.energy.gov/vehicles/electric_emissions_sources.html, (Accessed 08-1-2021).
- [4] Hellermannntyton products. <https://www.hellermannntyton.com/products/application-tooling?competence>, (Accessed 09-20-2021).
- [5] Open charge alliance, description of "open charge point protocol". <https://www.openchargealliance.org/> access: 10.09.2021.
- [6] Unitek-elektrik. <http://unitek-elektrik.com/en>, (Accessed 06-7-2021).
- [7] EV1 attracts strong interest on debut. *Metal Powder Report*, 52(1):23, 1997.
- [8] ISO 26262 Road vehicles — Functional safety. Technical report, International Organization for Standardization, 2011.
- [9] Car wires. 2015. https://at.prysmiangroup.com/sites/default/files/atoms/files/Katalog%20Automotive_122015.pdf, (Accessed 06-20-2021).
- [10] ISO 11898 Road vehicles — Controller area network (CAN). Technical report, International Organization for Standardization, 2015.
- [11] Audi continues rollout of standard 48V mild hybrid system with new A6 Avant. Technical report, Green Car Congress, 2018. <https://www.greencarcongress.com/2018/04/20180411-a6.html>, (Accessed 08-15-2021).

- [12] Venezuela salary. Technical report, average salary survey, July 16, 2021.
- [13] AAA. National average gas prices. Technical report, AAA, 2021.
- [14] R.N. Abdullaev, R.A. Khairulin, Yu. M. Kozlovskii, A. Sh. Agazhanov, and S.V. Stankus. Density of magnesium and magnesium-lithium alloys in solid and liquid states. *Transactions of Nonferrous Metals Society of China*, 29(3):507–514, 2019.
- [15] Akeem Whitehead Anand Gopalan. Automatic slave node position detection. Technical report, TexasInstruments, 2015.
- [16] L. Angel, J. Viola, and M. Vega. Hardware in the loop experimental validation of pid controllers tuned by genetic algorithms. In *2019 IEEE 4th Colombian Conference on Automatic Control (CCAC)*, pages 1–6, 2019.
- [17] Audi. Audi A8 – Mild Hybrid Electric Vehicle (MHEV) with active suspension. Technical report, audi-technology-portal, 2017.
- [18] M. Benhachmi, D. Ouazar, Ahmed Naji, Alexander Cheng, and Khalid el Harrouni. Optimal management in saltwater-intruded coastal aquifers by simple genetic algorithm. 2001.
- [19] Meredith Bennett-Smith. Venezuela salary. Technical report, csmonitor, 2012.
- [20] Himanshu Bhojwani, Gaurav Kumar Sain, and Girraj Prasad Sharma. Computerized fuse auto changeover system with rs485 bus reporting multiple iot cloud connectivity avenues. In *2018 3rd Technology Innovation Management and Engineering Science International Conference (TIMES-iCON)*, pages 1–5, 2018.
- [21] Waxman-Markey Bill. American clean energy and security act. Technical report, CBO, 2009.
- [22] Bloomberg. Chip crisis deepens with daimler, jaguar warnings on sales. <https://www.bloombergquint.com/business/global-chip-crisis-worsens-with-jaguar-warning-50-sales-slump>, (Accessed 09-7-2021).
- [23] Péter Böröcz. Averaged vibration levels during courier parcel delivery service in small truck in hungary. *FME Transactions*, 46(2):211–217, 2018.

- [24] Janez Brest, Sao Greiner, Borko Boskovic, Marjan Mernik, and Viljem Zumer. Self-adapting control parameters in differential evolution: A comparative study on numerical benchmark problems. *IEEE Transactions on Evolutionary Computation*, 10(6):646–657, 2006.
- [25] Henning P.C. Buitendach, Rupert Gouws, Christiaan A. Martinson, Carel Minnaar, and Dmitri Bessarabov. Effect of a ripple current on the efficiency of a pem electrolyser. *Results in Engineering*, 10:100216, 2021.
- [26] Luca Caberletti, K. Elfmann, M. Kummel, and Christoph Schierz. Influence of ambient lighting in a vehicle interior on the driver’s perceptions. *LIGHTING RESEARCH & TECHNOLOGY*, 42:297–311, 09 2010.
- [27] Erran Carmel, Yael Dubinsky, and J. Espinosa. Follow the sun software development: New perspectives, conceptual foundation, and exploratory field study. pages 1 – 9, 2009.
- [28] In Sook Choin. Power line communication method for transmitting data signal with splttng of power transmission interval. US 8659181 B2, Feb. 25, 2014.
- [29] M. Clerc and J. Kennedy. The particle swarm - explosion, stability, and convergence in a multidimensional complex space. *IEEE Transactions on Evolutionary Computation*, 6(1):58–73, 2002.
- [30] Maxwell James Clerk. On governors proc. r. soc. lond. 16:270–283, 1868.
- [31] Benz & CO. Fahrzeug mit gasmotorenbetrieb. Technical report, patent office, 1886.
- [32] International Electrotechnical Commission. Low-voltage switchgear and control-gear - controller-device interfaces. Technical report, International Electrotechnical Commission, 2008.
- [33] European Communities. Regulation (EEC) No 4064/89 - Merger Procedure. Technical report, Office for Official Publications of the European Communities L-2985 Luxembourg, 17/03/1999.
- [34] Cosmic-corp. Cosmic-corp operational sequence figure. http://cosmic-corp.com/pdf/Operational_Sequence.pdf, (Accessed 10-14-2021).
- [35] Cosmic-corp. Cosmic-corp products. <http://cosmic-corp.com/product.html>, (Accessed 10-14-2021).

- [36] Daimler. Mercedes-Benz GLC F-CELL: Two electrical energy sources: battery and fuel cell. Technical report, Daimler.
- [37] Daimler. Technology strategy for electrification: World premiere of mercedes-benz fuel-cell concept truck. Technical report, Daimler.
- [38] Charles Darwin. *The Origin of Species: By Means of Natural Selection, or the Preservation of Favoured Races in the Struggle for Life*. Cambridge Library Collection - Darwin, Evolution and Genetics. 6 edition, 2009. Cambridge University Press.
- [39] Kalyanmoy Deb. *Multi-Objective Optimization using Evolutionary Algorithms*. 2001. John Wiley & Sons.
- [40] M. Deb. *Multi-Objective Optimization Using Evolutionary Algorithms*. 2009. Wiley.
- [41] Angela Di Febbraro and Nicola Sacco. Open problems in transportation engineering with connected and autonomous vehicles. *Transportation Research Procedia*, 14:2255–2264, 2016. Transport Research Arena TRA2016.
- [42] Mark Dooner, Jihong Wang, and Alexandros Mouzakitis. Development of a simulation model of a windshield wiper system for hardware in the loop simulation. In *2013 19th International Conference on Automation and Computing*, pages 1–6, 2013.
- [43] eMining. Emining uses the latest technology. 09.11.2021. <http://emining.ch/en/technology.html>.
- [44] Ford. THE MODEL T. Technical report, Ford, 2019. <https://corporate.ford.com/articles/history/the-model-t.html>, (Accessed 03-1-2021).
- [45] Ford. Exterior lighting history. Technical report, Ford, 2021. <https://corporate.ford.com/articles/history/exterior-lighting-history.html>, (Accessed 03-1-2021).
- [46] GasHD. Hydrogen - H2 (In Polish. Wodór – H2). Technical report, GasHD. <http://gashd.eu/wodor-h2/>, (Accessed 08-1-2021).
- [47] Globalpetrolprices. Venezuela gasoline prices, liter, 12-jul-2021. Technical report, Globalpetrolprices, 2021.

- [48] GM. Chevrolet-malibu-hev-2007-2009. Technical report, GM Service Technical College, 2007.
- [49] David E Goldberg and John Henry Holland. Genetic algorithms and machine learning. 1988. Kluwer Academic Publishers-Plenum Publishers.
- [50] Kwaśnicka H. Artificial intelligence. Evolutionary algorithms - examples of application (in Polish. Sztuczna inteligencja. Algorytmy ewolucyjne - przykłady zastosowań). 2002. Oficyna Wydawnicza PWr.
- [51] I.A. Hassan, Haitham S. Ramadan, Mohamed A. Saleh, and Daniel Hissel. Hydrogen storage technologies for stationary and mobile applications: Review, analysis and perspectives. *Renewable and Sustainable Energy Reviews*, 149:111311, 2021.
- [52] Maximilian Held. Lifespans of passenger cars in europe: empirical modelling of fleet turnover dynamics. *European Transport Research Review*, 13, 01 2021.
- [53] Michael Held and Michael Baumann. Assessment of the environmental impacts of electric vehicle concepts. *Towards Life Cycle Sustainable Management*, 2011.
- [54] John Henry Holland et al. *Adaptation in natural and artificial systems: an introductory analysis with applications to biology, control, and artificial intelligence*. 1992. MIT press.
- [55] F.R. Holmstrom, J.B. Hopkins, A.T. Newfell, and E.F. White. A microwave anticipatory crash sensor for activation of automobile passive restraints. *IEEE Transactions on Vehicular Technology*, 22(2):46–54, 1973.
- [56] Ronald Iman, J. Campbell, and J. Helton. An approach to sensitivity analysis of computer models. *I-Introduction, input, variable selection and preliminary variable assessment. J. Qual. Technol*, 13:174–183, 01 1981.
- [57] Ronald Iman and William Conover. Small sample sensitivity analysis techniques for computer models, with an application to risk assessment. *Communications in Statistics-theory and Methods - COMMUN STATIST-THEOR METHOD*, 9:1749–1842, 1980.
- [58] Japan Automobiles Research Institute. Overall efficiency and ghg emissions. 2010.
- [59] A. Janiak. *Selected problems and algorithms for task scheduling and resource allocation (in Polish. Wybrane problemy i algorytmy szeregowania zadań i rozdziatu*

- zasobów). Problemy Współczesnej Nauki: Informatyka. 1999. Akademicka Oficyna Wydawnicza PLJ.
- [60] Adam Janiak and Przemysław Kobylański. A genetic algorithm for solving a flow handling problem with resources (in Polish. Algorytm genetyczny rozwiązujący przepływowy problem obsługi z zasobami). 2006. Wydawnictwo Politechniki Śląskiej.
- [61] Romania Journal. How many litres of petrol can you buy with an average salary in europe and around the world? Technical report, Romania Journal, Aug 1, 2019.
- [62] Kabatec. Kabatec web page. <https://www.kabatec.com/EN/>, (Accessed 09-1-2021).
- [63] R. E. Kalman. A New Approach to Linear Filtering and Prediction Problems. *Journal of Basic Engineering*, 82(1):35–45, 03 1960.
- [64] W. Kaltner, M. Veprek-Heijman, A. Jentys, and J.A. Lercher. Effect of chromium migration from metallic supports on the activity of diesel exhaust catalysts. *Applied Catalysis B: Environmental*, 89(1):123–127, 2009.
- [65] Andrzej Katunin and Piotr Przystałka. Damage assessment in composite plates using fractional wavelet transform of modal shapes with optimized selection of spatial wavelets. *Engineering Applications of Artificial Intelligence*, 30:73–85, 2014.
- [66] Małgorzata Kawecka. Our guiding principles; for the climate (in Polish. Nasze zasady przewodnie; dla klimatu). Technical report, Draexlmaier Polska.
- [67] James Kennedy, Russell C. Eberhart, and Yuhui Shi. Preface. In *Swarm Intelligence*, The Morgan Kaufmann Series in Artificial Intelligence, pages 13–27. San Francisco, 2001. Morgan Kaufmann.
- [68] O. Khaselev, A. Bansal, and J.A. Turner. High-efficiency integrated multijunction photovoltaic/electrolysis systems for hydrogen production. *International Journal of Hydrogen Energy*, 26(2):127–132, 2001. Third International Symposium on New Materials, Renewable Energy and Environment.
- [69] Michał Kij. Mercedes-Benz 300 SL „Gullwing”. <https://www.motofakty.pl/artykul/mercedes-benz-300-sl-gullwing.html>, (Accessed 07-15-2021).

- [70] Klaus Kivekäs, Antti Lajunen, Francesco Baldi, Jari Vepsäläinen, and Kari Tammi. Reducing the energy consumption of electric buses with design choices and predictive driving. *IEEE Transactions on Vehicular Technology*, 68(12):11409–11419, 2019.
- [71] Stefan Koehler, Alexander Viehl, Oliver Bringmann, and Wolfgang Rosenstiel. Optimized recuperation strategy for (hybrid) electric vehicles based on intelligent sensors. pages 218–223, 2012.
- [72] Komax. Komax annual raport 2019.
- [73] Komax. Komax Sigma 688. <https://www.komaxgroup.com/en/Products-and-Solutions/Products/Twister/Sigma-688/>, (Accessed 08-2-2021).
- [74] Komax. Komax web page. <https://www.komaxgroup.com/en/>, (Accessed 08-2-2021).
- [75] Dierikon komax Holding AG. Device for assembling a plug housing. US Patent 10,804,668 B2, Oct. 2 , 2017.
- [76] Dierikon komax Holding AG. Method and device for aligning prefabricated cable ends of a cable harness in correct rotational position. US10723584B2, Oct. 2 , 2017.
- [77] Shoki Kosai, Masaki Nakanishi, and Eiji Yamasue. Vehicle energy efficiency evaluation from well-to-wheel lifecycle perspective. *Transportation Research Part D Transport and Environment*, 65:355–367, 2018.
- [78] Adam Kostrzewa and Rolf Ernst. Achieving safety and performance with reconfiguration protocol for ethernet tsn in automotive systems. *Journal of Systems Architecture*, 118:102208, 2021.
- [79] Marlene Kuhn and Huong Nguyen. The future of harness development and manufacturing - results from an expert case study. 2019.
- [80] LEONI. Harness market teach-in. Technical report, LEONI, 2019.
- [81] Renjun Li, Chu Liu, and Feng Luo. A design for automotive can bus monitoring system. In *2008 IEEE Vehicle Power and Propulsion Conference*, pages 1–5, 2008.
- [82] Jun Liu. *Monte Carlo Strategies in Scientific Computing*. 2009.

- [83] Yu Liu, Xing Shu, Hanzhengnan Yu, Jiangwei Shen, Yuanjian Zhang, Yonggang Liu, and Zheng Chen. State of charge prediction framework for lithium-ion batteries incorporating long short-term memory network and transfer learning. *Journal of Energy Storage*, 37:102494, 2021.
- [84] Frederic Magoules and Barry Topping. High performance computing for computational mechanics. *Computers & Structures - COMPUT STRUCT*, 85:487–488, 2007.
- [85] Montaser Mahmoud, Mohamad Ramadan, Sumsun Naher, Keith Pullen, Mohammad Ali Abdelkareem, and Abdul-Ghani Olabi. A review of geothermal energy-driven hydrogen production systems. *Thermal Science and Engineering Progress*, 22:100854, 2021.
- [86] Denis Makartetskiy, Guido Marchetto, Riccardo Sisto, Fulvio Valenza, Matteo Virgilio, Denise Leri, Paolo Denti, and Roberto Finizio. (User-friendly) formal requirements verification in the context of ISO26262. *Engineering Science and Technology, an International Journal*, 23(3):494–506, 2020.
- [87] Maxim. GMSL. Technical report, Maxim. <https://www.maximintegrated.com/en/products/interface/high-speed-signaling/gmsl-serdes.html/tab0>, (Accessed 08-9-2021).
- [88] D.J. McClements and P. Fairley. Frequency scanning ultrasonic pulse echo reflectometer. *Ultrasonics*, 30(6):403–405, 1992.
- [89] M. McKay, Richard Beckman, and William Conover. A comparison of three methods for selecting vales of input variables in the analysis of output from a computer code. *Technometrics*, 21:239–245, 05 1979.
- [90] Melexis. MLX81112 datasheet. Technical report, Melexis, 2013. <https://pdf1.alldatasheet.com/datasheet-pdf/view/884202/MELEXIS/MLX81112.html>, (Accessed 08-10-2021).
- [91] Melanie Mitchell, Stephanie Forrest, and John Holland. The royal road for genetic algorithms: Fitness landscapes and ga performance. 1994.
- [92] MOBY. What are HV / PHEV / PHV / FCV / EV / BEV / HEV? Choosing the recommended green car by car life (in Polish. Co to są HV / PHEV / PHV / FCV / EV

- / BEV / HEV? Wybór zalecanego samochodu ekologicznego według życia samochodu). <https://car-moby.jp/article/car-life/useful-information/hv-phev-phv-fcv-ev-bev-hev/>, (Accessed 08-7-2021).
- [93] Sandy Munro. Bmw i3 reports. Technical report, MunroLive, 2013. <https://munrolive.com/support-%2F-store/ols/products/bmw-i3-reports>, (Accessed 11-7-2020).
- [94] NEF. National energy foundation. 2020. <https://nef.org.uk/>, (Accessed 05-7-2021).
- [95] NEF. National energy foundation; carbon emission calculator. 2020.
- [96] U.S. Department of Labor. Usual weekly earnings of wage and salary workers second quarter 2021. Technical report, U.S. Department of Labor, July 16, 2021.
- [97] Natesan Palanivel and Tingsu Chen. Wiring harness reduction in automotive using li-fi technology. pages 1778–1783, 2017.
- [98] M. Patel. Cumulative energy demand (ced) and cumulative co2 emissions for products of the organic chemical industry. *Energy*, 28(7):721–740, 2003.
- [99] Reinhard Ploss, Anton Mueller, and Patrick Leteinturier. Solving automotive challenges with electronics. pages 1 – 2, 05 2008.
- [100] Ajay Pradhan. Current trends in automotive wire harness design. 2011.
- [101] P.J. Pérez-Martínez, D. Ming, G. Dell’Asin, and A. Monzón. Evaluation of the influence of toll systems on energy consumption and CO2 emissions: A case study of a Spanish highway. *Journal of King Saud University - Science*, 23(3):301–310, 2011. Special Issue on "Advances in Transportation Science".
- [102] JR.Dalibor Zulim Richard L. WESTRICK. Automatic self-addressing method for wired network nodes. Technical report, Patent office, 2010. <https://patents.google.com/patent/US20100274945A1/en>, (Accessed 08-15-2021).
- [103] Hannah Ritchie and Max Roser. CO2 and Greenhouse Gas Emissions. *Our World in Data*, 2020. <https://ourworldindata.org/co2-and-other-greenhouse-gas-emissions>, (Accessed 08-20-2021).
- [104] Gerald F. Ross. Barbi - a new microwave precollision sensor for airbag activation in automobiles. In *1974 4th European Microwave Conference*, pages 146–149, 1974.

- [105] Tamas Ruppert and János Abonyi. Software sensor for activity-time monitoring and fault detection in production lines. *Sensors*, 2018, 2018.
- [106] Ashraf Saleem and Bashar Taha. Hybrid pso-hil approach for controller tuning in servo pneumatic systems. 2014.
- [107] Schleuniger. Schleuniger web page. <https://www.schleuniger.com/en/>.
- [108] P.W.B. Semmens and A.J. Goldfinch. *How Steam Locomotives Really Work*. 2000. Oxford University Press.
- [109] Marcin Serwinski. Follow-the-sun is it really a strategy from the perspective of strategic management? *Prace Naukowe Uniwersytetu Ekonomicznego we Wrocławiu*, 65:138–149, 2021.
- [110] Yabin Shen, Hongjin Xue, Shaohua Wang, Zhaomin Wang, Dongyu Zhang, Dongming Yin, Limin Wang, and Yong Cheng. A highly promising high-nickel low-cobalt lithium layered oxide cathode material for high-performance lithium-ion batteries. *Journal of Colloid and Interface Science*, 597:334–344, 2021.
- [111] Ulam S.M. On some statistical properties of dynamical systems. pages 315–320. 1961. UNIVERSITY OF CALIFORNIA.
- [112] K. K. Soo, Y. M. Siu, W. S. Chan, L. Yang, and R. S. Chen. Particle-swarm-optimization-based multiuser detector for cdma communications. *IEEE Transactions on Vehicular Technology*, 56(5):3006–3013, 2007.
- [113] D. Sparks, T. Noll, D. Agrotis, T. Betzner, and K. Gschwend. Multi-sensor modules with data bus communication capability. In *International Congress Exposition*, mar 1999. SAE International.
- [114] Andreas Spiess. How good are the ADCs inside Arduinos, ESP8266, and ESP32? And external ADCs (ADS1115). Technical report, Andreas, 2020. <https://www.youtube.com/watch?v=UAJMLTzrM9Q>, (Accessed 02-3-2020).
- [115] John Sprovieri. Handling high-mix harness assembly. 2016. <https://www.assemblymag.com/articles/93476-handling-high-mix-harness-assembly>.
- [116] Piotr Stefaniak. 31 COMPANIES AND 31 DIFFERENT MODELS. HERE'S HOW WE DEAL WITH CO2 (in Polish. 31 FIRM I 31 RÓŻNYCH MODELI. OTO, JAK RADZIMY

- SOBIE Z CO₂). 2021. <https://www.eecpoland.eu/2020/pl/wiadomosci/31-firm-i-31-roznych-modeli-oto-jak-radzimy-sobie-z-co2,455998.html>, (Accessed 08-2-2021).
- [117] Stanisław Stopiński, Krzysztof Anders, Sławomir Szostak, and Ryszard Piramidowicz. Optical time domain reflectometer based on application specific photonic integrated circuit. In *2019 Conference on Lasers and Electro-Optics Europe European Quantum Electronics Conference (CLEO/Europe-EQEC)*, pages 1–1, 2019.
- [118] Marius Strobl, Thomas Waas, Stefan Moehne, Markus Kucera, Andreas Rath, Norbert Balbierer, and Angelika Schingale. Using ethernet over powerline communication in automotive networks. In *Proceedings of the 10th International Workshop on Intelligent Solutions in Embedded Systems*, pages 39–44, 2012.
- [119] Marek Sznura and Piotr Przystałka. Development of a Power and Communication Bus Using HIL and Computational Intelligence. *Applied Sciences*, 11(18), 2021.
- [120] M. Taghavifard, Mojtaba Heydar, and Sed Mousavi. A genetic algorithm for scheduling flexible manufacturing cells. *Journal of Applied Sciences*, 9, 2009.
- [121] Mirosław Targosz. *Optimisation of the total energy consumption of an electric vehicle (in Polish. Optymalizacja energochłonności całkowitej pojazdu elektrycznego)*. PhD thesis, 2014.
- [122] N Terada, T Yanagi, S Arai, M Yoshikawa, K Ohta, N Nakajima, A Yanai, and N Arai. Development of lithium batteries for energy storage and ev applications. *Journal of Power Sources*, 100(1):80–92, 2001. *Journal of Power Sources Volume 100*.
- [123] Toyota. Toyota’s ‘mild hybrid’ system boosts fuel efficiency 15 Technical report, audi-Toyota-portal, 2001.
- [124] Ioan Cristian Trelea. The particle swarm optimization algorithm: convergence analysis and parameter selection. *Information Processing Letters*, 85(6):317–325, 2003.
- [125] Jerome Trommnau, Jens Kühnle, Jörg Siegert, Robert Inderka, and Thomas Bauernhansl. Overview of the state of the art in the production process of automotive wire harnesses, current research and future trends. *Procedia CIRP*, 81:387–392, 2019. 52nd CIRP Conference on Manufacturing Systems (CMS), Ljubljana, Slovenia, June 12-14, 2019.

- [126] P. Tsai, Chet Lo, You Chung Chung, and C. Furse. Mixed-signal reflectometer for location of faults on aging wiring. *IEEE Sensors Journal*, 5(6):1479–1482, 2005.
- [127] VDA. The commercial vehicle. Technical report, VDA.
- [128] E.H. Wakefield. *History of the Electric Automobile: Hybrid Electric Vehicles*. R.: Society of Automotive Engineers. 1998. Society of Automotive Engineers.
- [129] Hui Wang, Kai Xie, Lingyan Wang, and Yu Han. N-methyl-2-pyrrolidone as a solvent for the non-aqueous electrolyte of rechargeable li-air batteries. *Journal of Power Sources*, 219:263–271, 2012.
- [130] S.Y. Wang and K. Tai. Structural topology design optimization using genetic algorithms with a bit-array representation. *Computer Methods in Applied Mechanics and Engineering*, 194(36):3749–3770, 2005.
- [131] K.D. Wilkie, Martin Foster, D.A. Stone, and Chris Bingham. Hardware-in-the-loop tuning of a feedback controller for a buck converter using a ga. pages 680 – 684, 07 2008.
- [132] Wolf-produktionssysteme. Wolf-production systems laser processing (in german: Wolf-produktionssysteme laserbearbeitung). <https://www.wolf-produktionssysteme.de/laserbearbeitung>, (Accessed 06-20-2021).
- [133] Nils-Gerrit Wunsch. Largest autonomous driving patent owners worldwide from 2010 to 2019, by number of active patent families. <https://www.statista.com/statistics/1016110/worldwide-autonomous-driving-patent-owners-trend/>, (Accessed 08-20-2021).
- [134] Ewelina Włodarczyk. Education in the field of road safety in poland (in polish. edukacja w zakresie bezpieczeństwa ruchu drogowego w polsce). 02 2018.
- [135] Yamar. Technical report, Yamar. <https://yamar.com/>, (Accessed 03-20-2018).
- [136] A. Young. *Lunar and Planetary Rovers: The Wheels of Apollo and the Quest for Mars*. Springer Praxis Books. 2007. Springer New York.
- [137] Michalewicz Z. Genetic algorithms + data structures = evolutionary programs (in Polish. Algorytmy genetyczne + struktury danych = programy ewolucyjne). 1999. Wydawnictwo Naukowo-Techniczne.

- [138] Cong Zhang, Jeffery B. Greenblatt, Max Wei, Josh Eichman, Samveg Saxena, Matteo Muratori, and Omar J. Guerra. Flexible grid-based electrolysis hydrogen production for fuel cell vehicles reduces costs and greenhouse gas emissions. *Applied Energy*, 278:115651, 2020.
- [139] Ying Zhao and Junli Zheng. Particle swarm optimization algorithm in signal detection and blind extraction. In *7th International Symposium on Parallel Architectures, Algorithms and Networks, 2004. Proceedings.*, pages 37–41, 2004.
- [140] Zvei. Voltage classes for electric mobility 2013. Technical report.

Development of a Power and Communication Bus Using HIL and Computational Intelligence Techniques

Doctoral thesis - Summary

Author: M.Sc. Eng. Marek Sznura

Dissertation advisor: Ph.D. D.Sc. Eng. Piotr Przystałka, Associate Professor

Industry supervisor: Ph.D. Eng. Wojciech Sebzda

The main objective of this dissertation is to develop a power and communication bus using Hardware-in-the-Loop (HIL) and computational intelligence techniques. As a result of the research and development work carried out by the author, a Device Lightweight Network (DLN) bus has been proposed, which allows the transmission of data and power using two wires. The developed solution is dedicated mainly to the automotive industry, making it possible to supply power to selected executive and sensory systems of a vehicle while ensuring their communication with the embedded control systems. The dissertation addresses many issues in the field of mechanical engineering, including the construction and operation of modern automotive vehicles. The author focused his attention on various aspects concerning the design of conventional vehicle and battery electric vehicle, including the issue of CO₂ emission reduction. As a result of the literature survey and the analyses conducted, the author justified the need to innovate the cable harness by designing and developing a wholly new power and communication bus. The author has presented analyses confirming that the use of the proposed DLN bus can allow, among other things, a reduction in the weight of a motor vehicle and thus a reduction in CO₂ emissions, both by reducing the materials used in production and the energy consumption during operation. The development of a new power and communication bus was initially an engineering problem. However, the classical approach to DLN bus prototyping failed to develop a method for auto-addressing the modules operating in the network. For this reason, the main research objective of the dissertation was to elaborate a new prototyping method based on the HIL technique supported by computational intelligence algorithms to search for the optimal structure of communication modules, as well as the optimal characteristics of the hardware and software parts of these modules. As it is mentioned above, the desired properties of communication modules, which have a strong influence on the performance of the bus, cannot be found using a classical engineering approach due to the large number of possible combinations of configuration of the hardware and software parts of the whole system. Therefore, an HIL-based optimization method for bus prototyping is proposed, in which the optimization task is formulated

as a multi-criteria optimization problem. Several criterion functions are proposed, corresponding to the automotive objectives and requirements. Different soft computing optimization algorithms, such as a single-objective/multi-objectives evolutionary algorithm and a particle swarm optimization algorithm, are applied to searching for the optimal solution. The verification study was carried out in order to show the merits and limitations of the proposed approach. Attention was also paid to the problem of the selection of the behavioural parameters of the heuristic algorithms. The overall results proved the high practical potential of the DLN, which was developed using the proposed optimization method.

The dissertation resulted in the development of an innovative power and communication bus, which has a high practical and implementation potential from the perspective of DRÄXLMAIER's business. In addition, the author has developed an original method for the prototyping of mechatronic automotive systems based on the HIL technique supported by algorithms of computational intelligence, which has been implemented in the DRÄXLMAIER business and can now be successfully used for the development of new products of the company.

Opracowanie magistrali zasilająco-komunikacyjnej z wykorzystaniem technik HIL i inteligencji obliczeniowej

Praca doktorska - Streszczenie

Autor: Mgr inż. Marek Sznura

Promotor: Dr hab. inż. Piotr Przyszałka, prof. PŚ

Promotor wdrożeniowy: Dr inż. Wojciech Sebzda

Głównym celem pracy doktorskiej jest opracowanie magistrali zasilająco-komunikacyjnej z wykorzystaniem technik HIL (ang. Hardware-in-the-Loop) i inteligencji obliczeniowej. W wyniku prac badawczych i rozwojowych przeprowadzonych przez autora została zaproponowana magistrala DLN (ang. Device Lightweight Network) pozwalająca na przesyłanie danych oraz zasilanie z wykorzystaniem dwóch przewodów. Opracowane rozwiązanie jest dedykowane głównie do przemysłu samochodowego, umożliwiając zasilanie wybranych układów wykonawczych oraz sensorycznych pojazdu jednocześnie zapewniając ich komunikację z wbudowanymi układami sterowania. Praca doktorska porusza wiele zagadnień z zakresu inżynierii mechanicznej, w tym budowy i eksploatacji nowoczesnych pojazdów samochodowych. Autor skoncentrował uwagę na różnych aspektach dotyczących projektowania samochodów konwencjonalnych (ang. conventional vehicle) i elektrycznych (ang. battery electric vehicle) z uwzględnieniem zagadnienia redukcji emisji CO₂. W wyniku badań literaturowych i przeprowadzonych analiz uzasadnił konieczność wprowadzenia innowacji w zakresie wiązki kablowej poprzez zaprojektowanie i rozwój zupełnie nowej magistrali zasilająco-komunikacyjnej. Autor przedstawił analizy potwierdzające, że zastosowanie zaproponowanej magistrali DLN może pozwolić m.in. na zmniejszenie masy pojazdu samochodowego a co za tym idzie zmniejszenie emisji CO₂ zarówno poprzez redukcję wykorzystanych materiałów do produkcji, jak i zużycia energii podczas eksploatacji. Opracowanie nowej magistrali zasilająco-komunikacyjnej początkowo stanowiło typowy problem inżynierski. Podejście klasyczne do prototypowania magistrali DLN nie sprawdziło się jednak w zakresie opracowania metody auto-adresowania modułów pracujących w sieci. Z tego powodu głównym celem badawczym pracy doktorskiej było opracowanie nowej metody prototypowania opartej na technice HIL wspomaganej algorytmami inteligencji obliczeniowej w celu poszukiwania optymalnej struktury modułów komunikacyjnych, a także optymalnych cech części sprzętowych i programistycznych tych modułów. Jak wspomniano powyżej, pożądane właściwości modułów komunikacyjnych, które mają silny wpływ na

wydajność magistrali, nie mogą być znalezione przy użyciu klasycznego podejścia inżynierskiego ze względu na dużą liczbę możliwych kombinacji konfiguracji części sprzętowych i programowych całego systemu. Dlatego też zaproponowano metodę optymalizacji prototypowania magistrali opartą na metodzie HIL, w której zadanie optymalizacji sformułowano jako wielokryterialny problem optymalizacyjny. Zaproponowano kilka funkcji kryterialnych, odpowiadających celom i wymaganiom motoryzacyjnym. Do poszukiwania optymalnego rozwiązania zastosowano różne algorytmy optymalizacyjne, takie jak algorytm ewolucyjny jedno- i wielokryterialny oraz algorytm optymalizacji rojem cząstek. Przeprowadzono badania weryfikacyjne w celu wykazania zalet i ograniczeń proponowanego podejścia. Zwrócono również uwagę na problem doboru parametrów behawioralnych algorytmów heurystycznych. Uzyskane wyniki potwierdziły duży potencjał praktyczny sieci DLN, która została opracowana z wykorzystaniem zaproponowanej metody optymalizacji.

W ramach pracy doktorskiej powstała innowacyjna magistrala zasilająco-komunikacyjna, która cechuje się dużym potencjałem praktycznym i wdrożeniowy z perspektywy działalności firmy DRÄXLMAIER. Dodatkowo autor opracował oryginalną metodę prototypowania mechatronicznych układów samochodowych bazującą na technice HIL wspomaganej algorytmami inteligencji obliczeniowej, która została wdrożona w działalności firmy DRÄXLMAIER i może być obecnie z powodzeniem stosowana do rozwoju nowych produktów tej firmy.